

# Heavy Duty Connectors

重载连接器





The image features a teal background with a large, white, stylized circular graphic that is partially open at the top and bottom. In the center of this graphic, the letters "UTL" are written in a bold, white, sans-serif font.

**UTL**



## 企业简介

尤提乐电气有限公司成立于1990年，是专业接线端子生产企业，是该行业里技术力量雄厚、成长迅速、极具规模化的企业。

公司一贯坚持“以人为本，以市场为导向”的经营理念，在产品标准方面，尤提乐潜心研究了IEC、UL、TUV、GB、CE、CCC、ROHS、REACH等国内外相关标准，并按照这些标准自行编制了更为严格的企业标准，从产品的开发、模具的设计、原材料的采购、金属零部件的制作、塑料配件的成型，到成品组装以及品质检测、包装发货等，每个环节均由专业的人员按照相应的标准层层把关，以生产适销对路、应用于全球范围内工业自动化领域的产品为己任，积极追随、引进、借鉴国际知名品牌产品的技术，科技创新，锐意进取。目前公司生产的数十个系列，上千个规格的产品，为客户选型提供了丰富的产品保障。公司通过了德国莱茵TUV ISO9001质量管理体系及ISO14001环境体系认证，绝大部分产品通过了UL、CUL、TUV、CCC、CE认证，部分产品通过了VDE认证，所有产品均符合Rohs环保要求。

产品主要销往法国、俄罗斯、巴西、东南亚、港台等地区，作为一家以外销为主（出口65%）的民营独资企业，尤提乐置身于国际市场，直接感受市场气息，当面倾听客户需求，不断提升产品设计、生产、经营、管理过程中的技术含量，对生产作业的全过程实施科学的管理。近年来“尤提乐”名声遍及大江南北，“尤提乐”的经营理念发挥得淋漓尽致、深得人心，“尤提乐”的服务赢得广大客户赞赏。“腾飞的尤提乐，骄傲的尤提乐人”，尤提乐人正是凭借先进的管理模式、雄厚的技术实力、完善的工艺制程、一流的检测设备和精湛的模具加工技术，以生产高出性价比的产品为前提，凭借卓越的销售团队、周密的销售网络、专业化的服务，赢得了开拓市场新篇章的今天。



# Introduction

---

Utility Electrical Co., Ltd is a professional manufacturer of all kinds of wire connection terminal blocks was founded in 1990. UTL has grown into a leading manufacturer with strong R&D strength;rapid growth and large scale in this field.

The company has consistently adhered to the "people-oriented, market-oriented" business philosophy, product standards, UTILITY painstaking research of the IEC, UL, TUV, GB, CE, CCC, RoHS, REACH and other international and domestic standards for terminals, and in accordance with these standards preparing their own more stringent corporate standards, from the development, mold design, raw material procurement, production, plastic parts molding products, metal parts, to finished product assembly and quality testing, packaging, shipping, etc., each link are 'Checking at all levels' accordance with the appropriate standards by the professional staff to produce marketable, used worldwide industrial automation products as their responsibility to actively follow the introduction, learn technology, science and technology innovation internationally famous brand products, forge ahead.The company produced dozens of series, thousands of specifications of products for our customers to provide a rich selection of product protection. UTL has passed TUV Rheinland ISO9001 quality management system certification, the vast majority of products through the UL, CSA, CCC, CCS, CE certification, some products through the VDE certification, all products comply with Ro environmental requirements.

With the spirit of 'Pursuing Excellence, Innovating for Quality'.UTL always keeps the promise'All best srvice for all customers'.UTL warmly welcome domestic and foreign customers to cooperate with us to make prosperous future.



## 匠心尤存 至臻致远

高品质是赢得市场的保证，而有效的现代化管理和质量体系是支撑高品质的前提。在产品标准方面，尤提乐潜心研究了IEC、UL、CSA、GB、CE、CCC等国际国内关于接线端子的标准，并按照这些标准自行编制了更为严格的企业标准，从产品的开发、模具的设计、原材料的采购、金属零部件的制作、塑料配件的成型，到成品组装以及品质检测、包装发货等，每个环节均由专业的人员按照相应的标准层层把关，以生产适销对路、应用于全球范围内工业自动化领域的产品为己任，积极追随、引进、借鉴国际知名品牌的技术，科技创新，锐意进取。目前公司生产的数十个系列，上千个规格的产品，为客户选型提供了丰富的产品保障。

High quality is the guarantee of winning the market, while effective modern management and quality system is the premise to support high quality. In terms of product standards, especially Tiele has studied IEC, UL, CSA, GB, CE, CCC with great concentration and other international and domestic standards for wiring terminals, and according to these standards, The company has compiled stricter corporate standards, from product development, mold design, procurement of raw materials, production of metal parts, plastic parts. From the forming of parts, to the assembly of finished products, quality inspection, packaging and delivery, etc. Each link is checked by professional personnel according to the corresponding standards. To produce marketable products, used in the field of industrial automation worldwide products as their own responsibility, actively follow, introduce and learn from internationally renowned brand technology, technological innovation, and forge ahead. The company currently produces dozens of A series of products with thousands of specifications, providing a wealth of choices for customers product guarantee.

# 目录

## Content

### 芯子部分 Inserts

UTL-HA 系列 /HA Insert series	012
UTL-HE 系列 /HE Insert series	018
UTL-HEE 系列 /HEE Insert series	026
UTL-HD 系列 /HD Insert series	037
UTL-HDD 系列 /HDD Insert series	049
UTL-HSB 系列 /HSB Insert series	058
UTL-HK 系列 /HK Insert series	062
UTL-HE AV 系列 /HEAV Insert series	083
UTL-HM 系列 /HM Insert series	089
UTL-HQ 系列 /HQ Insert series	116

### 外壳部分 Hoods and housings

3A 外壳 /Size 3A Hoods/Housings	133
10A 外壳 /Size 10A Hoods/Housings	146
16A 外壳 /Size 16A Hoods/Housings	148
32A 外壳 /Size 32A Hoods/Housings	150
6B 外壳 /Size 6B Hoods/Housings	152
10B 外壳 /Size 10B Hoods/Housings	162
16B 外壳 /Size 16B Hoods/Housings	181
24B 外壳 /Size 24B Hoods/Housings	202
32B 外壳 /Size 32B Hoods/Housings	224
48B 外壳 /Size 48B Hoods/Housings	230
UTL-HC 外壳 HC Hoods/Housings	232

### 冷压针部分 Crimp contacts

5A 10A 16A 40A 70A 100A 200A	240
------------------------------	-----

### 附件 Accessories

编码 Coding pins	244
附件 / 框架 Accessories/ frame	246
工具 Removal Tool	247
电缆接头 Cable glands	249



# Field of Application

## 应用领域

尤提乐连接器丰富的产品系列，能够满足不同领域、不同场合的电气或者信号的连接要求，保证各组件在各种环境中的安全、可靠、高效的协同运行。

UTL Heavy duty connectors with rich product series, are used wherever there is a need for a secure, simple and time-saving assembly of machinery and facilities.

We skilled in the fields of energy and data transmission are able to contribute a great deal more and play a closely integrati role in the value creation process!

Our claim: The relentless pursuit of perfection!





# Ingress Protection

## 外壳防护等级

连接器上的外壳，密封件及锁扣装置使连接器的电气部件免受影响，比如冲击、异物、湿气、灰尘、水或清洁剂、冷却液、油等其它液体入侵。

The connector's housing, sealing and locking mechanism protect the connection from external influences such as mechanic shocks, foreign bodies, humidity, dust, water or other fluids such as cleansing and cooling agents, oils, etc.

下面是防护等级一览表 The following table shows the different degrees of protection



数字 Numeral	保护范围 Degree of protection	数字 Numeral	保护范围 Degree of protection
0	无防护 Not evaluated	0	无防护 Not evaluated
1	防止直径大于50mm的固体外物侵入 ≥50.0mm diameter object	1	防止水滴侵入 Dripping water:vertical
2	防止直径大于12.5mm的固体外物侵入 ≥12.5mm diameter object	2	倾斜15度时，仍可防止水滴侵入 Dripping water:15° tilt
3	防止大于直径2.5mm的固体外物侵入 ≥2.5mm diameter object	3	防止喷洒的水侵入 /Spraying water
4	防止大于直径1.0mm的固体外物侵入 ≥1.0mm diameter object	4	防止飞溅的水侵入 Splashing water
5	防止外物及灰尘 Dust-protected	5	防止喷射的水侵入 Jetting water
6	防止外物及灰尘 Dust-tight	6	防止大浪侵入 Powerful jetting water
		7	防止浸水时水的侵入 Temporary immersion
		8	防止沉没时水的侵入 Continuous immersion



# Main Components

## 主要部件

### 接插件安装示意图 Assembly details

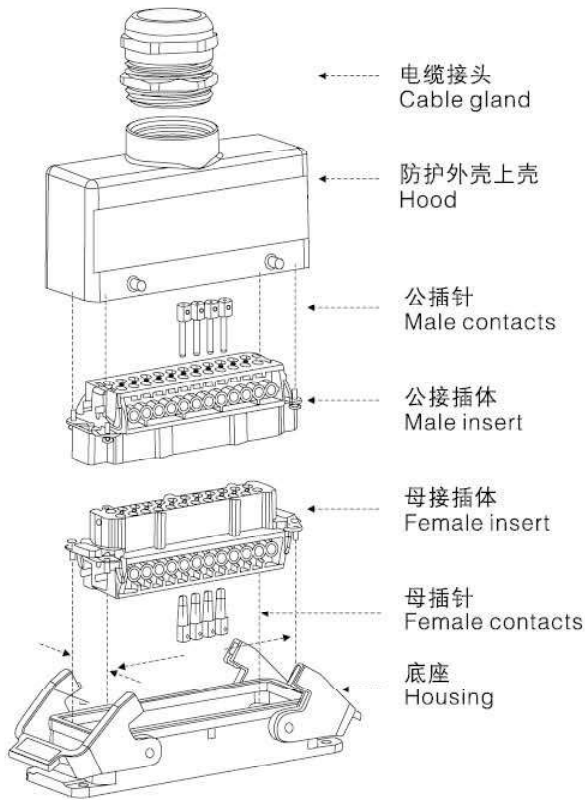

### 电缆接头 Cable glands

金属或塑料电缆接头 Metal or plastic cable glands

金属或塑料软管接头 Metal or plastic hose glands

其它电缆接头 Other cable glands

### 防护外壳上壳 Hoods

标准或高结构 Low or high construction

顶部出线或侧面出线 Top or side cable entry

单扣或双扣 1 or 2 locking levers

### 公、母接插体 Male, female insert

螺丝连接 Screw terminal

冷压连接 Crimp terminal

弹片连接 Cage-clamp terminal

### 公、母插针 Male, female contacts

适用于冷压连接的插体 Only for crimp terminal

镀金或镀银 Gold or silver plated

### 底座 Housing

开孔安装, 表面安装或电缆对接

Bulkhead mounting, surface mounting, cable to cable

标准或高结构 Low or high construction

单扣或双扣 1 or 2 levels

带塑料盖或带金属盖或不带盖 Housing with or without cover

### 订货号说明/Part number explanation











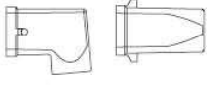

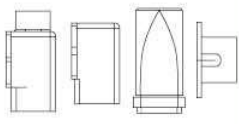



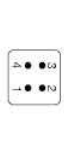
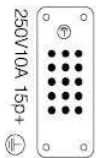



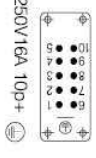
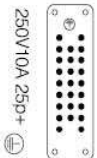









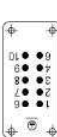



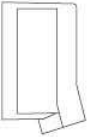
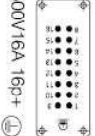
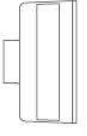

i.e.: 09330242601

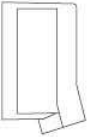
09 33 024 2601

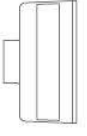

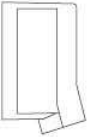
# Part of the products

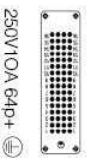
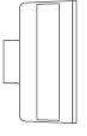
## 部分产品一览表

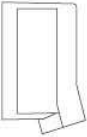
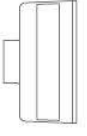
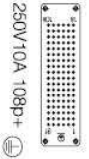
上壳 Hoods	插体 Inserts	UTL-HA Series Screw terminal Crimp terminal	UTL-HE Series Screw terminal Spring terminal Crimp terminal	*UTL-HEE Series Crimp terminal	*UTL-HD Series Crimp terminal	*UTL-HDD Series Crimp terminal	UTL-HSB Series Screw terminal	UTL-HK Series Screw terminal	下壳 Housings	
3A										
		230/400V/10A 3p+ 			250V/10A 7p+ 					
10A										
		230/400V/10A 4p+ 			250V/10A 15p+ 					
16A										
		250V/16A 10p+ 			250V/10A 25p+ 					
32A		用于安装在两个适用于16A外壳插体 Suitable for 2 inserts of size 16A								
										
6B										
		500V/16A 6p+ 								
10B										
		500V/16A 10p+ 								
16B										
		500V/16A 16p+ 								
24B										
		500V/16A 24p+ 			250V/10A 40p+ 					
32B										
		500V/16A 46p+ 			250V/10A 64p+ 					
48B		用于安装在两个适用于24B外壳插体 Suitable for 2 inserts of size 24B								
										

### 冷压连接插体的技术参数 Crimp terminal inserts information

线规 Wire gauge		内部直径 Diameter	剥线长度 Stripping length (mm)		
(mm <sup>2</sup> )	AWG	Φ (mm)	UTL-HDD UTL-HD R15模块 (10A)	UTL-HE UTL-HA UTL-HVE (16A)	UTL-HC (40A)
0.14-0.37	26-22	0.9	8	-	-
0.5	20	1.15	8	7.5	-
0.75	18	1.3	8	7.5	-
1	18	1.45	8	7.5	-
1.5	16	1.75	8	7.5	9
2.5	14	2.25	6	7.5	9
4	12	2.85	-	7.5	9.6
6	10	3.5	-	-	9.6
10	8	4.6	-	-	15

	导体截面 Cross-sec	Φ	剥线长度 Stripping length
100A针	10mm <sup>2</sup>	4.3mm	19.0mm
	16mm <sup>2</sup>	5.5mm	19.0mm
	25mm <sup>2</sup>	7.0mm	19.0mm
	35mm <sup>2</sup>	8.2mm	16.0mm
350A针	35mm <sup>2</sup>	8.2mm	26.0mm
	50mm <sup>2</sup>	10.0mm	28.0mm
	70mm <sup>2</sup>	11.5mm	28.0mm
	95mm <sup>2</sup>	13.5mm	30.0mm
650A针	120mm <sup>2</sup>	15.5mm	24.0mm
	240mm <sup>2</sup>	22.5mm	50.0mm
细股绞线依据 Wire assembly according to IEC60228-5			

### 其他说明 Additional info

建议使用的拧紧力矩和螺丝的尺寸 Recommended tightening torque and size of screw driver

螺丝规格 Screw size	接插件类型 Connector type	拧紧力矩 Tightening torque (N.m)	拧紧力矩 Tightening torque (lbf)	建议使用螺丝刀的尺寸 Recommended size of screw driver
M3	螺丝端子 Screw terminal UTL-HA-003/UTL-HA-004	0.25	0.2	0.4x2.5
M3	螺丝端子 Screw terminal UTL-HA-010/UTL-HA-016	0.5	0.4	0.5x3.5 or +Size1
M3	螺丝端子 UTL-HE, 定位及固定用 Screw terminal UTL-HE, Guiding pins and bushes	0.50	0.40	"0.5 x 3.5"
M4	接地螺钉端子 Ground terminal UTL-HA, UTL-HE, UTL-HD, UTL-HDD	1.2	0.9	0.5x3.5 or +Size1+2
M4	端子块 Screw terminal UTL-HSB	1.2	0.9	0.80 x 4.5
M5	接地螺钉端子 Ground terminal UTL-HSB	2.00	1.40	"0.8 x 4.5 or 1.2 x 8"

# Terminal Type

## 接线端子类型

### 螺钉压接形式 Screw terminal

UTL-HA系列 Haseries  
 UTL-HE/HVE 系列 HE/HVE series  
 UTL-HSB系列 HSB series  
 UTL-HK系列 HK series  
 UTL-HWK系列 HWK series  
 UTL-HEAV系列 HEAV series

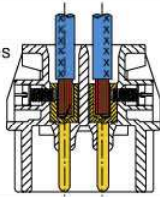

操作简单  
Easy handling

无需专用工具  
No special tools

接插芯 Inserts	最大线规 Max. wire gauge		剥线长度L(mm) Stripping length L(mm)
	mm <sup>2</sup>	AWG	
UTL-HA-003,HA-004	2.5	14	4.5
UTL-HE,HA,HEAV	2.5	14	7.5
UTL-HE,HVE	4.0	12	7.5
UTL-HSB	6.0	10	11.5
UTL-HK,HWK	16.0	5.0	14

### 冷压针压接形式 Crimp terminal

UTL-HD 系列 HD series  
 UTL-HDD 系列 HDD series

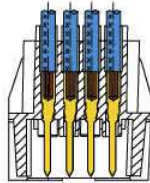

由于压接质量均匀, 所以通电阻恒定  
Constant contact resistance as a result of precisely repeated crimp connection quality

由于接近于冷焊, 所以保证了耐腐蚀性  
Corrosion free connections as a result of cold weld action

接插芯 Inserts	最大线规 Max. wire gauge		剥线长度L(mm) Stripping length L(mm)	
	mm <sup>2</sup>	AWG	UTL-HDD/HD	UTL-HEC/HAC
UTL-HD	0.5	20	8.0	7.5
	0.75	18	8.0	7.5
UTL-HDD	1.0	18	8.0	7.5
UTL-HM(10A)	1.5	16	8.0	7.5
	2.5	14	8.0	7.5
	4.0	12	8.0	7.5

UTL-HE/HEE 系列 Series  
 UTL-HEEE 系列 Series  
 UTL-HM 系列 series

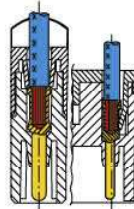

预置了带压接针的电缆束  
Pre-preparation of cable forms with crimp contacts fitted

从根本上提高了布线速度  
Optimum cost cable connection

接插芯 Inserts	最大线规 Max. wire gauge		剥线长度L(mm) Stripping length L(mm)
	mm <sup>2</sup>	AWG	
UTL-HE	0.5	20	7.5
	0.75	18	7.5
UTL-HEE	1.0	18	7.5
UTL-HEEE	1.5	16	7.5
UTL-HM	2.5	14	7.5
	4.0	12	7.5

### 弹片压接端子形式 Cage-clamp terminal

UTL-HE 系列 Series

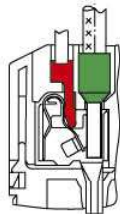

这种连接技术对操作和工具的要求较小, 且具有较高的功能安全性。  
This termination method requires very little preparation of the wire and on special tools, leading to a low installed cost and a high degree of mechanical security.

由于操作人员可以看到导线和螺丝刀, 因此具有较高的操作舒适度。  
Ease of termination. Conductor and screwdriver are in same plane.

接插芯 Inserts	最大线规 Max. wire gauge		剥线长度L(mm) Stripping length L(mm)
	mm <sup>2</sup>	AWG	
UTL-HE	0.14-2.5	26-14	9-11

无需对导线头进行特殊处理。  
No special preparation of stripped conductor.

夹紧力随导线截面的增加而提高。  
The larger the conductor the higher the clamping force.

安装状态下可从接线侧进行检测。  
From the terminal side for testing installation condition.

导线连接防振动和冲击。  
The termination is vibration-proof.

### 轴向螺栓压接形式 Axial screw terminal

UTL-HK-006/6  
 UTL-HK-006/12  
 UTL-HK-008/0

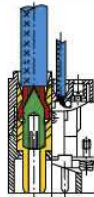

节省空间  
Less space required

操作简单  
Easy handling

无需专用工具  
No special tools

接插芯 Inserts	最大线规 Max. wire gauge		剥线长度L(mm) Stripping length L(mm)
	mm <sup>2</sup>	AWG	
UTL-HK-006/6	16-35	5-2	13-14
UTL-HK-006/12	2.5-10	13/-1	8-9
UTL-HK-008/0	10-25	16/-1	6-7

### 建议使用的拧紧力矩和螺丝刀的尺寸 Recommended screw drivers and tightening torques

螺钉尺寸 Size of screw	接插件类型 Connector type	拧紧力矩 (Φ) Tightening torque [Nm]	拧紧力矩 (Φ) Tightening torque [Nm]	建议使用螺丝刀尺寸 Recommended size of screw driver
M3	螺钉端子 Screw terminal HA-003/HA-004/HQ-005	0.25	0.20	0.4×2.5
M3	螺钉端子 Screw terminal HA-010/HA-016	0.50	0.40	0.5×3.5 or ±size 1
M3	螺钉端子 HE, HEAV 定位及固定用 Screw terminal HE, HEAV fixing screws of all kinds, guiding pins and bushes	0.50	0.40	0.5×3.5
M4	接地端子螺钉 Ground terminal HA, HE, HD, HDD	1.20	0.90	0.5×3.5 or ±size 1+2
M4	端子块 Terminal blocks HSB	1.20	0.90	0.8×4.5
M5	接地端子螺钉 Ground terminal HSB	2.00	1.40	0.8×4.5 or 1.2×8.0

# Selection Guide

## 选型指南

购买重型连接器时，我们可以做如下选择 When selecting heavy duty connector, we need to choose as following

NO.1



上壳侧出，底座开孔形式  
Hood side-entry type, Housing bulkhead mounting

NO.2



上壳顶出，底座开孔形式  
Hood top-entry type, Housing bulkhead mounting

NO.3



上壳侧出，底座表面形式  
Hood side-entry type, Housing surface mounting

NO.4



上壳顶出，底座表面形式  
Hood top-entry type, Housing surface mounting

NO.5



上壳侧出，底座开孔带盖形式  
Hood side-entry type, Housing bulkhead mounting cover

NO.6



上壳顶出，底座开孔带盖形式  
Hood top-entry type, Housing bulkhead mounting cover

NO.7



上壳侧出，底座表面带盖形式  
Hood side-entry type, Housing surface mounting cover

NO.8



上壳顶出，底座表面带盖形式  
Hood top-entry type, Housing surface mounting cover

NO.9



上壳顶出，下壳对接形式  
Hood top-entry type, Housing cable to cable coupling

### 订购完整连接器套件步骤：

For a complete connector components may be order from the following sub headings:

#### 1 接插体类别 Connector type

如：24芯螺钉压接接插体型号为 HE-024  
i.e.: 24-polescrew terminal part NO.HE-024

#### 2 壳体组合类别 List hoods and housings

常见九种组合方式见上图如：1是上壳侧出底座开孔形式  
i.e.: "1" Hood side-entry type, Housing bulkhead mounting

#### 3 螺丝毫米大小 Threaded hole size

如：“M25”代表出线口螺纹为公制M25  
i.e.: "M25" metric thread M25

例如：UTL-HK-HE-024.1-M25 代表接插体是HE-024，外壳是第一种组合（开孔侧出），上壳出线口螺纹为M25。

### 套件订货说明 Ordering system computerized

为了便于数据处理，订货时也可采用如下订货方式：

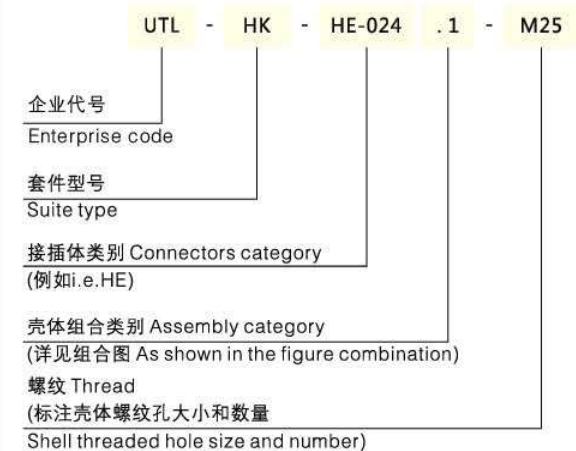

# Quick Lock Terminal

## 直插式重载连接器产品介绍

### 产品研发背景 Product development background

随着人工成本的持续升高，产品成本随之增加，导致工业设备厂家失去产品竞争力；而大部分工时的消耗发生在基础工艺工序；因此，有必要对基础元件的产品进行结构优化，提高工作效率。昊科直插式连接器颠覆传统接线工艺，在满足传统螺钉压接、笼式压接连接器，所有功能以外，在使用效率上有大幅提高。



产品推荐

### 功能描述 Function description

1 在开孔安装的情况下，直插式连接器可实现连接器预安装在柜体上，再接线，如图一



图 1



2 为不影响柜内接线的整洁及规范，柜内的线束长度一般会尽量缩短，螺钉安装的连接器的压接螺丝被壳体遮挡，需要把线预留的长一些拉到柜体外，先接到连接器上再固定外壳，这时柜内的线就会过长，影响布线工艺 如图二



图 2



其它压接方式 Other terminal

3 直插式接线方式可轻松的接线，当产品需增减某些线束时，直插式连接器也不需要拆装连接器壳体就可实现，如图三

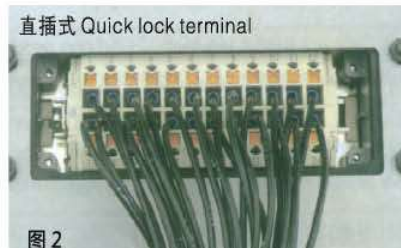

图 3

4 直插式连接器为用户预留的测试孔，可实现带电测试，如图四



图 4

5 直插式连接器运用编码块（图五）替代传统的编码销，实现多个连接器防插错，工艺简单、成本极低、将编码块压入插槽内即可实现（图六）

图 5

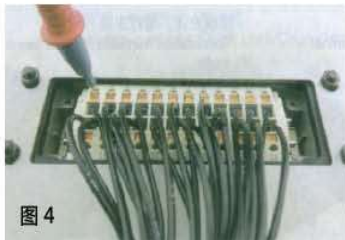

传统连接器运用编码销，需要先把固定螺丝取下，换上编码销，操作麻烦费时，且价格相比编码块高昂。

图 6

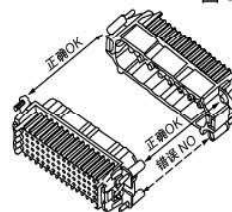

### 产品接线方式对比 Product wiring method

产品 Product	直插式 Quick lock terminal 24 inserts(公插M+母插F)	弹片压接 Cage-clamp terminal 24 inserts(公插M+母插F)	螺钉压接 Screw terminal 24 inserts(公插M+母插F)
接线耗时 Connection time	6分钟min	12.5分钟min	15分钟min

### 1 直插式弹片接线方式 Quick Lock terminal



Step 1:导线插入 Wire insertion



Step 2:接线完成 Connection completion

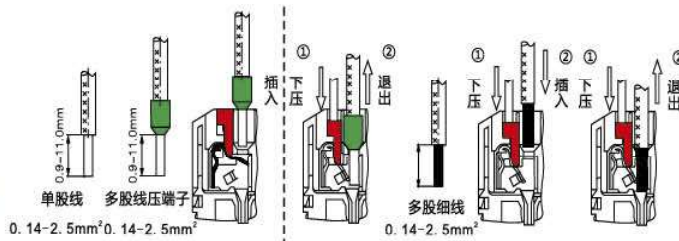

### 2 普通弹片接线方式 Cage-clamp terminal



Step 1 螺钉起子插入正方形插孔中，弹片被推向一侧，从而打开接线口。

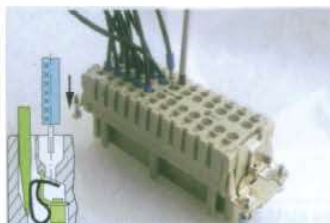

Step 2 将线缆插入圆形接口。

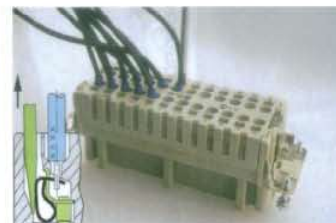

Step 3 取出螺丝起子，弹片收回原位，从而夹紧插入的线缆。

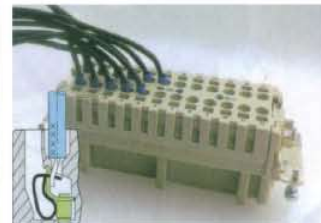

Step 4 连接完成，请拉动线缆以确认线缆确实被弹片夹紧。

### 3 螺钉接线方式 Screw terminal

手工拧紧或电动螺丝刀拧紧，拧紧力不一致，导致螺丝没拧到位，同时在振动条件下，螺丝有松脱可能。因为拧紧力度不一样，使用工具的不规范，容易导致十字螺丝头打滑，从而极大的增加了作业人员的劳动强度。

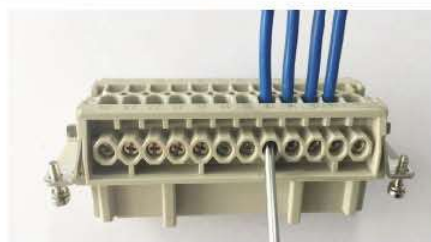
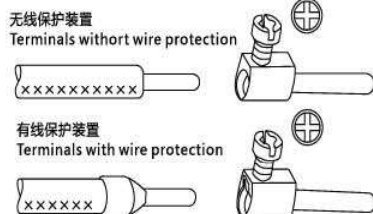



# UTL-HA 系列 / HA SERIES

小型标准连接器 / Compact Standard Connector



# Small core insert

## UTL-HA 系列小型插芯

### 技术参数 Technical Characteristics

规范	Specifications	
规范	Specifications	DIN EN 60 664
		DIN EN 61 984
插芯	Inserts	
接插件针数	Number Of Contacts	3,4,10,16,32(2X16)+PE
UTL-HA-003/004		
额定电流	Rated Current	10A
相对地额定电压	Rated Voltage Conductor-ground	230V
相间额定电压	Rated Voltage Conductor-conductor	400V
额定脉冲电压	Rated Impulse Voltage	4kV
污染程度	Pollution Degree	3
或	Or	10A 250V 4kV 3
UTL-HA-010/016		
额定电流	Rated Current	16A
额定电压	Rated Voltage	250V
额定脉冲电压	Rated Impulse Voltage	4kV
污染程度	Pollution Degree	3
污染等级2时的参数	Pollution Degree 2 Also	16A 230/400V 4kV 2
依据UL/CSA额定电压	Rated Voltage Acc.to UI Csa	600V
绝缘电阻	Insulation Resistance	$\geq 10^{10} \Omega$
材料	Material	聚碳酸酯 Polycarbonate
工作温度范围	Limiting Temperatures	-40°C...+125°C
阻燃等级	Flammability Acc. To UI94	V0
可接插次数	Mechanical Working Life-mating Cycles	$\geq 500$
插针	Contacts	
材料	Material	铜合金 Copper Alloy
表面处理	Surface	镀金 Hard-gold Plated 镀银 Hard-silver Plated
接触电阻	Contact Resistance	$\leq 1m\Omega$
螺钉连接	Screw Terminal	
导线规格	Wire Gauge	1.0-2.5mm <sup>2</sup>
AWG	Awg	18-14
拧紧力矩	Tightening Torque	0.25Nm ( HA-003/004 ) or 0.5Nm ( HA-010/016 )
冷压连接	Crimp Terminal	
导线规格	Wire Gauge	0.14-4.0mm <sup>2</sup>
AWG	Awg	26-12
弹片连接	Cage-clamp	
导线规格	Wire Gauge	0.14-2.5mm <sup>2</sup>
AWG	Awg	26-14

### 电流负载能力 Current Carrying Capacity

电流负载能力所受的限制主要来自包含接插针的接插体可承受的最大温度

The current carrying is limited by maximum temperature of materials for Inserts and contacts including terminals.

测试和控制过程依据 Measuring and testing techniques according to DIN EN 60512-5

①线径 Wire gauge: 2.5mm<sup>2</sup> ②线径 Wire gauge: 1.5mm<sup>2</sup> ③线径 Wire gauge: 1.0mm<sup>2</sup>

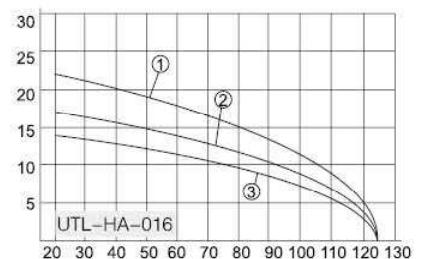
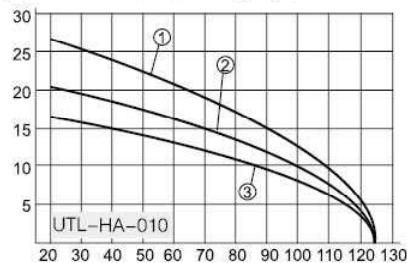
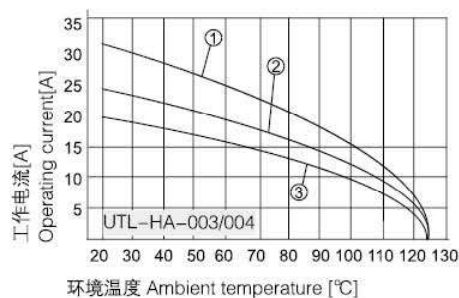

# Small core insert

## UTL-HA- 003/004 小型插芯 230/400V 10A3/4+ ⊕

### 插芯 Inserts

外壳尺寸：匹配3A外壳，详情请参考11-05-11-11页

Hoods/Housings: Matching 3A Hood Housing, detail on P11-05-P11-11

#### 螺丝连接 Screw terminal



插芯 Inserts	型号 Type	订货号 Part Number
公 Male	UTL-HA-003-M	09200032611
母 Female	UTL-HA-003-F	09200032711

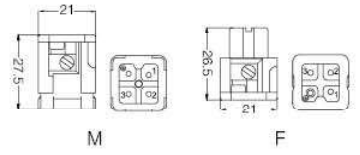

公 Male	HA-004-M	09200042611
母 Female	UTL-HA-004-F	09200042711

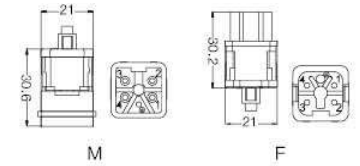

#### 弹片连接 Cage-clamp



插芯 Inserts	型号 Type	订货号 Part Number
公 Male	UTL-HA-003-MS	09200032633
母 Female	UTL-HA-003-FS	09200032733

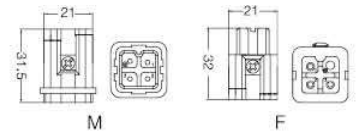

公 Male	UTL-HA-004-MS	09200042633
母 Female	UTL-HA-004-FS	09200042733

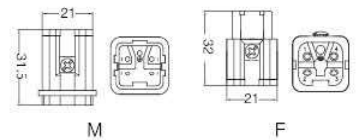

# Small core insert

## UTL-HA- 010 小型插芯 230/400V 16A 10+

### 插芯 Inserts

外壳尺寸：匹配10A外壳，详情请参考12-01~12-02页

Hoods/Housings: Matching 10A Hood Housing, detail on P12-01~P12-02

#### 螺丝连接 Screw terminal



插芯 Inserts	型号 Type	订货号 Part Number
公 Male	UTL-HA-010-M	09200102612
母 Female	UTL-HA-010-F	09200102812

#### 接插体之间的最大距离24mm

Distance for contact max.24mm

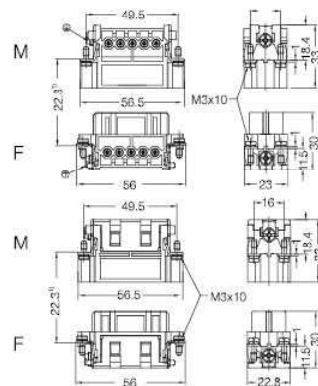

#### 接插针排序

Contacts arrangement view from termination side

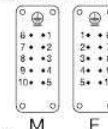

#### 面板安装开孔图

Panel cut out for Inserts for use without Hoods/housings

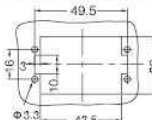

#### 冷压连接 Crimp terminal



插芯 Inserts	型号 Type	订货号 Part Number
公 Male	UTL-HA-010-MC	09200103001
母 Female	UTL-HA-010-FC	09200103101

### 附件 Accessories

#### 16A 冷压针 Crimp contacts

接触电阻 Contact resistance  $\leq 1m\Omega$

镀银 Silver plated



镀金 Gold plated



#### 工具 Tools

冷压钳 Crimping tool



退针器 Removal tool



公 Male	订货号 Part Number	母 Female	订货号 Part Number
CESM-0.37	09330006127	CESF-0.37	09330006227
CESM-0.5	09330006121	CESF-0.5	09330006220
CESM-0.75	09330006114	CESF-0.75	09330006214
CESM-1.0	09330006105	CESF-1.0	09330006205
CESM-1.5	09330006104	CESF-1.5	09330006204
CESM-2.5	09330006102	CESF-2.5	09330006202
CESM-3.0	09330006106	CESF-3.0	09330006206
CESM-4.0	09330006107	CESF-4.0	09330006207

公 Male	订货号 Part Number	母 Female	订货号 Part Number
CEGM-0.37	09330006117	CEGF-0.37	09330006217
CEGM-0.5	09330006122	CEGF-0.5	09330006222
CEGM-0.75	09330006115	CEGF-0.75	09330006215
CEGM-1.0	09330006118	CEGF-1.0	09330006218
CEGM-1.5	09330006116	CEGF-1.5	09330006216
CEGM-2.5	09330006123	CEGF-2.5	09330006223
CEGM-4.0	09330006119	CEGF-4.0	09330006221

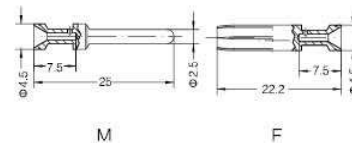

标示 Identification	线规 Wire gauge	剥线长度 Stripping length
no groove	0.14-0.37mm <sup>2</sup> AWG 26-22	7.5mm
no groove	0.5mm <sup>2</sup> AWG 20	7.5mm
1 groove	0.75mm <sup>2</sup> AWG 18	7.5mm
1 groove	1.0mm <sup>2</sup> AWG 18	7.5mm
2 groove	1.5mm <sup>2</sup> AWG 16	7.5mm
3 groove	2.5mm <sup>2</sup> AWG 14	7.5mm
wide groove	3mm <sup>2</sup> AWG 12	7.5mm
no groove	4mm <sup>2</sup> AWG 12	7.5mm

压接线经 Wire gauge	型号 Type	订货号 Part Number
0.5-4mm <sup>2</sup>	TL02G	09990000021

适用类型 For	型号 Type	订货号 Part Number
16A 冷压针	TL01	09990000059
16A Crimp contacts		

更多工具请参考 25-01~25-02页 More tools on P25-01~P25-02

# Small core insert

## UTL-HA- 016 小型插芯 250V 16A+⊕

### 插芯 Inserts

外壳尺寸: 匹配16A外壳, 详情请参考13-01~13-02页

Hoods/Housings: Matching 16A Hood Housing, detail on P13-01~P13-02

#### 螺丝连接 Screw terminal



插芯 Inserts	型号 Type	订货号 Part Number
公 Male	UTL-HA-016-M	09200162612
母 Female	UTL-HA-016-F	09200162812

接插体之间的最大距离24mm  
Distance for contact max.24mm

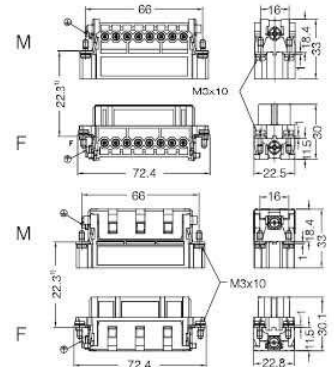

#### 冷压连接 Crimp terminal



插芯 Inserts	型号 Type	订货号 Part Number
公 Male	UTL-HA-016-MC	09200163001
母 Female	UTL-HA-016-FC	09200163101

#### 接插针排序

Contacts arrangement view from termination side

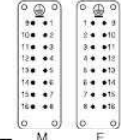

#### 面板安装开孔图

Panel cut out for Inserts for use without Hoods/housings

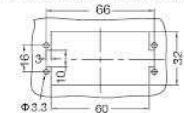

### 附件 Accessories

#### 16A 冷压针 Crimp contacts

接触电阻 Contact resistance  $\leq 1m\Omega$   
镀银 Silver plated



公 Male	订货号 Part Number	母 Female	订货号 Part Number
CESM-0.37	09330006127	CESF-0.37	09330006227
CESM-0.5	09330006121	CESF-0.5	09330006220
CESM-0.75	09330006114	CESF-0.75	09330006214
CESM-1.0	09330006105	CESF-1.0	09330006205
CESM-1.5	09330006104	CESF-1.5	09330006204
CESM-2.5	09330006102	CESF-2.5	09330006202
CESM-3.0	09330006106	CESF-3.0	09330006206
CESM-4.0	09330006107	CESF-4.0	09330006207

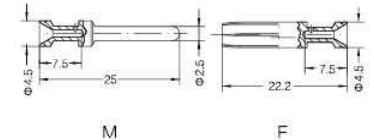

#### 镀金 Gold plated



公 Male	订货号 Part Number	母 Female	订货号 Part Number
CEGM-0.37	09330006117	CEGF-0.37	09330006217
CEGM-0.5	09330006122	CEGF-0.5	09330006222
CEGM-0.75	09330006115	CEGF-0.75	09330006215
CEGM-1.0	09330006118	CEGF-1.0	09330006218
CEGM-1.5	09330006116	CEGF-1.5	09330006216
CEGM-2.5	09330006123	CEGF-2.5	09330006223
CEGM-4.0	09330006119	CEGF-4.0	09330006221

标示 Identification	线规 Wire gauge	剥线长度 Stripping length	
no groove	0.14~0.37mm <sup>2</sup>	AWG 26-22	7.5mm
no groove	0.5mm <sup>2</sup>	AWG 20	7.5mm
1 groove	0.75mm <sup>2</sup>	AWG 18	7.5mm
1 groove	1mm <sup>2</sup>	AWG 18	7.5mm
2 groove	1.5mm <sup>2</sup>	AWG 16	7.5mm
3 groove	2.5mm <sup>2</sup>	AWG 14	7.5mm
wide groove	3mm <sup>2</sup>	AWG 12	7.5mm
no groove	4mm <sup>2</sup>	AWG 12	7.5mm

#### 工具 Tools

##### 冷压钳 Crimping tool



##### 退针器 Removal tool



压接线经 Wire gauge	型号 Type	订货号 Part Number
0.5~4mm <sup>2</sup>	TL02G	09990000021

适用类型 For	型号 Type	订货号 Part Number
16A 冷压针	TL01	09990000059
16A Crimp contacts		

更多工具请参考 25-01~25-02页. More tools on P25-01~P25-02

# Small core insert

## UTL-HA-032 小型插芯 250V 16A 32+⊕

### 插芯 Inserts

外壳尺寸: 匹配32A外壳, 详情请参考14-01~14-02页

Hoods/Housings: Matching 32A Hood Housing, detail on P14-01~P14-02

#### 螺丝连接 Screw terminal



插芯 Inserts	型号 Type	订货号 Part Number
公 Male	UTL-HA-016-M(1-16)	09200162612
	UTL-HA-016-M(17-32)	09200162613
母 Female	UTL-HA-016-F(1-16)	09200162812
	UTL-HA-016-F(17-32)	09200162813

接插体之间的最大距离24mm

Distance for contact max.24mm

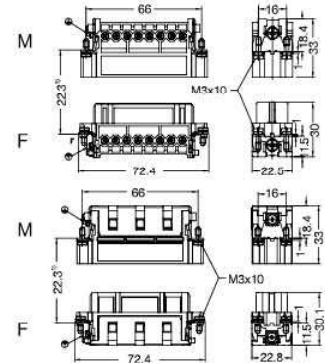

#### 接插针排序

Contacts arrangement view from termination side

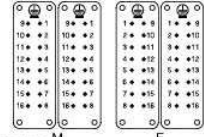

#### 面板安装开孔图

Panel cut out for Inserts for use without Hoods/housings

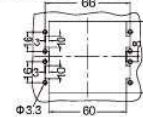

#### 冷压连接 Crimp terminal



插芯 Inserts	型号 Type	订货号 Part Number
公 Male	UTL-HA-016-MC(1-16)	09200163001
	UTL-HA-016-MC(17-32)	09200163011
母 Female	UTL-HA-016-FC(1-16)	09200163101
	UTL-HA-016-FC(17-32)	09200163111

### 附件 Accessories

#### 16A 冷压针 Crimp contacts

接触电阻 Contact resistance  $\leq 1m\Omega$   
镀银 Silver plated



#### 镀金 Gold plated



#### 工具 Tools

##### 冷压钳 Crimping tool



##### 退针器 Removal tool



公 Male	订货号 Part Number	母 Female	订货号 Part Number
CESM-0.37	09330006127	CESF-0.37	09330006227
CESM-0.5	09330006121	CESF-0.5	09330006220
CESM-0.75	09330006114	CESF-0.75	09330006214
CESM-1.0	09330006105	CESF-1.0	09330006205
CESM-1.5	09330006104	CESF-1.5	09330006204
CESM-2.5	09330006102	CESF-2.5	09330006202
CESM-3.0	09330006106	CESF-3.0	09330006206
CESM-4.0	09330006107	CESF-4.0	09330006207

CEGM-0.37	09330006117	CEGF-0.37	09330006217
CEGM-0.5	09330006122	CEGF-0.5	09330006222
CEGM-0.75	09330006115	CEGF-0.75	09330006215
CEGM-1.0	09330006118	CEGF-1.0	09330006218
CEGM-1.5	09330006116	CEGF-1.5	09330006216
CEGM-2.5	09330006123	CEGF-2.5	09330006223
CEGM-4.0	09330006119	CEGF-4.0	09330006221

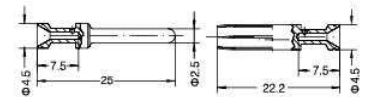

标示 Identification	线规 Wire gauge	剥线长度 Stripping length	
no groove	0.14-0.37mm <sup>2</sup>	AWG 26-22	7.5mm
no groove	0.5mm <sup>2</sup>	AWG 20	7.5mm
1 groove	0.75mm <sup>2</sup>	AWG 18	7.5mm
1 groove	1.0mm <sup>2</sup>	AWG 18	7.5mm
2 groove	1.5mm <sup>2</sup>	AWG 16	7.5mm
3 groove	2.5mm <sup>2</sup>	AWG 14	7.5mm
wide groove	3mm <sup>2</sup>	AWG 12	7.5mm
no groove	4mm <sup>2</sup>	AWG 12	7.5mm

压接线经 Wire gauge	型号 Type	订货号 Part Number
0.5-4mm <sup>2</sup>	TL02G	09990000021

适用类型 For	型号 Type	订货号 Part Number
16A 冷压针	TL01	09990000059
16A Crimp contacts		

更多工具请参考 25-01~25-02页 More tools on P25-01~P25-02

# UTL-HE 系列 / HE SERIES

最常规的标准连接器 | Standard Connector

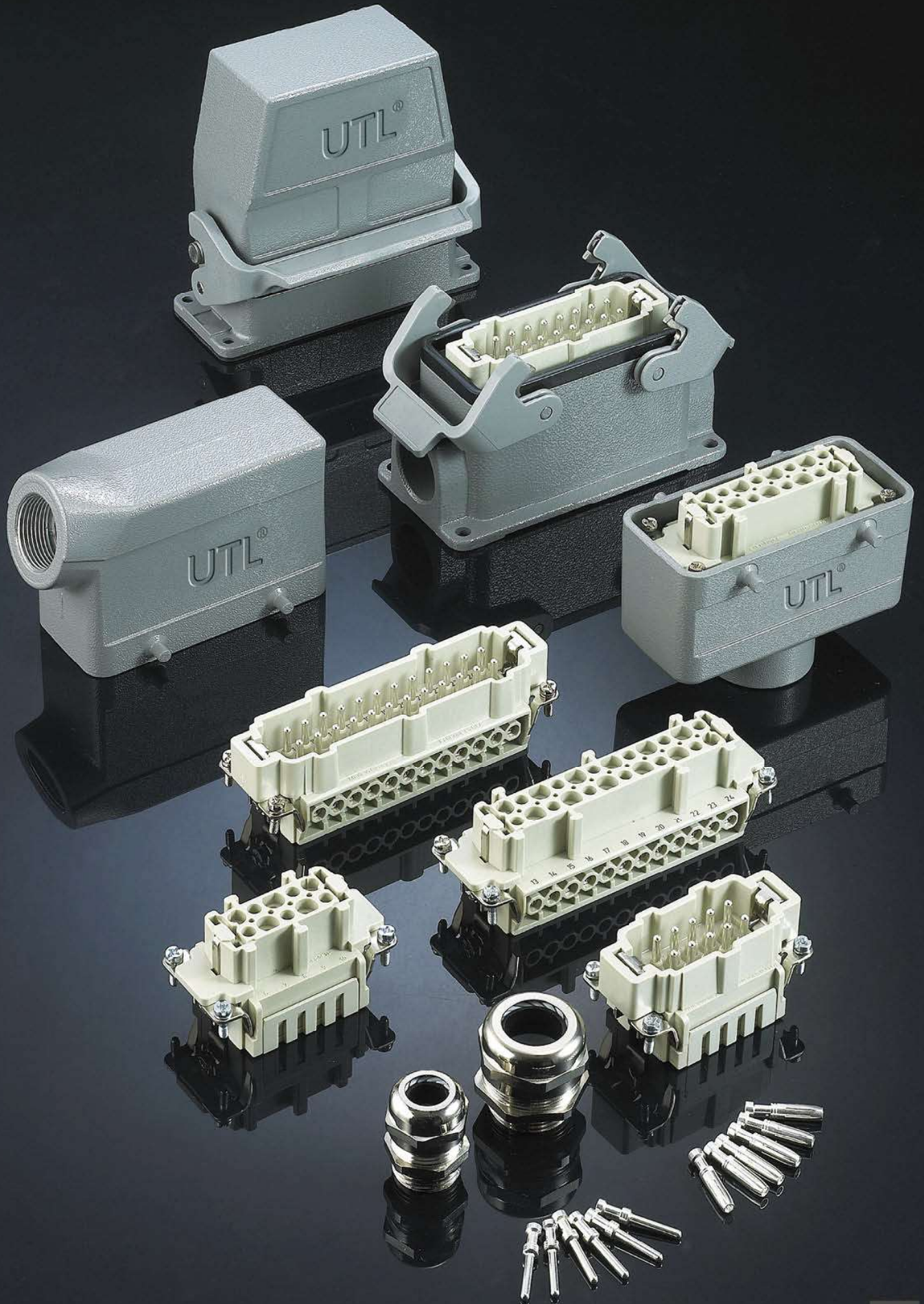

# Standard Inserts

## UTL-HE 系列常规型插芯

### 技术参数 Technical Characteristics

规范	Specifications	
规范	Specifications	DIN EN 60 664
		DIN EN 61 984
插芯	Inserts	
依据 EN 61 984的额定电压	Electrical data acc. to EN 61 984	
接插件针数	Number Of Contacts	6,10,16,24,32(2X16),48(2X24)+PE
-额定电流	-Rated Current	16A
-额定电压	-Rated Voltage	500V
-额定脉冲电压	-Rated Impulse Voltage	6kV
-污染程度	-Pollution Degree	3
-污染等级2时的参数	-Pollution Degree 2 Also	16A 400/690V 6kV 2
依据UL/CSA额定电压	Rated Voltage Acc. To UI CSA	600V
绝缘电阻	Insulation Resistance	$\geq 10^{10} \Omega$
材料	Material	聚碳酸酯 Polycarbonate
工作温度范围	Limiting Temperatures	-40°C...+125°C
依据UL94阻燃等级	Flammability Acc. To UL94	V0
可拔插次数	Mechanical Working Life-mating Cycles	$\geq 500$
插针	Contacts	
材料	Material	铜合金 Copper Alloy
表面处理	Surface	镀金 Hard-gold Plated 镀银 Hard-silver Plated
接触电阻	Contact Resistance	$\leq 1m\Omega$
螺钉连接	Screw Terminal	
-导线规格	-Wire Gauge	0.14-2.5mm <sup>2</sup>
-AWG	-AWG	26-14
-拧紧力矩	-Tightening Torque	0.5Nm
-剥线长度	-Stripping length	7.0mm
冷压连接	Crimp Terminal	
-导线规格	-Wire Gauge	0.14-4.0mm <sup>2</sup>
-AWG	-AWG	26-12
-剥线长度	-Stripping length	7.5mm
弹片连接	Cage-clamp	
-导线规格	-Wire Gauge	0.14-2.5mm <sup>2</sup>
-AWG	-AWG	26-14
-剥线长度	-Stripping length	7-9mm

### 电流负载能力 Current Carrying Capacity

电流负载能力所受的限制主要来自包含接插针的接插体可承受的最大温度

The current carrying is limited by maximum temperature of materials for inserts and contacts including terminals.

测试和控制过程依据 Measuring and testing techniques according to DIN EN 60512-5

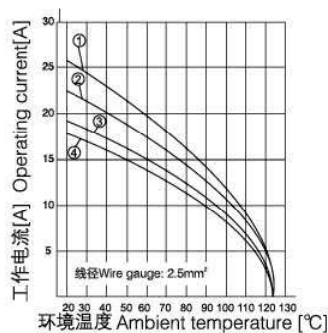

- ①UTL-HE-006-M/F(MC/FC)
- ②UTL-HE-010-M/F(MC/FC)
- ③UTL-HE-016-M/F(MC/FC)
- ④UTL-HE-024-M/F(MC/FC)

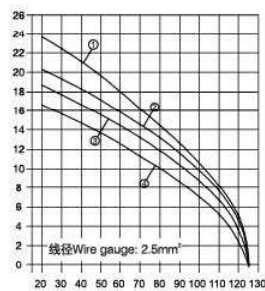

- ①UTL-HE-006-MS/FS
- ②UTL-HE-010-MS/FS
- ③UTL-HE-016-MS/FS
- ④UTL-HE-024-MS/FS

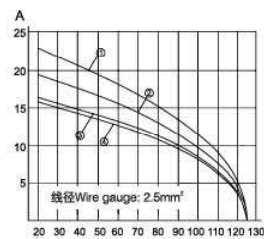

- ①UTL-HE-006-MSS/FSS
- ②UTL-HE-010-MSS/FSS
- ③UTL-HE-016-MSS/FSS
- ④UTL-HE-024-MSS/FSS





# Standard Inserts

## UTL-HE-010 常规型插芯 500V 16A 10+⊕

### 插芯 Inserts

外壳尺寸：匹配10B外壳，详情请参考16-01-16-13页

Hoods/Housings: Matching 10B Hood Housing, detail on P16-01~P16-13

#### 螺丝连接 Screw terminal



插芯 Inserts	型号 Type	订货号 Part Number
公 Male	UTL-HE-010-M	09330102601
母 Female	UTL-HE-010-F	09330102701

接插体之间的最大距离21mm  
Distance for contact max.21mm

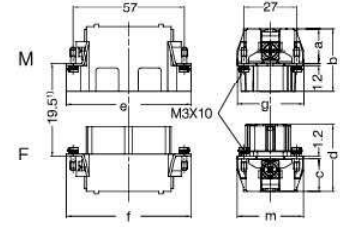

	a	b	e	g	c	d	f	m
M/F	16.5	32	64.5	34	16.8	34.2	64	34
MC/FC	18	33	64	34	17.5	35.2	64	34
MS/FSS	18.5	33.5	64	34	18.5	35.6	64	34
MSS/FSS	34	49	64	34	33.5	49.5	63	34
MZ/FZ	17.4	32.5	64	33.8	17.2	34.5	64	33.8

#### 接插针排序

Contacts arrangement view from termination side

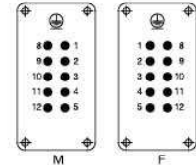

#### 面板安装开孔图

Panel cut out for inserts for use without Hoods/housings

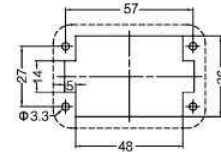

#### 冷压连接 Crimp terminal



插芯 Inserts	型号 Type	订货号 Part Number
公 Male	UTL-HE-010-MC	09330102602
母 Female	UTL-HE-010-FC	09330102702

#### 弹片连接 Cage-clamp

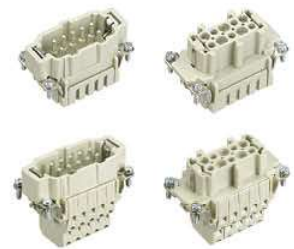

插芯 Inserts	型号 Type	订货号 Part Number
公 Male	UTL-HE-010-MS	09330102616
母 Female	UTL-HE-010-FS	09330102716

#### 双弹片连接(一针双接线) Cage-clamp terminal (two terminal per contact)

公 Male	UTL-HE-010-MSS	09330102672
母 Female	UTL-HE-010-FSS	09330102772

NEW



插芯 Inserts	型号 Type	订货号 Part Number
公 Male	UTL-HE-010-MZ	09330102801
母 Female	UTL-HE-010-FZ	09330102901

关于直插式弹片连接的优势，详见P00-14

### 附件 Accessories

#### 16A 冷压针 Crimp contacts

接触电阻 Contact resistance  $\leq 1m\Omega$   
镀银 Silver plated



#### 镀金 Gold plated



#### 工具 Tools

##### 冷压钳 Crimping tool



##### 退针器 Removal tool



公 Male	订货号 Part Number	母 Female	订货号 Part Number
CESM-0.37	09330006127	CESF-0.37	09330006227
CESM-0.5	09330006121	CESF-0.5	09330006220
CESM-0.75	09330006114	CESF-0.75	09330006214
CESM-1.0	09330006105	CESF-1.0	09330006205
CESM-1.5	09330006104	CESF-1.5	09330006204
CESM-2.5	09330006102	CESF-2.5	09330006202
CESM-3.0	09330006106	CESF-3.0	09330006206
CESM-4.0	09330006107	CESF-4.0	09330006207
CEGM-0.37	09330006117	CEGF-0.37	09330006217
CEGM-0.5	09330006122	CEGF-0.5	09330006222
CEGM-0.75	09330006115	CEGF-0.75	09330006215
CEGM-1.0	09330006118	CEGF-1.0	09330006218
CEGM-1.5	09330006116	CEGF-1.5	09330006216
CEGM-2.5	09330006123	CEGF-2.5	09330006223
CEGM-4.0	09330006119	CEGF-4.0	09330006221

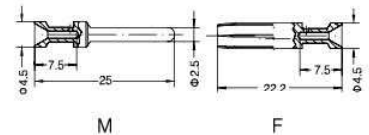

标示 Identification	线规 Wire gauge	剥线长度 Stripping length	
no groove	0.14-0.37mm <sup>2</sup>	AWG 26-22	7.5mm
no groove	0.5mm <sup>2</sup>	AWG 20	7.5mm
1 groove	0.75mm <sup>2</sup>	AWG 18	7.5mm
1 groove	1.0mm <sup>2</sup>	AWG 18	7.5mm
2 groove	1.5mm <sup>2</sup>	AWG 16	7.5mm
3 groove	2.5mm <sup>2</sup>	AWG 14	7.5mm
wide groove	3mm <sup>2</sup>	AWG 12	7.5mm
no groove	4mm <sup>2</sup>	AWG 12	7.5mm

压接线经 Wire gauge	型号 Type	订货号 Part Number
0.5-4mm <sup>2</sup>	TL02G	09990000021

适用类型 For	型号 Type	订货号 Part Number
16A 冷压针	TL01	09990000059
16A Crimp contacts		

更多工具请参考 25-01~25-02页 More tools on P25-01~P25-02

# Standard Inserts

## UTL-HE-016 常规型插芯 500V 16A 16+⊕

### 插芯 Inserts

外壳尺寸: 匹配16B外壳, 详情请参考17-01~17-21页

Hoods/Housings: Matching 16B Hood Housing, detail on P17-01~P17-21页

#### 螺丝连接 Screw terminal



插芯 Inserts	型号 Type	订货号 Part Number
公 Male	UTL-HE-016-M	09330162601
母 Female	UTL-HE-016-F	09330162701

接插体之间的最大距离21mm  
Distance for contact max.21mm

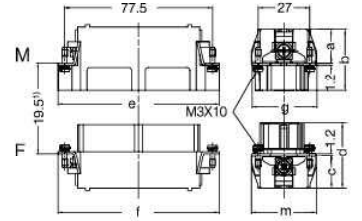

	a	b	e	g	c	d	f	m
M/F	17	32.5	84.2	34	17	34.5	84.2	33.5
MC/FC	18	33.5	84.5	34	18	35	84.5	34
MSS/FSS	34.3	49	84.5	34	32.2	49	84.5	34
MZ/FZ	17.4	32.5	84.5	33.8	17.2	34.5	84.5	33.8

#### 冷压连接 Crimp terminal



插芯 Inserts	型号 Type	订货号 Part Number
公 Male	UTL-HE-016-MC	09330162602
母 Female	UTL-HE-016-FC	09330162702

#### 弹片连接 Cage-clamp



插芯 Inserts	型号 Type	订货号 Part Number
公 Male	UTL-HE-016-MS	09330162616
母 Female	UTL-HE-016-FS	09330162716

#### 双弹片连接(一针双接线) Cage-clamp terminal (two terminal per contact)



公 Male	UTL-HE-016-MSS	09330162672
母 Female	UTL-HE-016-FSS	09330162772



插芯 Inserts	型号 Type	订货号 Part Number
公 Male	UTL-HE-016-MZ	09330162801
母 Female	UTL-HE-016-FZ	09330162901

关于直插式弹片连接的优势, 详见P00-14

#### 接插针排序

Contacts arrangement view from termination side

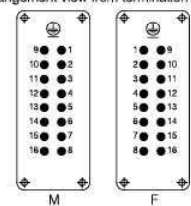

#### 面板安装开孔图

Panel cut out for inserts for use without Hoods/housings

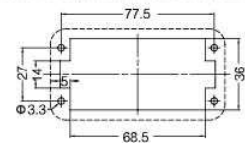

### 附件 Accessories

#### 16A 冷压针 Crimp contacts

接触电阻 Contact resistance  $\leq 1m\Omega$   
镀银 Silver plated



公 Male	订货号 Part Number	母 Female	订货号 Part Number
CESM-0.37	09330006127	CESF-0.37	09330006227
CESM-0.5	09330006121	CESF-0.5	09330006220
CESM-0.75	09330006114	CESF-0.75	09330006214
CESM-1.0	09330006105	CESF-1.0	09330006205
CESM-1.5	09330006104	CESF-1.5	09330006204
CESM-2.5	09330006102	CESF-2.5	09330006202
CESM-3.0	09330006106	CESF-3.0	09330006206
CESM-4.0	09330006107	CESF-4.0	09330006207

#### 镀金 Gold plated



CEGM-0.37	09330006117	CEGF-0.37	09330006217
CEGM-0.5	09330006122	CEGF-0.5	09330006222
CEGM-0.75	09330006115	CEGF-0.75	09330006215
CEGM-1.0	09330006118	CEGF-1.0	09330006218
CEGM-1.5	09330006116	CEGF-1.5	09330006216
CEGM-2.5	09330006123	CEGF-2.5	09330006223
CEGM-4.0	09330006119	CEGF-4.0	09330006221

#### 工具 Tools

##### 冷压钳 Crimping tool



##### 退针器 Remove



压接线经 Wire gauge	型号 Type	订货号 Part Number
0.5-4mm <sup>2</sup>	TL02G	09990000021

适用类型 For	型号 Type	订货号 Part Number
16A 冷压针 16A Crimp contacts	TL01	09990000059

更多工具请参考 25-01~25-02页 More tools on P25-01~P25-02

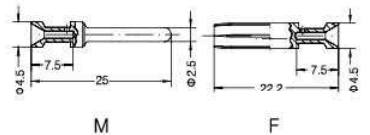

标示 Identification	线规 Wire gauge	剥线长度 Stripping length
no groove	0.14-0.37mm <sup>2</sup> AWG 26-22	7.5mm
no groove	0.5mm <sup>2</sup> AWG 20	7.5mm
1 groove	0.75mm <sup>2</sup> AWG 18	7.5mm
1 groove	1.0mm <sup>2</sup> AWG 18	7.5mm
2 groove	1.5mm <sup>2</sup> AWG 16	7.5mm
3 groove	2.5mm <sup>2</sup> AWG 14	7.5mm
wide groove	3mm <sup>2</sup> AWG 12	7.5mm
no groove	4mm <sup>2</sup> AWG 12	7.5mm



# Standard Inserts

## UTL-HE-032 常规型插芯 500V 16A 32+⊕

### 插芯 Inserts

外壳尺寸: 匹配32B外壳, 详情请参考19-01~19-04页

Hoods/Housings: Matching 32B Hood Housing, detail on P19-01~P19-04

#### 螺丝连接 Screw terminal



插芯 Inserts	型号 Type	订货号 Part Number
公 Male	UTL-HE-016-M(1-16)	09330162601
	UTL-HE-016-M(17-32)	09330162611
母 Female	UTL-HE-016-F(1-16)	09330162701
	UTL-HE-016-F(17-32)	09330162711

接插体之间的最大距离21mm

Distance for contact max.21mm

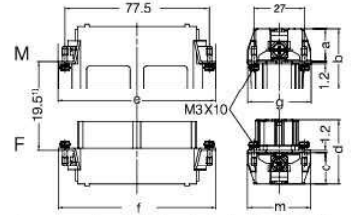

	a	b	e	g	c	d	f	m
M/F	17	32.5	84.2	34	17	34.5	84.2	33.5
MC/FC	18	33.5	84.5	34	18	35	84.5	34
MS/FS	18	33.7	84.5	34	18.2	35.5	84.5	34
MSS/FSS	34.3	49	84.5	34	32.2	49	84.5	34
MZ/FZ	17.4	32.5	84.5	33.8	17.2	34.5	84.5	33.8

#### 冷压连接 Crimp terminal



插芯 Inserts	型号 Type	订货号 Part Number
公 Male	UTL-HE-016-MC(1-16)	09330162602
	UTL-HE-016-MC(17-32)	09330162612
母 Female	UTL-HE-016-FC(1-16)	09330162702
	UTL-HE-016-FC(17-32)	09330162712

#### 弹片连接 Cage-clamp



插芯 Inserts	型号 Type	订货号 Part Number
公 Male	UTL-HE-016-MS(1-16)	09330162616
	UTL-HE-016-MS(17-32)	09330162626
母 Female	UTL-HE-016-FS(1-16)	09330162716
	UTL-HE-016-FS(17-32)	09330162726

#### 双弹片连接(一针双接线) Cage-clamp terminal (two terminal per contact)



公 Male	UTL-HE-016-MSS(1-16)	09330162672
	UTL-HE-016-MSS(17-32)	09330162672
母 Female	UTL-HE-016-FSS(1-16)	09330162772
	UTL-HE-016-FSS(17-32)	09330162772

#### 直插式弹片连接 Quick lock terminal



公 Male	UTL-HE-016-MZ(1-16)	09330162801
	UTL-HE-016-MZ(17-32)	09330162811
母 Female	UTL-HE-016-FZ(1-16)	09330162901
	UTL-HE-016-FZ(17-32)	09330162911

关于直插式弹片连接的优势, 详见P00-14

#### 接插针排序

Contacts arrangement view from termination side

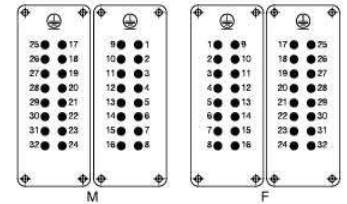

#### 面板安装开孔图

Panel cut out for inserts for use without Hoods/housings

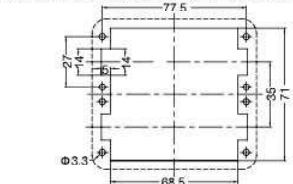

### 附件 Accessories

#### 16A 冷压针 Crimp contacts

接触电阻 Contact resistance  $\leq 1m\Omega$   
镀银 Silver plated



公 Male	订货号 Part Number	母 Female	订货号 Part Number
CESM-0.37	09330006127	CESF-0.37	09330006227
CESM-0.5	09330006121	CESF-0.5	09330006220
CESM-0.75	09330006114	CESF-0.75	09330006214
CESM-1.0	09330006105	CESF-1.0	09330006205
CESM-1.5	09330006104	CESF-1.5	09330006204
CESM-2.5	09330006102	CESF-2.5	09330006202
CESM-3.0	09330006106	CESF-3.0	09330006206
CESM-4.0	09330006107	CESF-4.0	09330006207

#### 镀金 Gold plated



CEGM-0.37	09330006117	CEGF-0.37	09330006217
CEGM-0.5	09330006122	CEGF-0.5	09330006222
CEGM-0.75	09330006115	CEGF-0.75	09330006215
CEGM-1.0	09330006118	CEGF-1.0	09330006218
CEGM-1.5	09330006116	CEGF-1.5	09330006216
CEGM-2.5	09330006123	CEGF-2.5	09330006223
CEGM-4.0	09330006119	CEGF-4.0	09330006221

#### 工具 Tools

#### 冷压钳 Crimping tool



#### 退针器 Remova



压接线径 Wire gauge	型号 Type	订货号 Part Number
0.5-4mm <sup>2</sup>	TL02G	09990000021

适用类型 For	型号 Type	订货号 Part Number
16A 冷压针 16A Crimp contacts	TL01	09990000059

更多工具请参考 25-01~25-02页 More tools on P25-01~P25-02

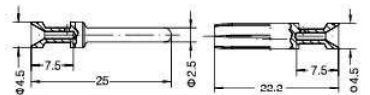

标示 Identification	线径 Wire gauge	剥线长度 Stripping length	
no groove	0.14-0.37mm <sup>2</sup>	AWG 26-22	7.5mm
no groove	0.5mm <sup>2</sup>	AWG 20	7.5mm
1 groove	0.75mm <sup>2</sup>	AWG 18	7.5mm
1 groove	1mm <sup>2</sup>	AWG 18	7.5mm
2 groove	1.5mm <sup>2</sup>	AWG 16	7.5mm
3 groove	2.5mm <sup>2</sup>	AWG 14	7.5mm
wide groove	3mm <sup>2</sup>	AWG 12	7.5mm
no groove	4mm <sup>2</sup>	AWG 12	7.5mm

# Standard Inserts

## UTL-HE-048 常规型插芯 500V 16A 48+⊕

### 插芯 Inserts

外壳尺寸: 匹配48B外壳, 详情请参考20-01~20-02页

Hoods/Housings: Matching 48B Hood Housing, detail on P20-01~P20-02

#### 螺丝连接 Screw terminal



插芯 Inserts	型号 Type	订货号 Part Number
公 Male	UTL-HE-024-M(1-24)	09330242601
	UTL-HE-024-M(25-48)	09330242611
母 Female	UTL-HE-024-F(1-24)	09330242701
	UTL-HE-024-F(25-48)	09330242711

接插体之间的最大距离21mm  
Distance for contact max.21mm

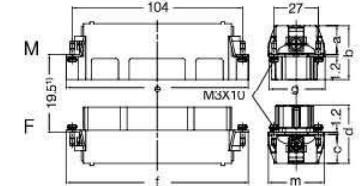

	a	b	ø	g	c	d	f	m
M/F	17	32.5	111	33.5	17	34.5	111	33.5
MC/FC	18.3	33.5	111	34	18.3	35.5	111	34
MS/FS	18.5	33.6	111	34	18.5	35.6	111	34
MSS/FSS	34	49	110	34	32	49	110	34
MZ/FZ	17.4	32.5	111	33.8	17.2	34.5	111	33.8

#### 冷压连接 Crimp terminal



插芯 Inserts	型号 Type	订货号 Part Number
公 Male	UTL-HE-024-MC(1-24)	09330242602
	UTL-HE-024-MC(25-48)	09330242612
母 Female	UTL-HE-024-FC(1-24)	09330242702
	UTL-HE-024-FC(25-48)	09330242712

#### 弹片连接 Cage-clamp



插芯 Inserts	型号 Type	订货号 Part Number
公 Male	UTL-HE-024-MS(1-24)	09330242616
	UTL-HE-024-MS(25-48)	09330242626
母 Female	UTL-HE-024-FS(1-24)	09330242716
	UTL-HE-024-FS(25-48)	09330242726

#### 接插针排序

Contacts arrangement view from termination side

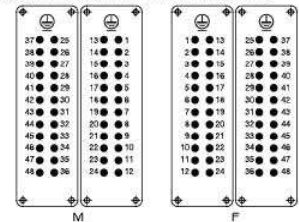

#### 面板安装开孔图

Panel cut out for inserts for use without Hoods/housings

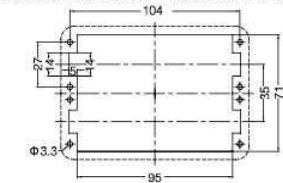

双弹片连接(一针双接线) Cage-clamp terminal (two terminal per contact)		
公 Male	UTL-HE-024-MSS(1-24)	09330242672
	UTL-HE-024-MSS(25-48)	09330242672
母 Female	UTL-HE-024-FSS(1-24)	09330242772
	UTL-HE-024-FSS(25-48)	09330242772



直插式弹片连接 Quick lock terminal		
公 Male	UTL-HE-024-MZ(1-24)	09330242801
	UTL-HE-024-MZ(25-48)	09330242811
母 Female	UTL-HE-024-FZ(1-24)	09330242901
	UTL-HE-024-FZ(25-48)	09330242911

关于直插式弹片连接的优势, 详见P00-14

### 附件 Accessories

#### 16A 冷压针 Crimp contacts

接触电阻 Contact resistance  $\leq 1m\Omega$   
镀银 Silver plated



公 Male	订货号 Part Number	母 Female	订货号 Part Number
CESM-0.37	09330006127	CESF-0.37	09330006227
CESM-0.5	09330006121	CESF-0.5	09330006220
CESM-0.75	09330006114	CESF-0.75	09330006214
CESM-1.0	09330006105	CESF-1.0	09330006205
CESM-1.5	09330006104	CESF-1.5	09330006204
CESM-2.5	09330006102	CESF-2.5	09330006202
CESM-3.0	09330006106	CESF-3.0	09330006206
CESM-4.0	09330006107	CESF-4.0	09330006207

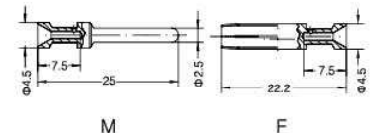

#### 镀金 Gold plated



CEGM-0.37	09330006117	CEGF-0.37	09330006217
CEGM-0.5	09330006122	CEGF-0.5	09330006222
CEGM-0.75	09330006115	CEGF-0.75	09330006215
CEGM-1.0	09330006118	CEGF-1.0	09330006218
CEGM-1.5	09330006116	CEGF-1.5	09330006216
CEGM-2.5	09330006123	CEGF-2.5	09330006223
CEGM-4.0	09330006119	CEGF-4.0	09330006221

#### 工具 Tools

##### 冷压钳 Crimping tool



##### 退针器 Removal tool



压接线径 Wire gauge	型号 Type	订货号 Part Number
0.5-4mm <sup>2</sup>	TL02G	09990000021

适用类型 For	型号 Type	订货号 Part Number
16A 冷压针 16A Crimp contacts	TL01	09990000059

更多工具请参考 25-01~25-02页 More tools on P25-01~P25-02

# UTL-HEE 系列 / HEE SERIES

高密度型连接器 / High-density Connector

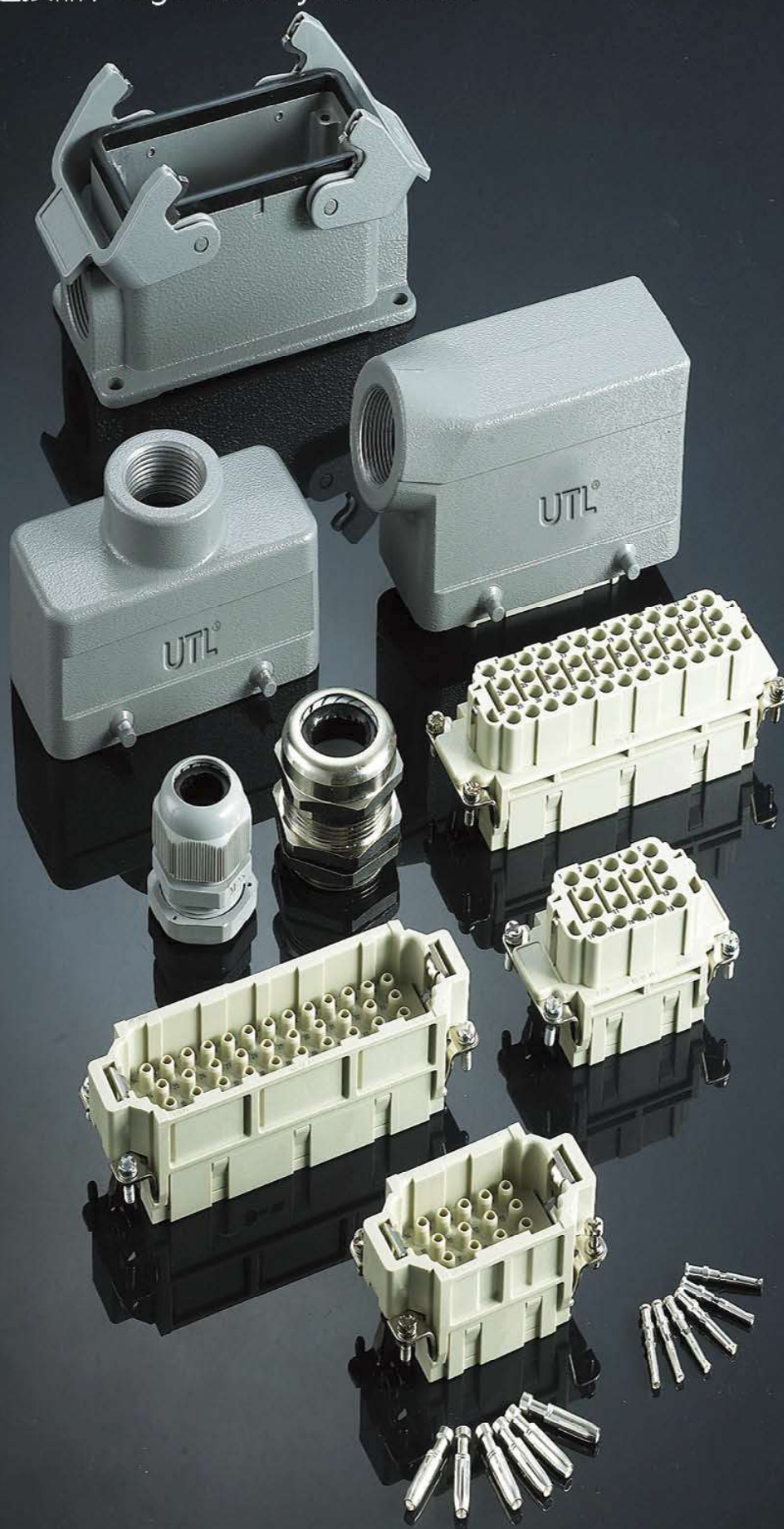

# High-density Inserts

## UTL-HEE 高密度型插芯

### 技术参数 Technical Characteristics

规范	Specifications	
规范	Specifications	DIN EN 60 664
		DIN EN 61 984
插芯	Inserts	
依据 EN 61 984的额定电压	Electrical data acc. to EN 61 984	
接插件针数	Number Of Contacts	10,18,32,46,40,64(2X32),92(2X46)+PE
额定电流	Rated Current	16A
额定电压	Rated Voltage	500V
额定脉冲电压	Rated Impulse Voltage	6kV
污染程度	Pollution Degree	3
污染等级2时的参数	Pollution Degree 2 Also	16A 830V 8kV 2
依据UL/CSA额定电压	Rated Voltage Acc.to UI CSA	600V
绝缘电阻	Insulation Resistance	$\geq 10^{10} \Omega$
材料	Material	聚碳酸酯 Polycarbonate
工作温度范围	Limiting Temperatures	-40°C...+125°C
依据UL94阻燃等级	Flammability Acc. To UL94	V0
可拔插次数	Mechanical Working Life-mating Cycles	$\geq 500$
插针	Contacts	
材料	Material	铜合金 Copper Alloy
表面处理	Surface	镀金 Hard-gold Plated 镀银 Hard-silver Plated
接触电阻	Contact Resistance	$\leq 1m \Omega$
冷压连接	Crimp Terminal	
导线规格	Wire Gauge	0.14-4.0mm <sup>2</sup>
AWG	Awg	26-12
剥线长度	Stripping length	7.5mm

### 电流负载能力 Current Carrying Capacity

电流负载能力所受的限制主要来自包含接插针的接插体可承受的最大温度

THEE current carrying is limited by maximum temperature of materials for Inserts and contacts including terminals.

测试和控制过程依据 Measuring and testing techniques according to DIN EN 60512-5

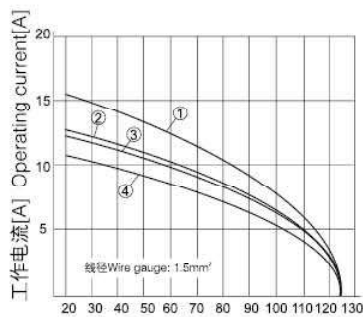

环境温度 Ambient temperature [°C]

- ①UTL-HEE-010
- ②UTL-HEE-018
- ③UTL-HEE-032
- ④UTL-HEE-046

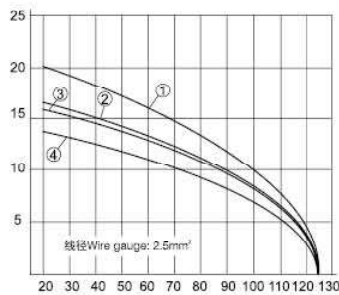

- ①UTL-HEE-010
- ②UTL-HEE-018
- ③UTL-HEE-032
- ④UTL-HEE-046

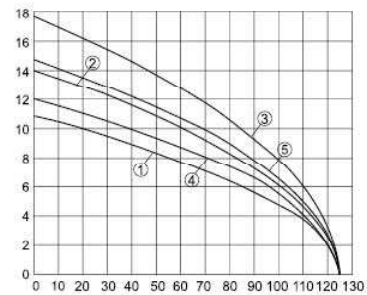

- ①UTL-HEE-064/1.5mm<sup>2</sup>
- ②UTL-HEE-064/2.5mm<sup>2</sup>
- ③UTL-HEE-064/4.0mm<sup>2</sup>
- ④UTL-HEE-040/1.5mm<sup>2</sup>
- ⑤UTL-HEE-040/1.5mm<sup>2</sup>



# High-density Inserts

## UTL-HEE 高密度型插芯

### UTL-HEE调整插针分布可提高工作电压至1000V/Modified contact arrangement up to 1000V

UTL-HEE接插体在装满针时,在绝缘等级3(C)时,其工作电压可达到500V。但其插针分布经过调整,同样在绝缘等级3(C)时,其工作电压允许值可达到1000V。

The connector series HEE equipped with all contacts may be used for voltages up to 500V ~ pollution degree 3.A modified contact loading arrangement permits use up to 1000V ~ pollution degree also in pollution degree C.

### 调整后插针分布 Contact arrangement view from termination side

690V-绝缘等级3C Pollution degree 3

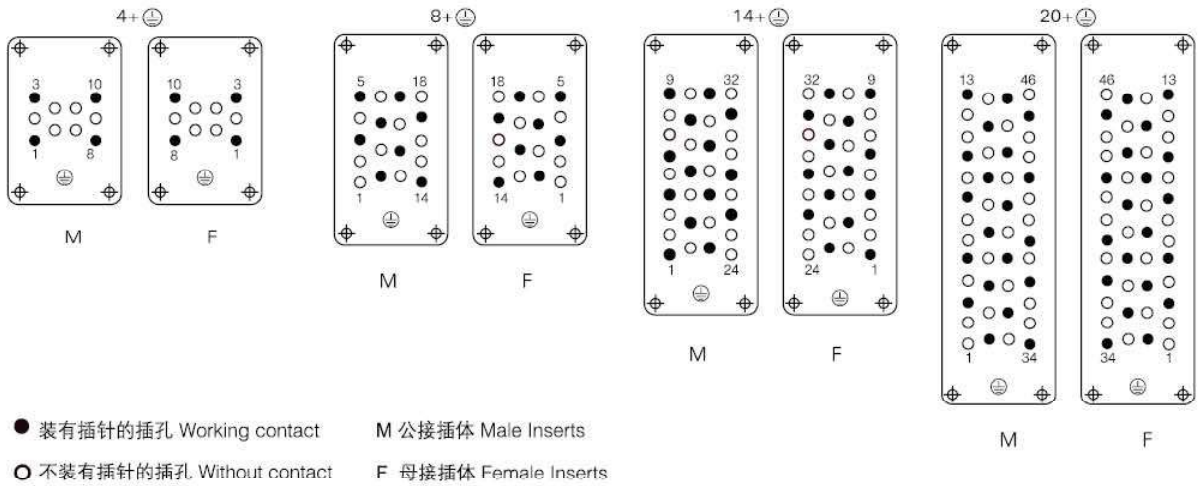

### 调整后插针分布 Contact arrangement view from termination side

1000V-绝缘等级3C Pollution degree 3

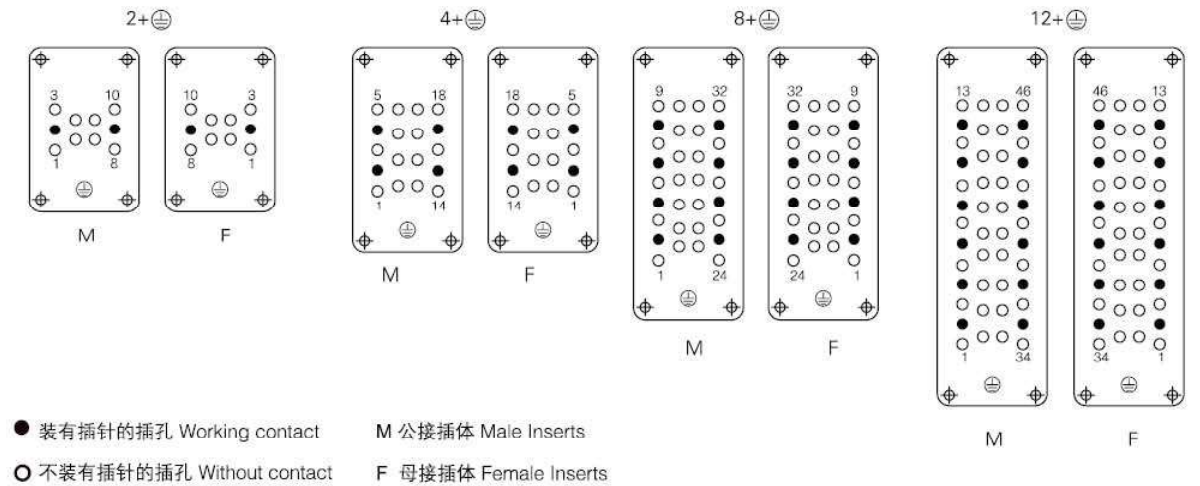

# High-density Inserts

## UTL-HEE-018 高密度型插芯 500V 16A 18+⊕

### 插芯 Inserts

外壳尺寸：匹配6B外壳，详情请参考15-01~15-10页

Hoods/Housings: Matching 6B Hood Housing, detail on P15-01~P15-10

冷压连接 Crimp terminal



插芯 Inserts	型号 Type	订货号 Part Number
公 Male	UTL-HEE-010-MC	09320103001
母 Female	UTL-HEE-010-FC	09320103101

接插体之间的最大距离21mm  
Distance for contact max.21mm

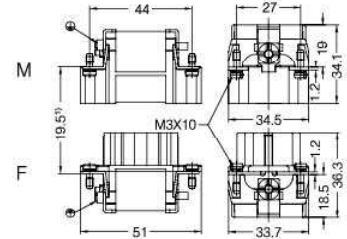

接插针排序

Contacts arrangement view from termination side

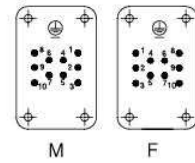

面板安装开孔图

Panel cut out for inserts for use without Hoods/housing

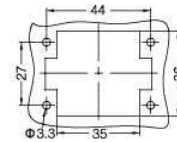

### 附件 Accessories

16A 冷压针 Crimp contacts

接触电阻 Contact resistance  $\leq 1m\Omega$   
镀银 Silver plated



镀金 Gold plated



工具 Tools

冷压钳 Crimping tool



退针器 Removal tool



公 Male	订货号 Part Number	母 Female	订货号 Part Number
CESM-0.37	09330006127	CESF-0.37	09330006227
CESM-0.5	09330006121	CESF-0.5	09330006220
CESM-0.75	09330006114	CESF-0.75	09330006214
CESM-1.0	09330006105	CESF-1.0	09330006205
CESM-1.5	09330006104	CESF-1.5	09330006204
CESM-2.5	09330006102	CESF-2.5	09330006202
CESM-3.0	09330006106	CESF-3.0	09330006206
CESM-4.0	09330006107	CESF-4.0	09330006207

公 Male	订货号 Part Number	母 Female	订货号 Part Number
CEGM-0.37	09330006117	CEGF-0.37	09330006217
CEGM-0.5	09330006122	CEGF-0.5	09330006222
CEGM-0.75	09330006115	CEGF-0.75	09330006215
CEGM-1.0	09330006118	CEGF-1.0	09330006218
CEGM-1.5	09330006116	CEGF-1.5	09330006216
CEGM-2.5	09330006123	CEGF-2.5	09330006223
CEGM-4.0	09330006119	CEGF-4.0	09330006221

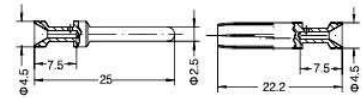

标示 Identification	线规 Wire gauge	剥线长度 Stripping length	
no groove	014-0.37mm <sup>2</sup>	AWG 26-22	7.5mm
no groove	0.5mm <sup>2</sup>	AWG 20	7.5mm
1 groove	0.75mm <sup>2</sup>	AWG 18	7.5mm
1 groove	1.1mm <sup>2</sup>	AWG 18	7.5mm
2 groove	1.5mm <sup>2</sup>	AWG 16	7.5mm
3 groove	2.5mm <sup>2</sup>	AWG 14	7.5mm
wide groove	3mm <sup>2</sup>	AWG 12	7.5mm
no groove	4mm <sup>2</sup>	AWG 12	7.5mm

压接线经 Wire gauge	型号 Type	订货号 Part Number
0.5-4mm <sup>2</sup>	TL02G	09990000021

适用类型 For	型号 Type	订货号 Part Number
16A 冷压针	TL01	09990000059
16A Crimp contacts		

更多工具请参考 25-01~25-02页 More tools on P25-01~P25-02

# High-density Inserts

## UTL-HEE-018 高密度型插芯 500V 16A 18+⊕

### 插芯 Inserts

外壳尺寸：匹配10B外壳，详情请参考16-01~16-13页

Hoods/Housings: Matching 10B Hood Housing, detail on P16-01~P16-13

冷压连接 Crimp terminal



插芯 Inserts	型号 Type	订货号 Part Number
公 Male	UTL-HEE-018-MC	09320183001
母 Female	UTL-HEE-018-FC	09320183101

接插体之间的最大距离21mm  
Distance for contact max.21mm

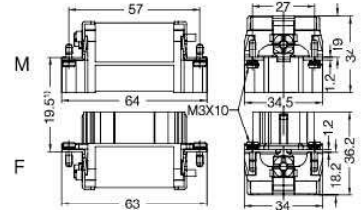

接插针排序

Contacts arrangement view from termination side

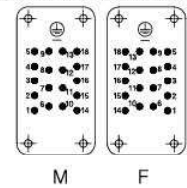

面板安装开孔图

Panel cut out for Inserts for use without Hoods/Housings

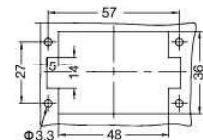

### 附件 Accessories

16A 冷压针 Crimp contacts

接触电阻 Contact resistance  $\leq 1m\Omega$   
镀银 Silver plated



镀金 Gold plated



工具 Tools

冷压钳 Crimping tool



退针器 Removal tool



公 Male	订货号 Part Number	母 Female	订货号 Part Number
CESM-0.37	09330006127	CESF-0.37	09330006227
CESM-0.5	09330006121	CESF-0.5	09330006220
CESM-0.75	09330006114	CESF-0.75	09330006214
CESM-1.0	09330006105	CESF-1.0	09330006205
CESM-1.5	09330006104	CESF-1.5	09330006204
CESM-2.5	09330006102	CESF-2.5	09330006202
CESM-3.0	09330006106	CESF-3.0	09330006206
CESM-4.0	09330006107	CESF-4.0	09330006207

公 Male	订货号 Part Number	母 Female	订货号 Part Number
CEGM-0.37	09330006117	CEGF-0.37	09330006217
CEGM-0.5	09330006122	CEGF-0.5	09330006222
CEGM-0.75	09330006115	CEGF-0.75	09330006215
CEGM-1.0	09330006118	CEGF-1.0	09330006218
CEGM-1.5	09330006116	CEGF-1.5	09330006216
CEGM-2.5	09330006123	CEGF-2.5	09330006223
CEGM-4.0	09330006119	CEGF-4.0	09330006221

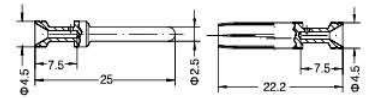

标示 Identification	线规 Wire gauge	剥线长度 Stripping length
no groove	0.14-0.37mm <sup>2</sup> AWG 26-22	7.5mm
no groove	0.5mm <sup>2</sup> AWG 20	7.5mm
1 groove	0.75mm <sup>2</sup> AWG 18	7.5mm
1 groove	1.0mm <sup>2</sup> AWG 18	7.5mm
2 groove	1.5mm <sup>2</sup> AWG 16	7.5mm
3 groove	2.5mm <sup>2</sup> AWG 14	7.5mm
wide groove	3mm <sup>2</sup> AWG 12	7.5mm
no groove	4mm <sup>2</sup> AWG 12	7.5mm

压接线经 Wire gauge	型号 Type	订货号 Part Number
0.5-4mm <sup>2</sup>	TL02G	09990000021

适用类型 For	型号 Type	订货号 Part Number
16A 冷压针	TL01	09990000059
16A Crimp contacts		

更多工具请参考 25-01~25-02页 More tools on P25-01~P25-02

# High-density Inserts

## UTL-HEE-032 高密度型插芯 500V 16A 32+⊕

### 插芯 Inserts

外壳尺寸: 匹配16B外壳, 详情请参考17-01~17-21页

Hoods/Housings: Matching 16B Hood Housing, detail on P17-01~P17-21页

冷压连接 Crimp terminal



插芯 Inserts	型号 Type	订货号 Part Number
公 Male	UTL-HEE-032-MC	09320323001
母 Female	UTL-HEE-032-FC	09320323101

接插体之间的最大距离21mm  
Distance for contact max.21mm

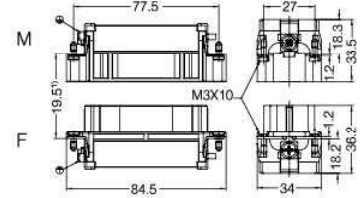

接插针排序

Contacts arrangement view from termination side

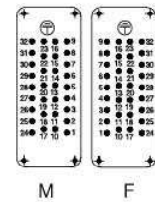

面板安装开孔图

Panel cut out for Inserts for use without Hoods/housings

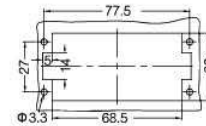

### 附件 Accessories

16A 冷压针 Crimp contacts

接触电阻 Contact resistance  $\leq 1m\Omega$   
镀银 Silver plated



镀金 Gold plated



工具 Tools

冷压钳 Crimping tool



退针器 Removal tool



公 Male	订货号 Part Number	母 Female	订货号 Part Number
CESM-0.37	09330006127	CESF-0.37	09330006227
CESM-0.5	09330006121	CESF-0.5	09330006220
CESM-0.75	09330006114	CESF-0.75	09330006214
CESM-1.0	09330006105	CESF-1.0	09330006205
CESM-1.5	09330006104	CESF-1.5	09330006204
CESM-2.5	09330006102	CESF-2.5	09330006202
CESM-3.0	09330006106	CESF-3.0	09330006206
CESM-4.0	09330006107	CESF-4.0	09330006207

公 Male	订货号 Part Number	母 Female	订货号 Part Number
CEGM-0.37	09330006117	CEGF-0.37	09330006217
CEGM-0.5	09330006122	CEGF-0.5	09330006222
CEGM-0.75	09330006115	CEGF-0.75	09330006215
CEGM-1.0	09330006118	CEGF-1.0	09330006218
CEGM-1.5	09330006116	CEGF-1.5	09330006216
CEGM-2.5	09330006123	CEGF-2.5	09330006223
CEGM-4.0	09330006119	CEGF-4.0	09330006221

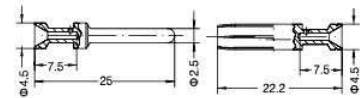

标示 Identification	线规 Wire gauge	剥线长度 Stripping length	
no groove	0.14-0.37mm <sup>2</sup>	AWG 26-22	7.5mm
no groove	0.5mm <sup>2</sup>	AWG 20	7.5mm
1 groove	0.75mm <sup>2</sup>	AWG 18	7.5mm
1 groove	1.0mm <sup>2</sup>	AWG 18	7.5mm
2 groove	1.5mm <sup>2</sup>	AWG 16	7.5mm
3 groove	2.5mm <sup>2</sup>	AWG 14	7.5mm
wide groove	3mm <sup>2</sup>	AWG 12	7.5mm
no groove	4mm <sup>2</sup>	AWG 12	7.5mm

压接线经 Wire gauge	型号 Type	订货号 Part Number
0.5-4mm <sup>2</sup>	TL02G	09990000021

适用类型 For	型号 Type	订货号 Part Number
16A 冷压针 16A Crimp contacts	TL01	09990000059

更多工具请参考 25-01~25-02页 More tools on P25-01~P25-02

# High-density Inserts

## UTL-HEE-046 高密度型插芯 500V 16A 46+⊕

### 插芯 Inserts

外壳尺寸：匹配24B外壳，详情请参考18-01-18-22页

Hoods/Housings: Matching 24B Hood Housing, detail on P18-01~P18-22

冷压连接 Crimp terminal



插芯 Inserts	型号 Type	订货号 Part Number
公 Male	UTL-HEE-046-MC	09320463001
母 Female	UTL-HEE-046-FC	09320463101

接插体之间的最大距离21mm  
Distance for contact max.21mm

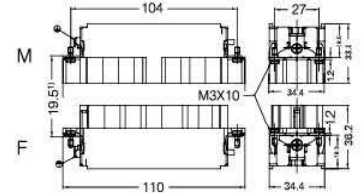

### 接插针排序

Contacts arrangement view from termination side

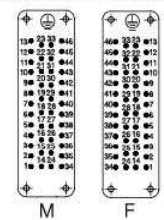

### 面板安装开孔图

Panel cut out for Inserts for use without Hoods/housings

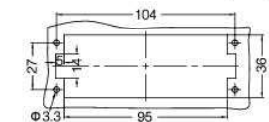

### 附件 Accessories

16A 冷压针 Crimp contacts

接触电阻 Contact resistance  $\leq 1m\Omega$   
镀银 Silver plated



镀金 Gold plated



工具 Tools

冷压钳 Crimping tool



退针器 Removal tool



公 Male	订货号 Part Number	母 Female	订货号 Part Number
CESM-0.37	09330006127	CESF-0.37	09330006227
CESM-0.5	09330006121	CESF-0.5	09330006220
CESM-0.75	09330006114	CESF-0.75	09330006214
CESM-1.0	09330006105	CESF-1.0	09330006205
CESM-1.5	09330006104	CESF-1.5	09330006204
CESM-2.5	09330006102	CESF-2.5	09330006202
CESM-3.0	09330006106	CESF-3.0	09330006206
CESM-4.0	09330006107	CESF-4.0	09330006207

公 Male	订货号 Part Number	母 Female	订货号 Part Number
CEGM-0.37	09330006117	CEGF-0.37	09330006217
CEGM-0.5	09330006122	CEGF-0.5	09330006222
CEGM-0.75	09330006115	CEGF-0.75	09330006215
CEGM-1.0	09330006118	CEGF-1.0	09330006218
CEGM-1.5	09330006116	CEGF-1.5	09330006216
CEGM-2.5	09330006123	CEGF-2.5	09330006223
CEGM-4.0	09330006119	CEGF-4.0	09330006221

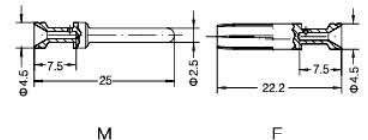

标示 Identification	线规 Wire gauge	剥线长度 Shipping length
no groove	0.14-0.37mm <sup>2</sup> AWG 26-22	7.5mm
1 groove	0.5mm <sup>2</sup> AWG 20	7.5mm
2 groove	0.75mm <sup>2</sup> AWG 18	7.5mm
3 groove	1.0mm <sup>2</sup> AWG 16	7.5mm
wide groove	1.5mm <sup>2</sup> AWG 14	7.5mm
no groove	2.5mm <sup>2</sup> AWG 12	7.5mm
no groove	4mm <sup>2</sup> AWG 12	7.5mm

压接线经 Wire gauge	型号 Type	订货号 Part Number
0.5-4mm <sup>2</sup>	TL02G	09990000021

适用类型 For	型号 Type	订货号 Part Number
16A 冷压针 16A Crimp contacts	TL01	09990000059

更多工具请参考 25-01~25-02页 More tools on P25-01~P25-02

# High-density Inserts

## UTL-HEE-064 高密度型插芯 500V 16A 64+⊕

### 插芯 Inserts

外壳尺寸: 匹配32B外壳, 详情请参考19-01~19-04页

Hoods/Housings: Matching 32B Hood Housing, detail on P19-01~P19-04

冷压连接 Crimp terminal



插芯 Inserts	型号 Type	订货号 Part Number
公 Male	UTL-HEE-032-MC(1-32)	09320323001
	UTL-HEE-032-MC(33-64)	09320323011
母 Female	UTL-HEE-032-FC(1-32)	09320323101
	UTL-HEE-032-FC(33-64)	09320323111

接插体之间的最大距离21mm

Distance for contact max.21mm

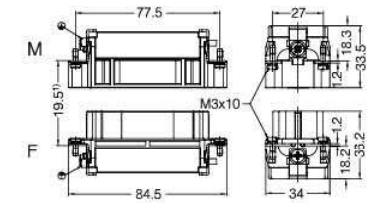

接插针排序

Contacts arrangement view from termination side

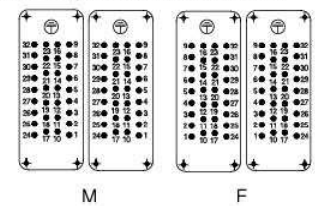

面板安装开孔图

Panel cut out for Inserts for use without Hoods/housings

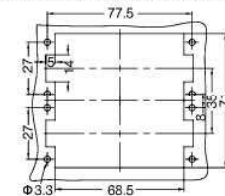

### 附件 Accessories

16A 冷压针 Crimp contacts

接触电阻 Contact resistance  $\leq 1m\Omega$

镀银 Silver plated



镀金 Gold plated



工具 Tools

冷压钳 Crimping tool



退针器 Removal tool



公 Male	订货号 Part Number	母 Female	订货号 Part Number
CESM-0.37	09330006127	CESF-0.37	09330006227
CESM-0.5	09330006121	CESF-0.5	09330006220
CESM-0.75	09330006114	CESF-0.75	09330006214
CESM-1.0	09330006105	CESF-1.0	09330006205
CESM-1.5	09330006104	CESF-1.5	09330006204
CESM-2.5	09330006102	CESF-2.5	09330006202
CESM-3.0	09330006106	CESF-3.0	09330006206
CESM-4.0	09330006107	CESF-4.0	09330006207

公 Male	订货号 Part Number	母 Female	订货号 Part Number
CEGM-0.37	09330006117	CEGF-0.37	09330006217
CEGM-0.5	09330006122	CEGF-0.5	09330006222
CEGM-0.75	09330006115	CEGF-0.75	09330006215
CEGM-1.0	09330006118	CEGF-1.0	09330006218
CEGM-1.5	09330006116	CEGF-1.5	09330006216
CEGM-2.5	09330006123	CEGF-2.5	09330006223
CEGM-4.0	09330006119	CEGF-4.0	09330006221

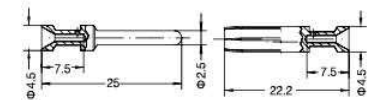

标示 Identification	线规 Wire gauge	剥线长度 Stripping length
no groove	0.14-0.37mm <sup>2</sup>	AWG 26-22 7.5mm
no groove	0.5mm <sup>2</sup>	AWG 20 7.5mm
1 groove	0.75mm <sup>2</sup>	AWG 18 7.5mm
1 groove	1.0mm <sup>2</sup>	AWG 18 7.5mm
2 groove	1.5mm <sup>2</sup>	AWG 16 7.5mm
3 groove	2.5mm <sup>2</sup>	AWG 14 7.5mm
wide groove	3mm <sup>2</sup>	AWG 12 7.5mm
no groove	4mm <sup>2</sup>	AWG 12 7.5mm

压接线径 Wire gauge	型号 Type	订货号 Part Number
0.5-4mm <sup>2</sup>	TL02G	09990000021

适用类型 For	型号 Type	订货号 Part Number
16A 冷压针	TL01	09990000059
16A Crimp contacts		

更多工具请参考 25-01~25-02页 More tools on P25-01~P25-02

# High-density Inserts

## UTL-HEE-092 高密度型插芯 500V 16A 92+⊕

### 插芯 Inserts

外壳尺寸：匹配48B外壳，详情请参考20-01~20-02页

Hoods/Housings: Matching 48B Hood Housing, detail on P20-01~P20-02

冷压连接 Crimp terminal



插芯 Inserts	型号 Type	订货号 Part Number
公 Male	UTL-HEE-046-MC(1-46)	09320463001
	UTL-HEE-046-MC(47-92)	09320463011
母 Female	UTL-HEE-046-FC(1-46)	09320463101
	UTL-HEE-046-FC(47-92)	09320463111

接插体之间的最大距离21mm  
Distance for contact max.21mm

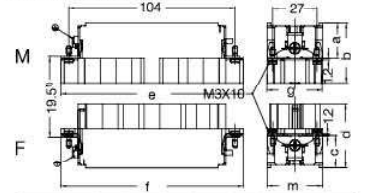

	a	b	e	g	c	d	f	m
M/F	18.5	33.8	110.5	34.4	18.3	36.2	110	34.4
MC/FC	18.3	33.8	110	34.4	18.2	36.2	110	34.4

接插针排序

Contacts arrangement view from termination side

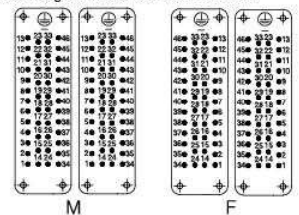

面板安装开孔图

Panel cut out for inserts for use without Hoods/Housings

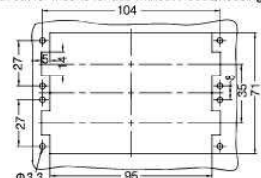

### 附件 Accessories

16A 冷压针 Crimp contacts

接触电阻 Contact resistance  $\leq 1m\Omega$   
镀银 Silver plated



镀金 Gold plated



工具 Tools

冷压钳 Crimping tool



退针器 Removal tool



公 Male	订货号 Part Number	母 Female	订货号 Part Number
CESM-0.37	09330006127	CESF-0.37	09330006227
CESM-0.5	09330006121	CESF-0.5	09330006220
CESM-0.75	09330006114	CESF-0.75	09330006214
CESM-1.0	09330006105	CESF-1.0	09330006205
CESM-1.5	09330006104	CESF-1.5	09330006204
CESM-2.5	09330006102	CESF-2.5	09330006202
CESM-3.0	09330006106	CESF-3.0	09330006206
CESM-4.0	09330006107	CESF-4.0	09330006207

公 Male	订货号 Part Number	母 Female	订货号 Part Number
CEGM-0.37	09330006117	CEGF-0.37	09330006217
CEGM-0.5	09330006122	CEGF-0.5	09330006222
CEGM-0.75	09330006115	CEGF-0.75	09330006215
CEGM-1.0	09330006118	CEGF-1.0	09330006218
CEGM-1.5	09330006116	CEGF-1.5	09330006216
CEGM-2.5	09330006123	CEGF-2.5	09330006223
CEGM-4.0	09330006119	CEGF-4.0	09330006221

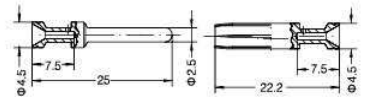

标示 Identification	线规 Wire gauge	剥线长度 Stripping length
no groove	0.14-0.37mm <sup>2</sup> AWG 26-22	7.5mm
no groove	0.5mm <sup>2</sup> AWG 20	7.5mm
1 groove	0.75mm <sup>2</sup> AWG 18	7.5mm
1 groove	1.0mm <sup>2</sup> AWG 18	7.5mm
2 groove	1.5mm <sup>2</sup> AWG 16	7.5mm
3 groove	2.5mm <sup>2</sup> AWG 14	7.5mm
wide groove	3mm <sup>2</sup> AWG 12	7.5mm
no groove	4mm <sup>2</sup> AWG 12	7.5mm

压接线经 Wire gauge	型号 Type	订货号 Part Number
0.5-4mm <sup>2</sup>	TL02G	09990000021

适用类型 For	型号 Type	订货号 Part Number
16A 冷压针 16A Crimp contacts	TL01	09990000059

更多工具请参考 25-01~25-02页 More tools on P25-01~P25-02

# High-density Inserts

## UTL-HEEE-040 高密度型插芯 500V 16A 40+ ⊕

### 插芯 Inserts

外壳尺寸: 匹配16B外壳, 详情请参考17-01~17-21页

Hoods/Housings: Matching 16B Hood Housing, detail on P17-01~P17-21页

冷压连接 Crimp terminal



插芯 Inserts	型号 Type	订货号 Part Number
公 Male	UTL-HEEE-040-MC	09320403001
母 Female	UTL-HEEE-040-FC	09320403101

接插体之间的最大距离21mm  
Distance for contact max.21mm

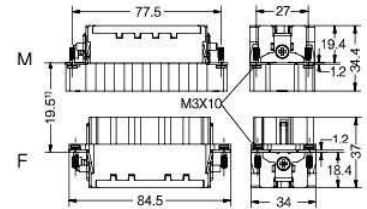

接插针排序

Contacts arrangement view from termination side

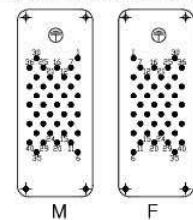

面板安装开孔图

Panel cut out for Inserts for use without Hoods/housings

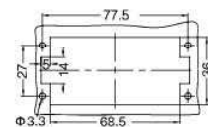

### 附件 Accessories

16A 冷压针 Crimp contacts

接触电阻 Contact resistance  $\leq 1m\Omega$   
镀银 Silver plated



镀金 Gold plated



工具 Tools

冷压钳 Crimping tool



退针器 Removal tool



公 Male	订货号 Part Number	母 Female	订货号 Part Number
CESM-0.37	09330006127	CESF-0.37	09330006227
CESM-0.5	09330006121	CESF-0.5	09330006220
CESM-0.75	09330006114	CESF-0.75	09330006214
CESM-1.0	09330006105	CESF-1.0	09330006205
CESM-1.5	09330006104	CESF-1.5	09330006204
CESM-2.5	09330006102	CESF-2.5	09330006202
CESM-3.0	09330006106	CESF-3.0	09330006206
CESM-4.0	09330006107	CESF-4.0	09330006207

公 Male	订货号 Part Number	母 Female	订货号 Part Number
CEGM-0.37	09330006117	CEGF-0.37	09330006217
CEGM-0.5	09330006122	CEGF-0.5	09330006222
CEGM-0.75	09330006115	CEGF-0.75	09330006215
CEGM-1.0	09330006118	CEGF-1.0	09330006218
CEGM-1.5	09330006116	CEGF-1.5	09330006216
CEGM-2.5	09330006123	CEGF-2.5	09330006223
CEGM-4.0	09330006119	CEGF-4.0	09330006221

压接线经 Wire gauge	型号 Type	订货号 Part Number
0.5-4mm <sup>2</sup>	TL02G	09990000021

适用类型 For	型号 Type	订货号 Part Number
16A 冷压针 16A Crimp contacts	TL01	09990000059

更多工具请参考 25-01~25-02页 More tools on P25-01~P25-02

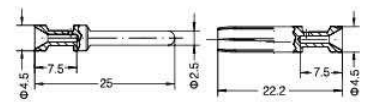

标示 Identification	线规 Wire gauge	剥线长度 Stripping length	
no groove	0.14-0.37mm <sup>2</sup>	AWG 26-22	7.5mm
no groove	0.5mm <sup>2</sup>	AWG 20	7.5mm
1 groove	0.75mm <sup>2</sup>	AWG 18	7.5mm
1 groove	1.1mm <sup>2</sup>	AWG 18	7.5mm
2 groove	1.5mm <sup>2</sup>	AWG 16	7.5mm
3 groove	2.5mm <sup>2</sup>	AWG 14	7.5mm
wide groove	3mm <sup>2</sup>	AWG 12	7.5mm
no groove	4mm <sup>2</sup>	AWG 12	7.5mm



# High-density Inserts

## UTL-HEEE-064 高密度型插芯 500V 16A 64+ Ⓟ

### 插芯 Inserts

外壳尺寸：匹配24B外壳，详情请参考18-01-18-22页

Hoods/Housings: Matching 24B Hood Housing, detail on P18-01-P18-22

冷压连接 Crimp terminal



插芯 Inserts	型号 Type	订货号 Part Number
公 Male	UTL-HEEE-064-MC	09320643001
母 Female	UTL-HEEE-064-FC	09320643101

接插体之间的最大距离21mm  
Distance for contact max.21mm

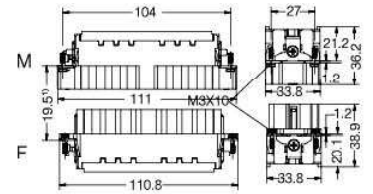

接插针排序

Contacts arrangement view from termination side

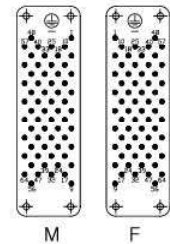

面板安装开孔图

Panel cut out for Inserts for use without Hoods/housings

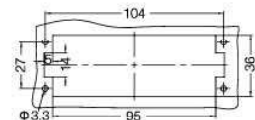

### 附件 Accessories

16A 冷压针 Crimp contacts

接触电阻 Contact resistance  $\leq 1m\Omega$   
镀银 Silver plated



镀金 Gold plated



工具 Tools

冷压钳 Crimping tool



退针器 Removal tool



公 Male	订货号 Part Number	母 Female	订货号 Part Number
CESM-0.37	09330006127	CESF-0.37	09330006227
CESM-0.5	09330006121	CESF-0.5	09330006220
CESM-0.75	09330006114	CESF-0.75	09330006214
CESM-1.0	09330006105	CESF-1.0	09330006205
CESM-1.5	09330006104	CESF-1.5	09330006204
CESM-2.5	09330006102	CESF-2.5	09330006202
CESM-3.0	09330006106	CESF-3.0	09330006206
CESM-4.0	09330006107	CESF-4.0	09330006207

公 Male	订货号 Part Number	母 Female	订货号 Part Number
CEGM-0.37	09330006117	CEGF-0.37	09330006217
CEGM-0.5	09330006122	CEGF-0.5	09330006222
CEGM-0.75	09330006115	CEGF-0.75	09330006215
CEGM-1.0	09330006118	CEGF-1.0	09330006218
CEGM-1.5	09330006116	CEGF-1.5	09330006216
CEGM-2.5	09330006123	CEGF-2.5	09330006223
CEGM-4.0	09330006119	CEGF-4.0	09330006221

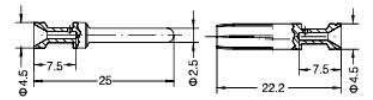

标示 Identification	线规 Wire gauge	剥线长度 Shipping length
no groove	0.14-0.37mm <sup>2</sup> AWG 26-22	7.5mm
no groove	0.5mm <sup>2</sup> AWG 20	7.5mm
1 groove	0.75mm <sup>2</sup> AWG 18	7.5mm
2 groove	1.5mm <sup>2</sup> AWG 16	7.5mm
3 groove	2.5mm <sup>2</sup> AWG 14	7.5mm
wide groove	3mm <sup>2</sup> AWG 12	7.5mm
no groove	4mm <sup>2</sup> AWG 12	7.5mm

压接线经 Wire gauge	型号 Type	订货号 Part Number
0.5-4mm <sup>2</sup>	TL02G	09990000021

适用类型 For	型号 Type	订货号 Part Number
16A 冷压针 16A Crimp contacts	TL01	09990000059

更多工具请参考 25-01~25-02页 More tools on P25-01-P25-02

# UTL-HD 系列 / HD SERIES

超高密度型连接器 / Ultra-high Density Connector

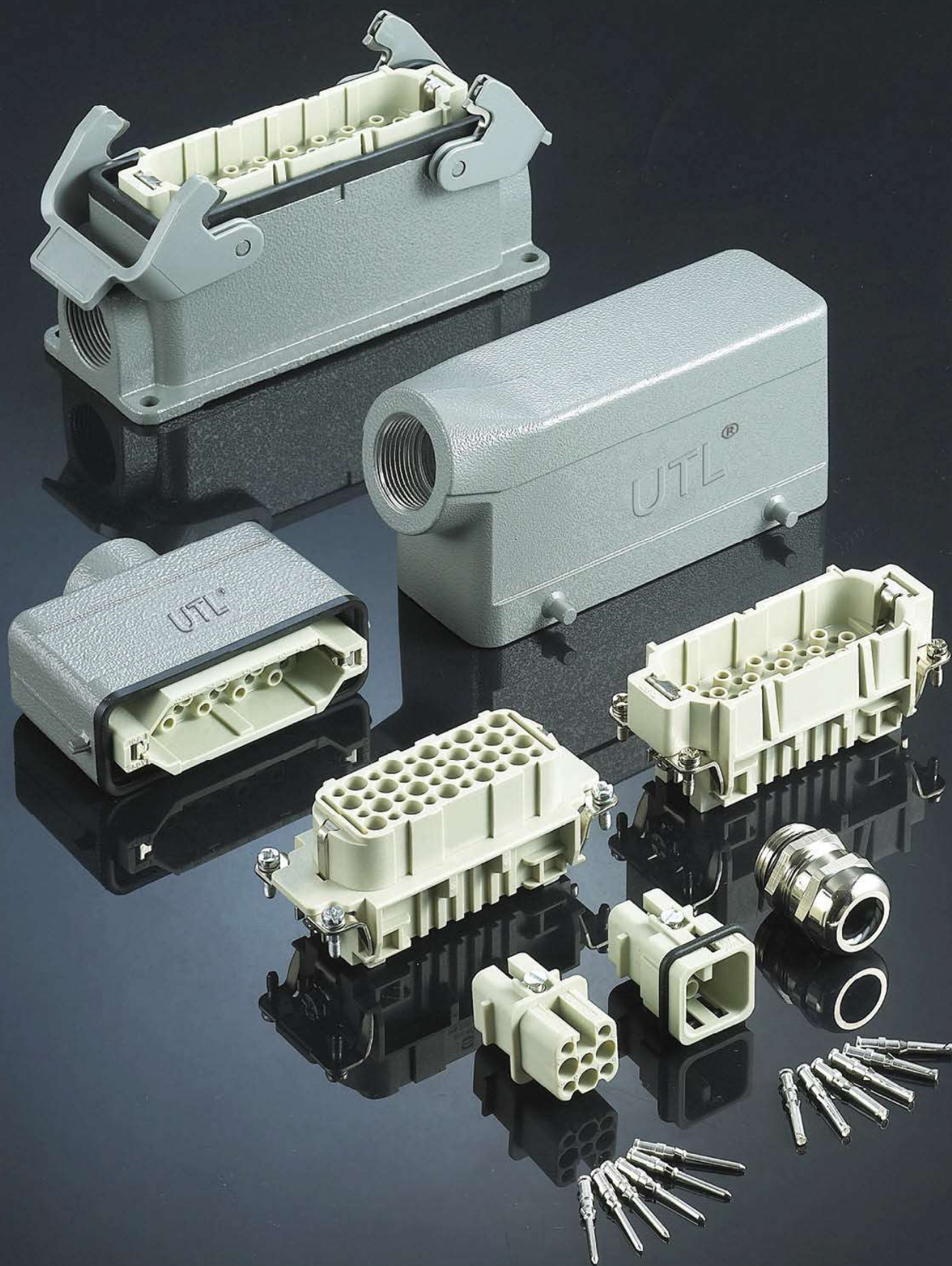

# Ultra-high Density Inserts

## UTL-HD 超高密度型插芯

### 技术参数 Technical Characteristics

规范	Specifications	
规范	Specifications	DIN EN 60 664
		DIN EN 61 984
插芯	Inserts	
依据 EN 61 984的额定电压	Electrical data acc. to EN 61 984	
接插件针数	Number Of Contacts	7,8,15,25,40,50(25X2),,64,80(40X2),128(64x2)+PE
额定电流	Rated Current	10A
额定电压	Rated Voltage	250V
额定脉冲电压	Rated Impulse Voltage	4kV
污染程度	Pollution Degree	3
污染等级2时的参数	Pollution Degree 2 Also	10A 230/400V 4kV 2
依据UL/CSA额定电压	Rated Voltage Acc.to UI CSA	600V
依据CSA绕线连接的额定电压	Rated Voltage For Wrap Terminal Acc. To CSA	2A 30V
HD-008的电气数据		
额定电流	Rated Current	10A
额定电压	Rated Voltage	-50V~120V
额定脉冲电压	Rated Impulse Voltage	4kV
污染程度	Pollution Degree	3
依据UL/CSA额定电压	Rated Voltage Acc.to UI CSA	50V
额定电压 (直流电压)	Rated Voltage	120V
绝缘电阻	Insulation Resistance	$\geq 10^{10} \Omega$
材料	Material	聚碳酸酯 Polycarbonate
工作温度范围	Limiting Temperatures	-40°C...+125°C
依据UL94阻燃等级	Flammability Acc. To UL94	V0
可拔插次数	Mechanical Working Life-mating Cycles	$\geq 500$
插针	Contacts	
材料	Material	铜合金 Copper Alloy
表面处理	Surface	镀金 Hard-gold Plated 镀银 Hard-silver Plated
接触电阻	Contact Resistance	$\leq 3m \Omega$
冷压连接	Screw Terminal	
导线规格	Wire Gauge	0.14-2.5mm <sup>2</sup>
AWG	AWG	26-14

### 电流负载能力 Current Carrying Capacity

电流负载能力所受的限制主要来自包含接插针的接插体可承受的最大温度

The current carrying is limited by maximum temperature of materials for Inserts and contacts including terminals.

测试和控制过程依据 Measuring and testing techniques according to DIN EN 60512-5

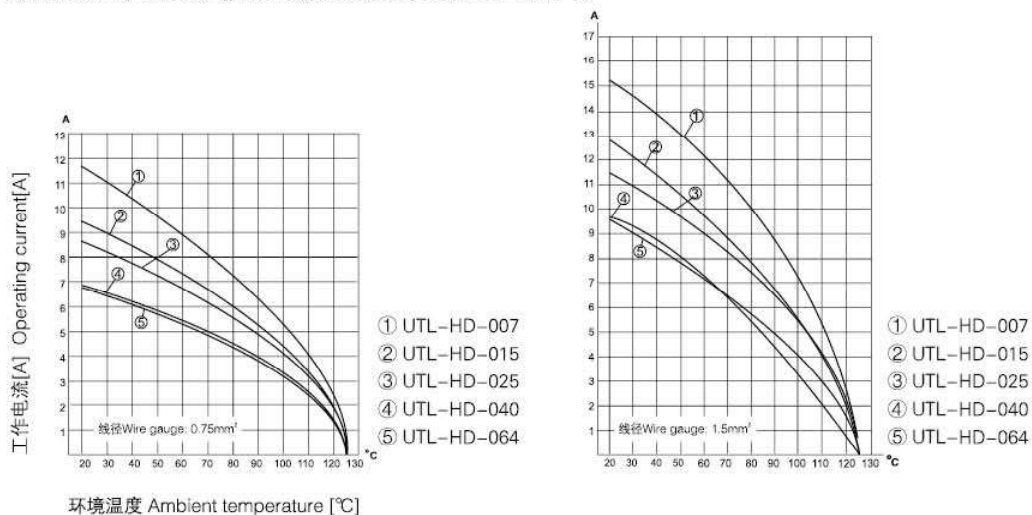

# Ultra-high Density Inserts

## UTL-HD 超高密度型插芯

### HD调整插针分布可提高工作电压至500V/ Modified contact arrangement up to 500V

HD接插体在装满插针时,在绝缘等级3(C)时,其工作电压可达到250V。但其插针分布经过调整,同样在绝缘等级3(C)时,其工作电压允许值可达到500V。  
 The connector series HD equipped with all contacts may be used for voltages up to 250V ~ pollution degree 3.A modified contact loading arrangement permits use up to 500V ~ pollution degree also in pollution degree C.

### 调整后插针分布 Contact arrangement view from termination side

10A 500V 6kV 3

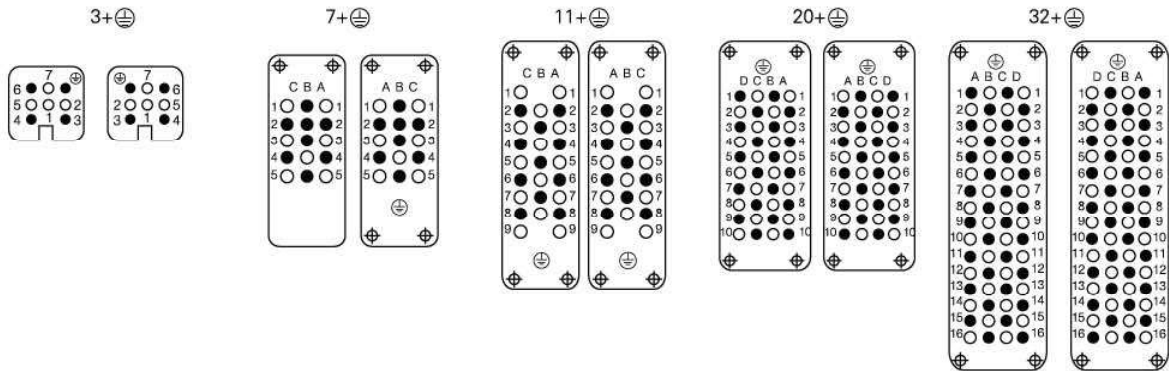

- 装有插针的插孔 Working contact      M 公接插体 Male insert
- 不装有插针的插孔 Without contact      F 母接插体 Female insert

# Ultra-high Density Inserts

## UTL-HD-007 超高密度型插芯 250V 10A 7+⊕

### 插芯 Inserts

外壳尺寸: 匹配3A外壳, 详情请参考11-05-11-11页

Hoods/Housings: Matching 3A Hood Housing, detail on P11-05-P11-

冷压连接 Crimp terminal



插芯 Inserts	型号 Type	订货号 Part Number
公 Male	UTL-HD-007-MC	09210073031
母 Female	UTL-HD-007-FC	09210073131

接插针排序  
Contacts arrangement vi  
from termination side

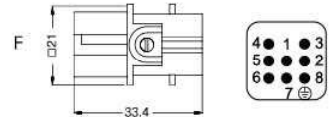
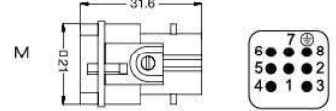

快速上锁 Quick lock



插芯 Inserts	型号 Type	订货号 Part Number
公 Male	UTL-HD-007-MQ	09210072632
母 Female	UTL-HD-007-FQ	09210072732

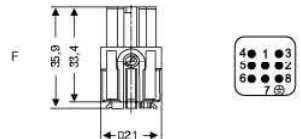
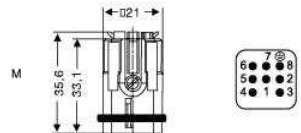

### 附件 Accessories

10A 冷压针 Crimp contacts

接触电阻 Contact resistance  $\leq 3m\Omega$   
镀银 Silver plated



公 Male	订货号 Part Number	母 Female	订货号 Part Number
CDSM-0.37	09150006104	CDSF-0.37	09150006204
CDSM-0.5	09150006103	CDSF-0.5	09150006203
CDSM-0.75	09150006105	CDSF-0.75	09150006205
CDSM-1.0	09150006102	CDSF-1.0	09150006202
CDSM-1.5	09150006101	CDSF-1.5	09150006201
CDSM-2.5	09150006106	CDSF-2.5	09150006206

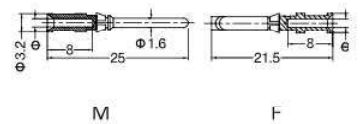

镀金 Gold plated



公 Male	订货号 Part Number	母 Female	订货号 Part Number
CDGM-0.37	09150006124	CDGF-0.37	09150006224
CDGM-0.5	09150006123	CDGF-0.5	09150006223
CDGM-0.75	09150006125	CDGF-0.75	09150006225
CDGM-1.0	09150006122	CDGF-1.0	09150006222
CDGM-1.5	09150006121	CDGF-1.5	09150006221
CDGM-2.5	09150006126	CDGF-2.5	09150006226

线规 Wire gauge	$\Phi$	剥线长度 Stripping length
0.14-0.37 mm <sup>2</sup>	AWG 26-22	8 mm
0.5 mm <sup>2</sup>	AWG 20	8 mm
0.75 mm <sup>2</sup>	AWG 18	8 mm
1 mm <sup>2</sup>	AWG 18	8 mm
1.5 mm <sup>2</sup>	AWG 16	8 mm
2.5 mm <sup>2</sup>	AWG 14	6 mm

工具 Tools

冷压钳 Crimping tool



压接线经 Wire gauge	型号 Type	订货号 Part Number
0.14-4mm <sup>2</sup>	TL02G	09990000021

退针器 Removal tool



适用类型 For	型号 Type	订货号 Part Number
10A 冷压针 10A Crimp contacts	TL00	09990000012

更多工具请参考 25-01~25-02页 More tools on P25-01~P25-02

# Ultra-high Density Inserts

## UTL-HD-015 超高密度型插芯 -120V~50V 10A 8+⊕

### 插芯 Inserts

外壳尺寸：匹配3A外壳，详情请参考11-05-11-11页

Hoods/Housings: Matching 3A Hood Housing, detail on P11-05~P11-11

冷压连接 Crimp terminal



插芯 Inserts	型号 Type	订货号 Part Number
公 Male	UTL-HD-008-MC	09360083001
母 Female	UTL-HD-008-FC	09360083101

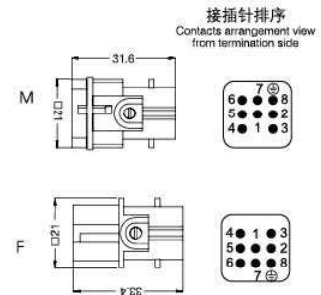

快速上锁 Quick lock



插芯 Inserts	型号 Type	订货号 Part Number
公 Male	UTL-HD-008-MQ	09360082632
母 Female	UTL-HD-008-FQ	09360082732

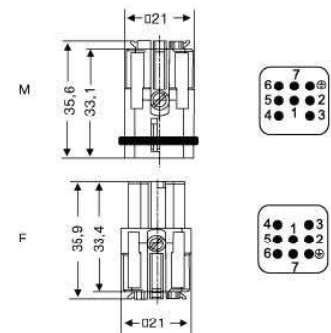

### 附件 Accessories

10A 冷压针 Crimp contacts

接触电阻 Contact resistance  $\leq 3m\Omega$   
镀银 Silver plated



公 Male	订货号 Part Number	母 Female	订货号 Part Number
CDSM-0.37	09150006104	CDSF-0.37	09150006204
CDSM-0.5	09150006103	CDSF-0.5	09150006203
CDSM-0.75	09150006105	CDSF-0.75	09150006205
CDSM-1.0	09150006102	CDSF-1.0	09150006202
CDSM-1.5	09150006101	CDSF-1.5	09150006201
CDSM-2.5	09150006106	CDSF-2.5	09150006206

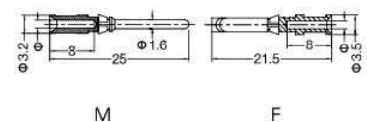

镀金 Gold plated



公 Male	订货号 Part Number	母 Female	订货号 Part Number
CDGM-0.37	09150006124	CDGF-0.37	09150006224
CDGM-0.5	09150006123	CDGF-0.5	09150006223
CDGM-0.75	09150006125	CDGF-0.75	09150006225
CDGM-1.0	09150006122	CDGF-1.0	09150006222
CDGM-1.5	09150006121	CDGF-1.5	09150006221
CDGM-2.5	09150006126	CDGF-2.5	09150006226

线规 Wire gauge	$\phi$	剥线长度 Stripping length
0.14-0.37 mm <sup>2</sup> AWG 26-22	0.9	8 mm
0.5 mm <sup>2</sup> AWG 20	1.1	8 mm
0.75 mm <sup>2</sup> AWG 18	1.3	8 mm
1 mm <sup>2</sup> AWG 18	1.45	8 mm
1.5 mm <sup>2</sup> AWG 16	1.75	8 mm
2.5 mm <sup>2</sup> AWG 14	2.25	6 mm

工具 Tools

冷压钳 Crimping tool



压接线经 Wire gauge	型号 Type	订货号 Part Number
0.14-4mm <sup>2</sup>	TL02G	09990000021

退针器 Removal tool



适用类型 For	型号 Type	订货号 Part Number
10A 冷压针	TL00	09990000012
10A Crimp contacts		

更多工具请参考 25-01~25-02页 More tools on P25-01~P25-02

# Ultra-high Density Inserts

## UTL-HD-015 超高密度型插芯 250V 10A 15+⊕

### 插芯 Inserts

外壳尺寸: 匹配10A外壳, 详情请参12-01-12-02页

Hoods/Housings: Matching 10A Hood Housing, detail on P12-01~P12-02

冷压连接 Crimp terminal



插芯 Inserts	型号 Type	订货号 Part Number
公 Male	UTL-HD-015-MC	09210153001
母 Female	UTL-HD-015-FC	09210153101

接插体之间的最大距离24mm  
Distance for contact max.24mm

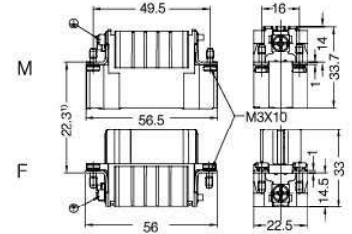

接插针排序

Contacts arrangement view from termination side

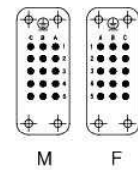

面板安装开孔图

Panel cut out for inserts for use without Hoods/housings

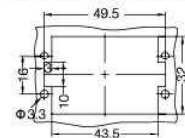

### 附件 Accessories

10A 冷压针 Crimp contacts

接触电阻 Contact resistance  $\leq 3m\Omega$   
镀银 Silver plated



公 Male	订货号 Part Number	母 Female	订货号 Part Number
CDSM-0.37	09150006104	CDSF-0.37	09150006204
CDSM-0.5	09150006103	CDSF-0.5	09150006203
CDSM-0.75	09150006105	CDSF-0.75	09150006205
CDSM-1.0	09150006102	CDSF-1.0	09150006202
CDSM-1.5	09150006101	CDSF-1.5	09150006201
CDSM-2.5	09150006106	CDSF-2.5	09150006206

镀金 Gold plated



公 Male	订货号 Part Number	母 Female	订货号 Part Number
CDGM-0.37	09150006124	CDGF-0.37	09150006224
CDGM-0.5	09150006123	CDGF-0.5	09150006223
CDGM-0.75	09150006125	CDGF-0.75	09150006225
CDGM-1.0	09150006122	CDGF-1.0	09150006222
CDGM-1.5	09150006121	CDGF-1.5	09150006221
CDGM-2.5	09150006126	CDGF-2.5	09150006226

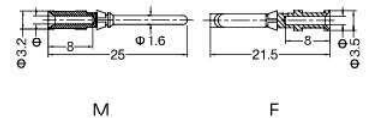

线规 Wire gauge	$\Phi$	剥线长度 Stripping length
0.14-0.37 mm <sup>2</sup>	AWG 26-22	0.9 8 mm
0.5 mm <sup>2</sup>	AWG 20	1.1 8 mm
0.75 mm <sup>2</sup>	AWG 18	1.3 8 mm
1 mm <sup>2</sup>	AWG 18	1.45 8 mm
1.5 mm <sup>2</sup>	AWG 16	1.75 8 mm
2.5 mm <sup>2</sup>	AWG 14	2.25 6 mm

工具 Tools

冷压钳 Crimping tool



退针器 Removal tool



压接线经 Wire gauge	型号 Type	订货号 Part Number
0.14-4mm <sup>2</sup>	TL02G	09990000021

适用类型 For	型号 Type	订货号 Part Number
10A 冷压针	TL00	09990000012
10A Crimp contacts		

更多工具请参考 25-01-25-02页 More tools on P25-01~P25-02

# Ultra-high Density Inserts

## UTL-HD-025 超高密度型插芯 250V 10A 25+⊕

### 插芯 Inserts

外壳尺寸: 匹配16A外壳, 详情请参考13-01~13-02页

Hoods/Housings: Matching 16A Hood Housing, detail on P13-01~P13-02

冷压连接 Crimp terminal



插芯 Inserts	型号 Type	订货号 Part Number
公 Male	UTL-HD-025-MC	09210253001
母 Female	UTL-HD-025-FC	09210253101

接插体之间的最大距离24mm  
Distance for contact max.24mm

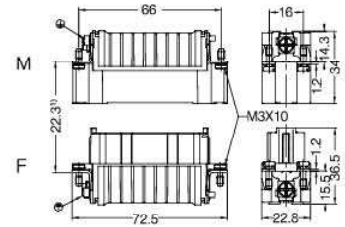

接插针排序

Contacts arrangement view from termination side

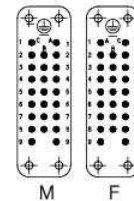

面板安装开孔图

Panel cut out for inserts for use without Hoods/housings

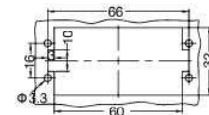

### 附件 Accessories

10A 冷压针 Crimp contacts

接触电阻 Contact resistance  $\leq 3m\Omega$   
镀银 Silver plated



镀金 Gold plated



工具 Tools

冷压钳 Crimping tool



退针器 Removal tool



公 Male	订货号 Part Number	母 Female	订货号 Part Number
CDSM-0.37	09150006104	CDSF-0.37	09150006204
CDSM-0.5	09150006103	CDSF-0.5	09150006203
CDSM-0.75	09150006105	CDSF-0.75	09150006205
CDSM-1.0	09150006102	CDSF-1.0	09150006202
CDSM-1.5	09150006101	CDSF-1.5	09150006201
CDSM-2.5	09150006106	CDSF-2.5	09150006206

公 Male	订货号 Part Number	母 Female	订货号 Part Number
CDGM-0.37	09150006124	CDGF-0.37	09150006224
CDGM-0.5	09150006123	CDGF-0.5	09150006223
CDGM-0.75	09150006125	CDGF-0.75	09150006225
CDGM-1.0	09150006122	CDGF-1.0	09150006222
CDGM-1.5	09150006121	CDGF-1.5	09150006221
CDGM-2.5	09150006126	CDGF-2.5	09150006226

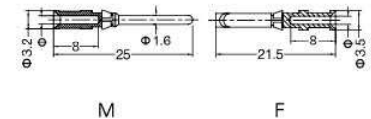

线规 Wire gauge	Φ	剥线长度 Stripping length
0.14-0.37 mm <sup>2</sup> AWG 26-22	0.9	8 mm
0.5 mm <sup>2</sup> AWG 20	1.1	8 mm
0.75 mm <sup>2</sup> AWG 18	1.3	8 mm
1 mm <sup>2</sup> AWG 18	1.45	8 mm
1.5 mm <sup>2</sup> AWG 16	1.75	8 mm
2.5 mm <sup>2</sup> AWG 14	2.25	6 mm

压接线径 Wire gauge	型号 Type	订货号 Part Number
0.14-4mm <sup>2</sup>	TL02G	09990000021

适用类型 For	型号 Type	订货号 Part Number
10A 冷压针	TL00	09990000012
10A Crimp contacts		

更多工具请参考 25-01~25-02页 More tools on P25-01~P25-02



# Ultra-high Density Inserts

## UTL-HD-040 超高密度型插芯 250V 10A 40+⊕

### 插芯 Inserts

外壳尺寸: 匹配16B外壳, 详情请参考17-01-17-21页

Hoods/Housings: Matching 16B Hood Housing, detail on P17-01~P17-21

冷压连接 Crimp terminal



插芯 Inserts	型号 Type	订货号 Part Number
公 Male	UTL-HD-040-MC	09210403001
母 Female	UTL-HD-040-FC	09210403101

接插体之间的最大距离24mm  
Distance for contact max.24mm

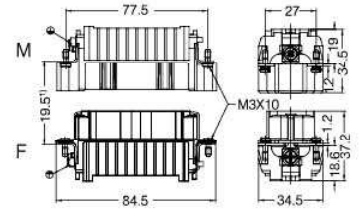

接插针排序

Contacts arrangement view from termination side

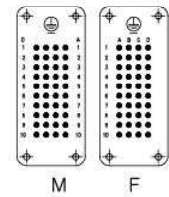

面板安装开孔图

Panel cut out for inserts for use without Hoods/housings

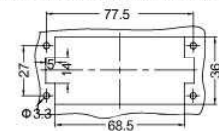

### 附件 Accessories

10A 冷压针 Crimp contacts

接触电阻 Contact resistance  $\leq 3m\Omega$

镀银 Silver plated



公 Male	订货号 Part Number	母 Female	订货号 Part Number
CDSM-0.37	09150006104	CDSF-0.37	09150006204
CDSM-0.5	09150006103	CDSF-0.5	09150006203
CDSM-0.75	09150006105	CDSF-0.75	09150006205
CDSM-1.0	09150006102	CDSF-1.0	09150006202
CDSM-1.5	09150006101	CDSF-1.5	09150006201
CDSM-2.5	09150006106	CDSF-2.5	09150006206

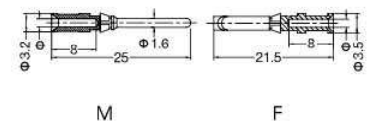

镀金 Gold plated



公 Male	订货号 Part Number	母 Female	订货号 Part Number
CDGM-0.37	09150006124	CDGF-0.37	09150006224
CDGM-0.5	09150006123	CDGF-0.5	09150006223
CDGM-0.75	09150006125	CDGF-0.75	09150006225
CDGM-1.0	09150006122	CDGF-1.0	09150006222
CDGM-1.5	09150006121	CDGF-1.5	09150006221
CDGM-2.5	09150006126	CDGF-2.5	09150006226

线规 Wire gauge	$\Phi$	剥线长度 Stripping length
0.14-0.37 mm <sup>2</sup>	AWG 26-22	0.9
0.5 mm <sup>2</sup>	AWG 20	1.1
0.75 mm <sup>2</sup>	AWG 18	1.3
1 mm <sup>2</sup>	AWG 18	1.45
1.5 mm <sup>2</sup>	AWG 16	1.75
2.5 mm <sup>2</sup>	AWG 14	2.25

工具 Tools

冷压钳 Crimping tool



退针器 Removal tool



压接线经 Wire gauge	型号 Type	订货号 Part Number
0.14-4mm <sup>2</sup>	TL02G	09990000021

适用类型 For	型号 Type	订货号 Part Number
10A 冷压针	TL00	09990000012
10A Crimp contacts		

更多工具请参考 25-01~25-02页 More tools on P25-01~P25-02

# Ultra-high Density Inserts

## UTL-HD-050 超高密度型插芯 250V 10A 50+ $\oplus$

### 插芯 Inserts

外壳尺寸：匹配32A外壳，详情请参考14-01~14-02页

Hoods/Housings: Matching 32A Hood Housing, detail on P14-01~P14-02

冷压连接 Crimp terminal



	型号 Type	订货号 Part Number
公 Male	UTL-HD-025-MC(1-25)	09210253001
	UTL-HD-025-MC(1-25)	09210253001
母 Female	UTL-HD-025-FC(1-25)	09210253101
	UTL-HD-025-FC(1-25)	09210253101

接插体之间的最大距离24mm  
Distance for contact max.24mm

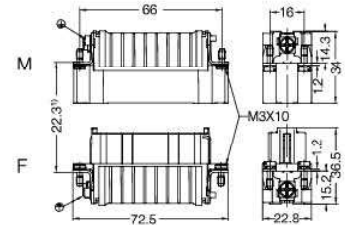

接插针排序

Contacts arrangement view from termination side

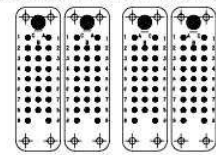

面板安装开孔图

Panel cut out for inserts for use without Hooda/housings

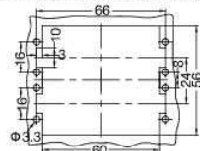

### 附件 Accessories

10A 冷压针 Crimp contacts

接触电阻 Contact resistance  $\leq 3m\Omega$   
镀银 Silver plated



公 Male	订货号 Part Number	母 Female	订货号 Part Number
CDSM-0.37	09150006104	CDSF-0.37	09150006204
CDSM-0.5	09150006103	CDSF-0.5	09150006203
CDSM-0.75	09150006105	CDSF-0.75	09150006205
CDSM-1.0	09150006102	CDSF-1.0	09150006202
CDSM-1.5	09150006101	CDSF-1.5	09150006201
CDSM-2.5	09150006106	CDSF-2.5	09150006206

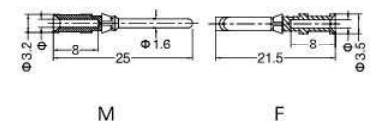

镀金 Gold plated



公 Male	订货号 Part Number	母 Female	订货号 Part Number
CDGM-0.37	09150006124	CDGF-0.37	09150006224
CDGM-0.5	09150006123	CDGF-0.5	09150006223
CDGM-0.75	09150006125	CDGF-0.75	09150006225
CDGM-1.0	09150006122	CDGF-1.0	09150006222
CDGM-1.5	09150006121	CDGF-1.5	09150006221
CDGM-2.5	09150006126	CDGF-2.5	09150006226

工具 Tools

冷压钳 Crimping tool



退针器 Removal tool



压接线径 Wire gauge	型号 Type	订货号 Part Number
0.14-4mm <sup>2</sup>	TL02G	09990000021

适用类型 For	型号 Type	订货号 Part Number
10A 冷压针	TL00	09990000012
10A Crimp contacts		

更多工具请参考 25-01~25-02页 More tools on P25-01~P25-02

线规 Wire gauge	$\Phi$	剥线长度 Stripping length
0.14-0.37 mm <sup>2</sup>	AWG 26-22	0.9
0.5 mm <sup>2</sup>	AWG 20	1.1
0.75 mm <sup>2</sup>	AWG 18	1.3
1 mm <sup>2</sup>	AWG 18	1.45
1.5 mm <sup>2</sup>	AWG 16	1.75
2.5 mm <sup>2</sup>	AWG 14	2.25

# Ultra-high Density Inserts

## UTL-HD-064 超高密度型插芯 250V 10A 64+⊕

### 插芯 Inserts

外壳尺寸：匹配24B外壳，详情请参考18-01~18-22页

Hoods/Housings: Matching 24B Hood Housing, detail on P18-01~P18-22

冷压连接 Crimp terminal



插芯 Inserts	型号 Type	订货号 Part Number
公 Male	UTL-HD-064-MC	09210643001
母 Female	UTL-HD-064-FC	09210643101

接插体之间的最大距离24mm  
Distance for contact max.24mm

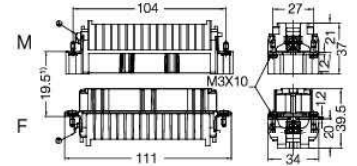

接插针排序

Contacts arrangement view from termination side

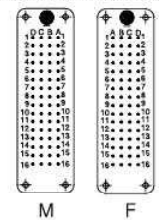

面板安装开孔图

Panel cut out for inserts for use without Hoods/housings

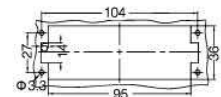

### 附件 Accessories

10A 冷压针 Crimp contacts

接触电阻 Contact resistance  $\leq 3m\Omega$   
镀银 Silver plated



公 Male	订货号 Part Number	母 Female	订货号 Part Number
CDSM-0.37	09150006104	CDSF-0.37	09150006204
CDSM-0.5	09150006103	CDSF-0.5	09150006203
CDSM-0.75	09150006105	CDSF-0.75	09150006205
CDSM-1.0	09150006102	CDSF-1.0	09150006202
CDSM-1.5	09150006101	CDSF-1.5	09150006201
CDSM-2.5	09150006106	CDSF-2.5	09150006206

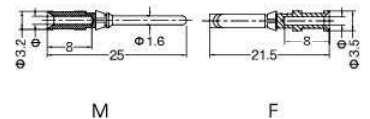

镀金 Gold plated



公 Male	订货号 Part Number	母 Female	订货号 Part Number
CDGM-0.37	09150006124	CDGF-0.37	09150006224
CDGM-0.5	09150006123	CDGF-0.5	09150006223
CDGM-0.75	09150006125	CDGF-0.75	09150006225
CDGM-1.0	09150006122	CDGF-1.0	09150006222
CDGM-1.5	09150006121	CDGF-1.5	09150006221
CDGM-2.5	09150006126	CDGF-2.5	09150006226

线规 Wire gauge	Φ	剥线长度 Stripping length
0.14-0.37 mm <sup>2</sup>	AWG 26-22	0.9
0.5 mm <sup>2</sup>	AWG 20	1.1
0.75 mm <sup>2</sup>	AWG 18	1.3
1 mm <sup>2</sup>	AWG 18	1.45
1.5 mm <sup>2</sup>	AWG 16	1.75
2.5 mm <sup>2</sup>	AWG 14	2.25

工具 Tools

冷压钳 Crimping tool



退针器 Removal tool



压接线经 Wire gauge	型号 Type	订货号 Part Number
0.14-4mm <sup>2</sup>	TL02G	09990000021

适用类型 For	型号 Type	订货号 Part Number
10A 冷压针	TL00	09990000012
10A Crimp contacts		

更多工具请参考 25-01~25-02页 More tools on P25-01~P25-02

# Ultra-high Density Inserts

## UTL-HD-080 超高密度型插芯 250V 10A 80+ $\oplus$

### 插芯 Inserts

外壳尺寸: 匹配32B外壳, 详情请参考19-01~19-04页

Hoods/Housings: Matching 32B Hood Housing, detail on P19-01~P19-04

冷压连接 Crimp terminal



插芯 Inserts	型号 Type	订货号 Part Number
公 Male	UTL-HD-040-MC(1-40)	09210403001
	UTL-HD-040-MC(1-40)	09210403001
母 Female	UTL-HD-040-FC(1-40)	09210403101
	UTL-HD-040-FC(1-40)	09210403101

接插体之间的最大距离24mm  
Distance for contact max.24mm

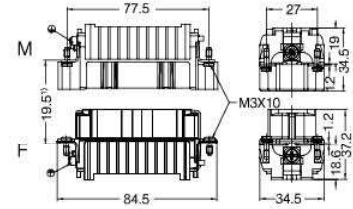

接插针排序

Contacts arrangement view from termination side

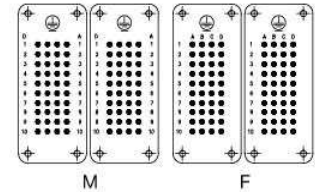

面板安装开孔图

Panel cut out for use without Hoods/housings

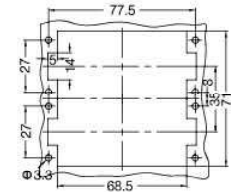

### 附件 Accessories

10A 冷压针 Crimp contacts

接触电阻 Contact resistance  $\leq 3m\Omega$   
镀银 Silver plated



公 Male	订货号 Part Number	母 Female	订货号 Part Number
CDSM-0.37	09150006104	CDSF-0.37	09150006204
CDSM-0.5	09150006103	CDSF-0.5	09150006203
CDSM-0.75	09150006105	CDSF-0.75	09150006205
CDSM-1.0	09150006102	CDSF-1.0	09150006202
CDSM-1.5	09150006101	CDSF-1.5	09150006201
CDSM-2.5	09150006106	CDSF-2.5	09150006206

镀金 Gold plated



公 Male	订货号 Part Number	母 Female	订货号 Part Number
CDGM-0.37	09150006124	CDGF-0.37	09150006224
CDGM-0.5	09150006123	CDGF-0.5	09150006223
CDGM-0.75	09150006125	CDGF-0.75	09150006225
CDGM-1.0	09150006122	CDGF-1.0	09150006222
CDGM-1.5	09150006121	CDGF-1.5	09150006221
CDGM-2.5	09150006126	CDGF-2.5	09150006226

工具 Tools

冷压钳 Crimping tool



退针器 Removal tool



压接线径 Wire gauge	型号 Type	订货号 Part Number
0.14-4mm <sup>2</sup>	TL02G	09990000021

适用类型 For	型号 Type	订货号 Part Number
10A 冷压针	TL00	09990000012
10A Crimp contacts		

更多工具请参考 25-01~25-02页 More tools on P25-01~P25-02

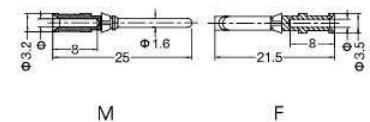

线规 Wire gauge	$\Phi$	剥线长度 Stripping length
0.14-0.37 mm <sup>2</sup> AWG 26-22	0.9	8 mm
0.5 mm <sup>2</sup> AWG 20	1.1	8 mm
0.75 mm <sup>2</sup> AWG 18	1.3	8 mm
1 mm <sup>2</sup> AWG 18	1.45	8 mm
1.5 mm <sup>2</sup> AWG 16	1.75	8 mm
2.5 mm <sup>2</sup> AWG 14	2.25	6 mm

# Ultra-high Density Inserts

## UTL-HD-128 超高密度型插芯 250V 10A 128+⊕

### 插芯 Inserts

外壳尺寸: 匹配48B外壳, 详情请参考20-01~20-02页

Hoods/Housings: Matching 48B Hood Housing, detail on P20-01~P20-02

冷压连接 Crimp terminal



插芯 Inserts	型号 Type	订货号 Part Number
公 Male	UTL-HD-064-MC(1-64)	09210643001
	UTL-HD-064-MC(1-64)	09210643001
母 Female	UTL-HD-064-FC(1-64)	09210643101
	UTL-HD-064-FC(1-64)	09210643101

接插体之间的最大距离24mm  
Distance for contact max.24mm

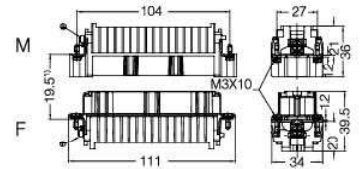

接插针排序

Contacts arrangement view from termination side

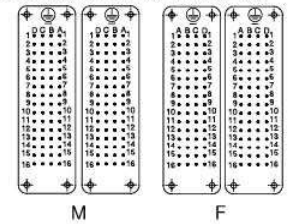

面板安装开孔图

Panel cut out for inserts for use without Hoods/housings

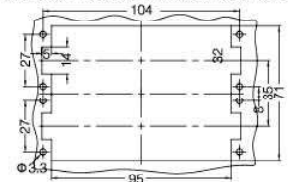

### 附件 Accessories

10A 冷压针 Crimp contacts

接触电阻 Contact resistance  $\leq 3m\Omega$   
镀银 Silver plated



公 Male	订货号 Part Number	母 Female	订货号 Part Number
CDSM-0.37	09150006104	CDSF-0.37	09150006204
CDSM-0.5	09150006103	CDSF-0.5	09150006203
CDSM-0.75	09150006105	CDSF-0.75	09150006205
CDSM-1.0	09150006102	CDSF-1.0	09150006202
CDSM-1.5	09150006101	CDSF-1.5	09150006201
CDSM-2.5	09150006106	CDSF-2.5	09150006206

镀金 Gold plated



公 Male	订货号 Part Number	母 Female	订货号 Part Number
CDGM-0.37	09150006124	CDGF-0.37	09150006224
CDGM-0.5	09150006123	CDGF-0.5	09150006223
CDGM-0.75	09150006125	CDGF-0.75	09150006225
CDGM-1.0	09150006122	CDGF-1.0	09150006222
CDGM-1.5	09150006121	CDGF-1.5	09150006221
CDGM-2.5	09150006126	CDGF-2.5	09150006226

工具 Tools

冷压钳 Crimping tool



退针器 Removal tool



压接线径 Wire gauge	型号 Type	订货号 Part Number
0.14-4mm <sup>2</sup>	TL02G	09990000021

适用类型 For	型号 Type	订货号 Part Number
10A 冷压针	TL00	09990000012
10A Crimp contacts		

更多工具请参考 25-01~25-02页 More tools on P25-01~P25-02

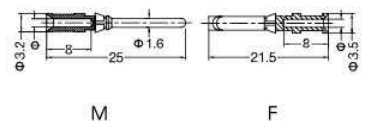

线径 Wire gauge	Φ	剥线长度 Stripping length
0.14-0.37 mm <sup>2</sup>	AWG 26-22	0.9 8 mm
0.5 mm <sup>2</sup>	AWG 20	1.1 8 mm
0.75 mm <sup>2</sup>	AWG 18	1.3 8 mm
1 mm <sup>2</sup>	AWG 18	1.45 8 mm
1.5 mm <sup>2</sup>	AWG 16	1.75 8 mm
2.5 mm <sup>2</sup>	AWG 14	2.25 6 mm

# UTL-HDD 系列 / HDD SERIES

超高密度型连接器 / Ultra-high Density Connector

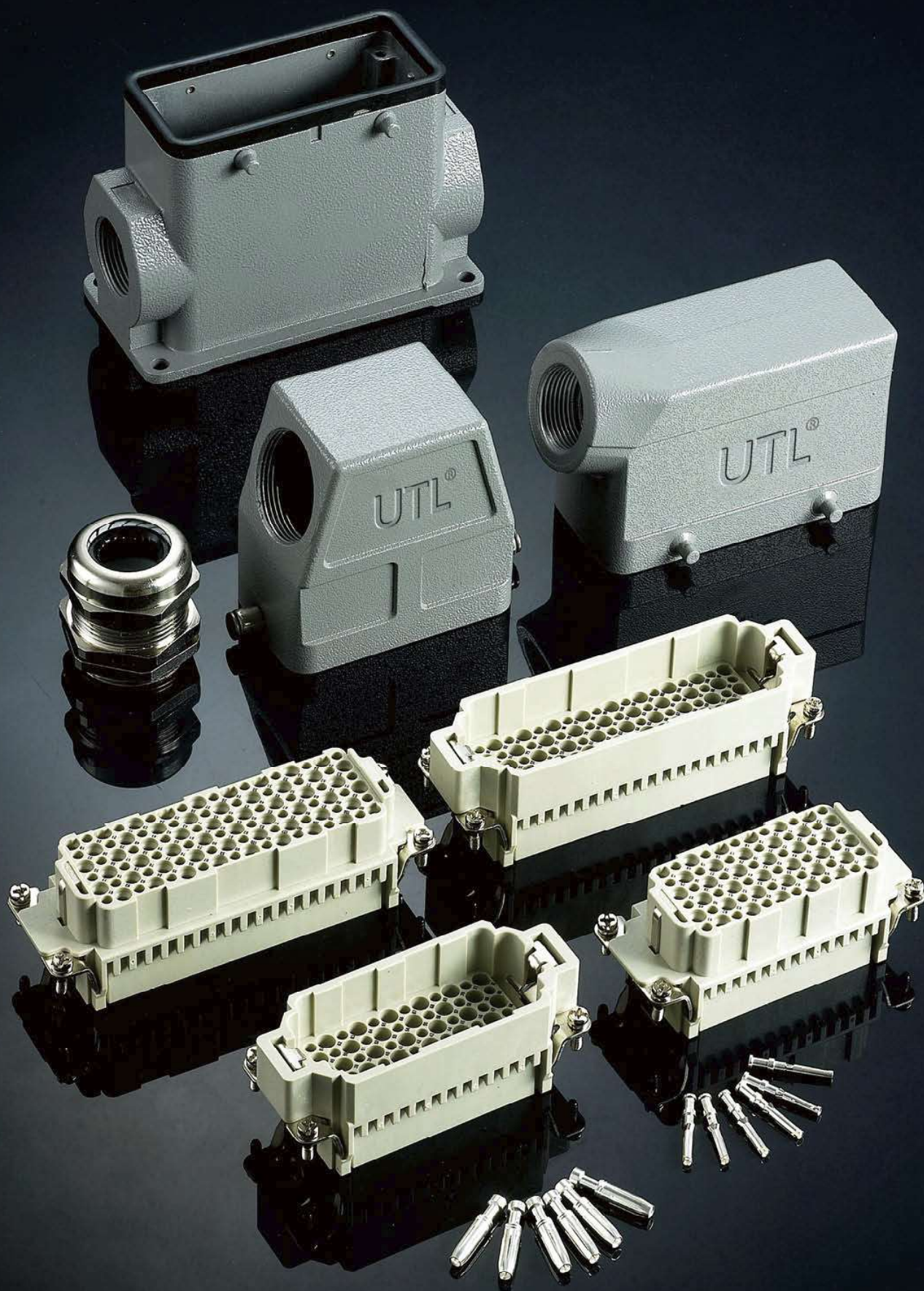

# Ultra-high Density Inserts

## UTL-HDD 超高密度型插芯

### 技术参数 Technical Characteristics

规范	Specifications	
规范	Specifications	DIN EN 60 664
		DIN EN 61 984
插芯	Inserts	
依据 EN 61 984的额定电压	Electrical Data Acc. To EN 61 984	
接插件针数	Number Of Contacts	24,42,72,108,144(72X2),216(108X2)+PE
额定电流	Rated Current	10A
额定电压	Rated Voltage	250V
额定脉冲电压	Rated Impulse Voltage	4kV
污染程度	Pollution Degree	3
污染等级2时的参数	Pollution Degree 2 Also	10A 230/400V 4kV 2
依据UL/CSA额定电压	Rated Voltage Acc.to UI CSA	600V
绝缘电阻	Insulation Resistance	$\geq 10^{10} \Omega$
材料	Material	聚碳酸酯 Polycarbonate
工作温度范围	Limiting Temperatures	-40°C...+125°C
依据UL94阻燃等级	Flammability Acc. To UL94	V0
可拔插次数	Mechanical Working Life-mating Cycles	$\geq 500$
插针	Contacts	
材料	Material	铜合金 Copper Alloy
表面处理	Surface	镀金 Hard-gold Plated 镀银 Hard-silver Plated
接触电阻	Contact Resistance	$\leq 3m\Omega$
螺钉连接	Screw Terminal	
导线规格	Wire Gauge	0.14-2.5mm <sup>2</sup>
AWG	AWG	26-14

### 电流负载能力 Current Carrying Capacity

电流负载能力所受的限制主要来自包含接插针的接插体可承受的最大温度

The current carrying is limited by maximum temperature of materials for Inserts and contacts including terminals.

测试和控制过程依据 Measuring and testing techniques according to DIN EN 60512-5

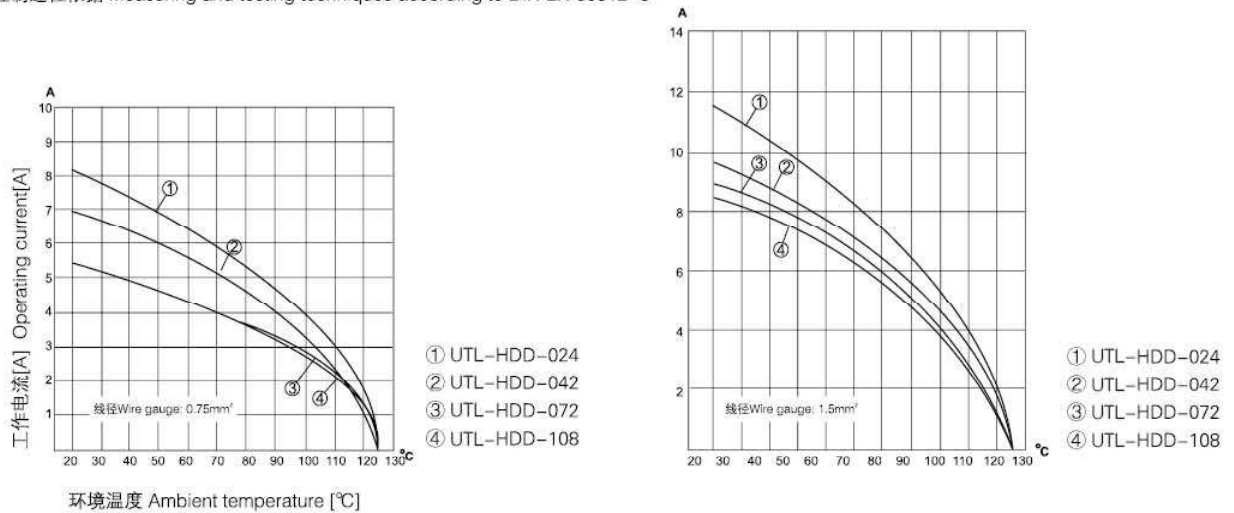

# Ultra-high Density Inserts

## UTL-HDD 超高密度型插芯

### UTL-HDD调整插针分布可提高工作电压至500V/Modified contact arrangement up to 500V

UTL-HD接插体在装满插针时,在绝缘等级3(C)时,其工作电压可达到250V。但其插针分布经过调整,同样在绝缘等级3(C)时,其工作电压允许值可达到500V。

The connector series HDD equipped with all contacts may be used for voltages up to 250V ~ pollution degree 3.A modified contact loading arrangement permits use up to 500V ~ pollution degree also in pollution degree C.

### 调整后插针分布 Contact arrangement view from termination side

10A 400V 6kV 3

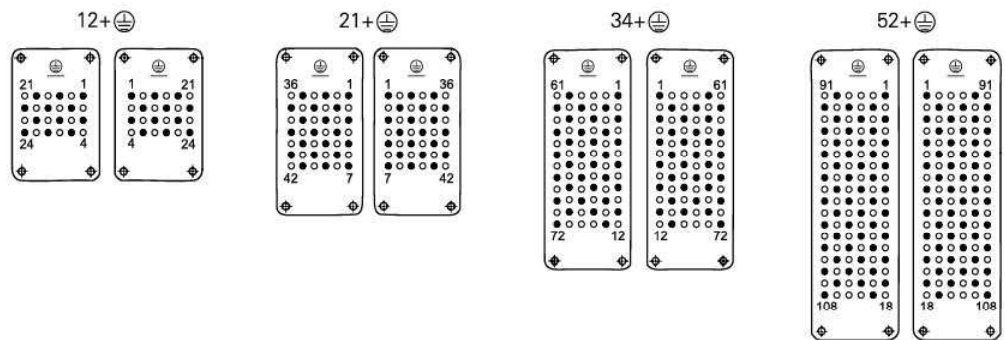

10A 500V 6kV 3

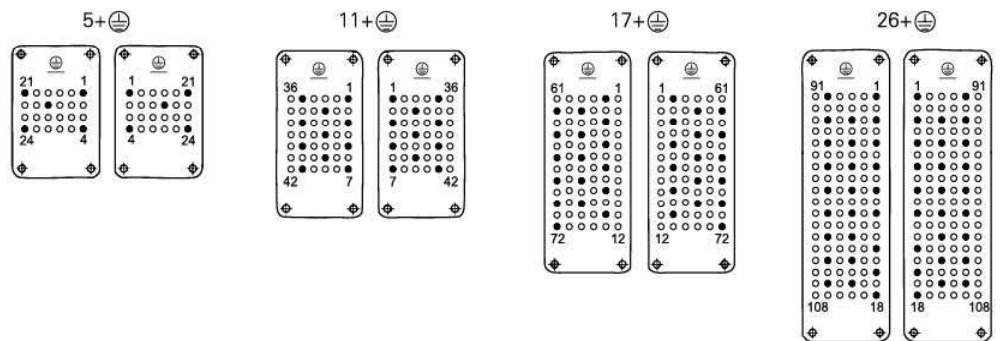

- 装有插针的插孔 Working contact      M 公接插体 Male insert
- 不装有插针的插孔 Without contact      F 母接插体 Female insert



# Ultra-high Density Inserts

## UTL-HDD-024 超高密度型插芯 250V 10A 24+⊕

### 插芯 Inserts

外壳尺寸: 匹配6B外壳, 详情请参考15-01~15-10页

Hoods/Housings: Matching 6B Hood Housing, detail on P15-01~P15-10

冷压连接 Crimp terminal



插芯 Inserts	型号 Type	订货号 Part Number
公 Male	UTL-HDD-024-MC	09160243001
母 Female	UTL-HDD-024-FC	09160243101

接插体之间的最大距离21mm  
Distance for contact max.21mm

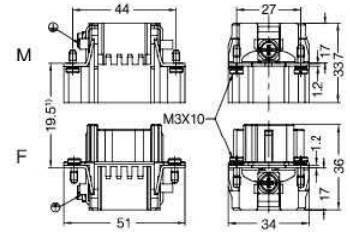

接插针排序

Contacts arrangement view from termination side

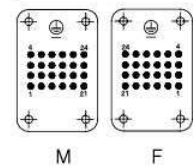

面板安装开孔图

Panel cut out for inserts for use without Hoods/housings

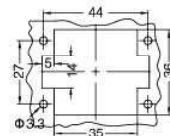

### 附件 Accessories

10A 冷压针 Crimp contacts

接触电阻 Contact resistance  $\leq 3m\Omega$   
镀银 Silver plated



公 Male	订货号 Part Number	母 Female	订货号 Part Number
CDSM-0.37	09150006104	CDSF-0.37	09150006204
CDSM-0.5	09150006103	CDSF-0.5	09150006203
CDSM-0.75	09150006105	CDSF-0.75	09150006205
CDSM-1.0	09150006102	CDSF-1.0	09150006202
CDSM-1.5	09150006101	CDSF-1.5	09150006201
CDSM-2.5	09150006106	CDSF-2.5	09150006206

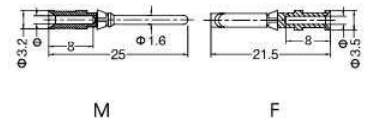

镀金 Gold plated



公 Male	订货号 Part Number	母 Female	订货号 Part Number
CDGM-0.37	09150006124	CDGF-0.37	09150006224
CDGM-0.5	09150006123	CDGF-0.5	09150006223
CDGM-0.75	09150006125	CDGF-0.75	09150006225
CDGM-1.0	09150006122	CDGF-1.0	09150006222
CDGM-1.5	09150006121	CDGF-1.5	09150006221
CDGM-2.5	09150006126	CDGF-2.5	09150006226

线规 Wire gauge	Φ	剥线长度 Stripping length
0.14-0.37 mm <sup>2</sup>	AWG 26-22	0.9 8 mm
0.5 mm <sup>2</sup>	AWG 20	1.1 8 mm
0.75 mm <sup>2</sup>	AWG 18	1.3 8 mm
1 mm <sup>2</sup>	AWG 18	1.45 8 mm
1.5 mm <sup>2</sup>	AWG 16	1.75 8 mm
2.5 mm <sup>2</sup>	AWG 14	2.25 8 mm

工具 Tools

冷压钳 Crimping tool



退针器 Removal tool



压接线经 Wire gauge	型号 Type	订货号 Part Number
0.14-4mm <sup>2</sup>	TL02G	09990000021

适用类型 For	型号 Type	订货号 Part Number
10A 冷压针	TL00	09990000012
10A Crimp contacts		

更多工具请参考 25-01~25-02页 More tools on P25-01~P25-02

# Ultra-high Density Inserts

## UTL-HDD-042 超高密度型插芯 250V 10A 42+⊖

### 插芯 Inserts

外壳尺寸: 匹配10B外壳, 详情请参考16-01 16-13页

Hoods/Housings: Matching 10B Hood Housing, detail on P16-01~P16-13

冷压连接 Crimp terminal



插芯 Inserts	型号 Type	订货号 Part Number
公 Male	UTL-HDD-042-MC	09160423001
母 Female	UTL-HDD-042-FC	09160423101

接插体之间的最大距离21mm  
Distance for contact max.21mm

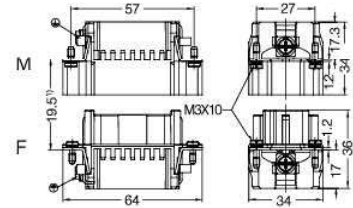

接插针排序

Contacts arrangement view from termination side

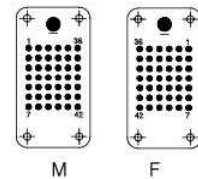

面板安装开孔图

Panel cut out for inserts for use without Hoods/housings

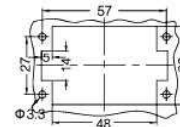

### 附件 Accessories

10A 冷压针 Crimp contacts

接触电阻 Contact resistance  $\leq 3m\Omega$   
镀银 Silver plated



公 Male	订货号 Part Number	母 Female	订货号 Part Number
CDSM-0.37	09150006104	CDSF-0.37	09150006204
CDSM-0.5	09150006103	CDSF-0.5	09150006203
CDSM-0.75	09150006105	CDSF-0.75	09150006205
CDSM-1.0	09150006102	CDSF-1.0	09150006202
CDSM-1.5	09150006101	CDSF-1.5	09150006201
CDSM-2.5	09150006106	CDSF-2.5	09150006206

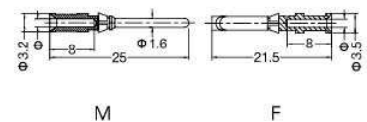

镀金 Gold plated



公 Male	订货号 Part Number	母 Female	订货号 Part Number
CDGM-0.37	09150006124	CDGF-0.37	09150006224
CDGM-0.5	09150006123	CDGF-0.5	09150006223
CDGM-0.75	09150006125	CDGF-0.75	09150006225
CDGM-1.0	09150006122	CDGF-1.0	09150006222
CDGM-1.5	09150006121	CDGF-1.5	09150006221
CDGM-2.5	09150006126	CDGF-2.5	09150006226

线规 Wire gauge	$\Phi$	剥线长度 Stripping length
0.14-0.37 mm <sup>2</sup> AWG 26-22	0.9	8 mm
0.5 mm <sup>2</sup> AWG 20	1.1	8 mm
0.75 mm <sup>2</sup> AWG 18	1.3	8 mm
1 mm <sup>2</sup> AWG 18	1.45	8 mm
1.5 mm <sup>2</sup> AWG 16	1.75	8 mm
2.5 mm <sup>2</sup> AWG 14	2.25	6 mm

工具 Tools

冷压钳 Crimping tool



退针器 Removal tool



压接线经 Wire gauge	型号 Type	订货号 Part Number
0.14-4mm <sup>2</sup>	TL02G	09990000021

适用类型 For	型号 Type	订货号 Part Number
10A 冷压针	TL00	09990000012
10A Crimp contacts		

更多工具请参考 25-01~25-02页 More tools on P25-01~P25-02

# Ultra-high Density Inserts

## UTL-HDD-072 超高密度型插芯 250V 10A 72+⊕

### 插芯 Inserts

外壳尺寸：匹配16B外壳，详情请参考17-01-17-21页

Hoods/Housings: Matching 16B Hood Housing, detail on P17-01-P17-21

冷压连接 Crimp terminal



插芯 Inserts	型号 Type	订货号 Part Number
公 Male	UTL-HDD-072-MC	09160723001
母 Female	UTL-HDD-072-FC	09160723101

接插体之间的最大距离21mm  
Distance for contact max.21mm

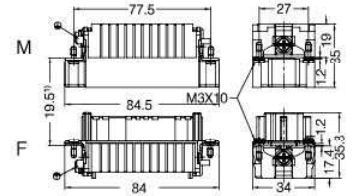

接插针排序

Contacts arrangement view from termination side

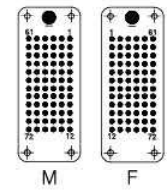

面板安装开孔图

Panel cut out for inserts for use without Hoods/housings

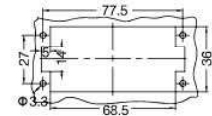

### 附件 Accessories

10A 冷压针 Crimp contacts

接触电阻 Contact resistance  $\leq 3m\Omega$   
镀银 Silver plated



公 Male	订货号 Part Number	母 Female	订货号 Part Number
CDSM-0.37	09150006104	CDSF-0.37	09150006204
CDSM-0.5	09150006103	CDSF-0.5	09150006203
CDSM-0.75	09150006105	CDSF-0.75	09150006205
CDSM-1.0	09150006102	CDSF-1.0	09150006202
CDSM-1.5	09150006101	CDSF-1.5	09150006201
CDSM-2.5	09150006106	CDSF-2.5	09150006206

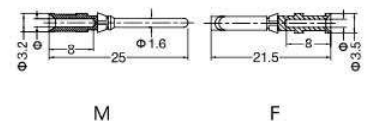

镀金 Gold plated



公 Male	订货号 Part Number	母 Female	订货号 Part Number
CDGM-0.37	09150006124	CDGF-0.37	09150006224
CDGM-0.5	09150006123	CDGF-0.5	09150006223
CDGM-0.75	09150006125	CDGF-0.75	09150006225
CDGM-1.0	09150006122	CDGF-1.0	09150006222
CDGM-1.5	09150006121	CDGF-1.5	09150006221
CDGM-2.5	09150006126	CDGF-2.5	09150006226

线规 Wire gauge	$\Phi$	剥线长度 Stripping length
0.14-0.37 mm <sup>2</sup>	AWG 26-22	0.9
0.5 mm <sup>2</sup>	AWG 20	1.1
0.75 mm <sup>2</sup>	AWG 18	1.3
1 mm <sup>2</sup>	AWG 18	1.45
1.5 mm <sup>2</sup>	AWG 16	1.75
2.5 mm <sup>2</sup>	AWG 14	2.25

工具 Tools

冷压钳 Crimping tool



退针器 Removal tool



压接线经 Wire gauge	型号 Type	订货号 Part Number
0.14-4mm <sup>2</sup>	TL02G	09990000021

适用类型 For	型号 Type	订货号 Part Number
10A 冷压针	TL00	09990000012
10A Crimp contacts		

更多工具请参考 25-01~25-02页 More tools on P25-01-P25-02

# Ultra-high Density Inserts

## UTL-HDD-108 超高密度型插芯 250V 10A 108+⊕

### 插芯 Inserts

外壳尺寸: 匹配24B外壳, 详情请参考18-01~18-22页

Hoods/Housings: Matching 24B Hood Housing, detail on P18-01~P18-22

冷压连接 Crimp terminal



插芯 Inserts	型号 Type	订货号 Part Number
公 Male	UTL-HDD-108-MC	09161083001
母 Female	UTL-HDD-108-FC	09161083101

接插体之间的最大距离24mm  
Distance for contact max.24mm

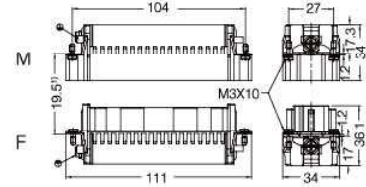

接插针排序

Contacts arrangement view from termination side

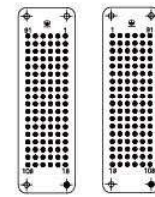

面板安装开孔图

Panel cut out for inserts for use without Hoods/housings

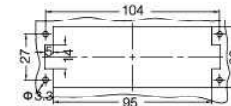

### 附件 Accessories

10A 冷压针 Crimp contacts

接触电阻 Contact resistance  $\leq 3m\Omega$   
镀银 Silver plated



公 Male	订货号 Part Number	母 Female	订货号 Part Number
CDSM-0.37	09150006104	CDSF-0.37	09150006204
CDSM-0.5	09150006103	CDSF-0.5	09150006203
CDSM-0.75	09150006105	CDSF-0.75	09150006205
CDSM-1.0	09150006102	CDSF-1.0	09150006202
CDSM-1.5	09150006101	CDSF-1.5	09150006201
CDSM-2.5	09150006106	CDSF-2.5	09150006206

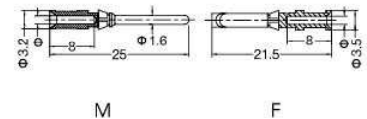

镀金 Gold plated



公 Male	订货号 Part Number	母 Female	订货号 Part Number
CDGM-0.37	09150006124	CDGF-0.37	09150006224
CDGM-0.5	09150006123	CDGF-0.5	09150006223
CDGM-0.75	09150006125	CDGF-0.75	09150006225
CDGM-1.0	09150006122	CDGF-1.0	09150006222
CDGM-1.5	09150006121	CDGF-1.5	09150006221
CDGM-2.5	09150006126	CDGF-2.5	09150006226

线规 Wire gauge	$\Phi$	剥线长度 Stripping length
0.14-0.37 mm <sup>2</sup> AWG 26-22	0.9	8 mm
0.5 mm <sup>2</sup> AWG 20	1.1	8 mm
0.75 mm <sup>2</sup> AWG 18	1.3	8 mm
1 mm <sup>2</sup> AWG 18	1.45	8 mm
1.5 mm <sup>2</sup> AWG 16	1.75	8 mm
2.5 mm <sup>2</sup> AWG 14	2.25	6 mm

工具 Tools

冷压钳 Crimping tool



退针器 Removal tool



压接线经 Wire gauge	型号 Type	订货号 Part Number
0.14-4mm <sup>2</sup>	TL02G	09990000021

适用类型 For	型号 Type	订货号 Part Number
10A 冷压针	TL00	09990000012
10A Crimp contacts		

更多工具请参考 25-01~25-02页 More tools on P25-01~P25-02



# Ultra-high Density Inserts

## UTL-HDD-216 超高密度型插芯 250V 10A 216+⊕

### 插芯 Inserts

外壳尺寸：匹配48B外壳，详情请参考20-01-20-02页

Hoods/Housings: Matching 48B Hood Housing, detail on P20-01~P20-02

冷压连接 Crimp terminal



插芯 Inserts	型号 Type	订货号 Part Number
公 Male	UTL-HDD-108-MC(1-108)	09161083001
	UTL-HDD-108-MC(109-216)	09161083011
母 Female	UTL-HDD-108-FC(1-108)	09161083101
	UTL-HDD-108-FC(109-216)	09161083111

接插器之间的最大距离21mm  
Distance for contact max.21mm

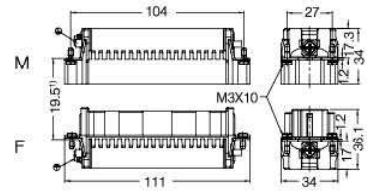

接插针排序

Contacts arrangement view from termination side

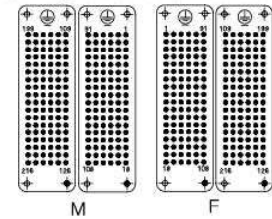

面板安装开孔图

Panel cut out for inserts for use without Hoods/housings

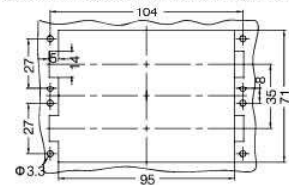

### 附件 Accessories

10A 冷压针 Crimp contacts

接触电阻 Contact resistance  $\leq 3m\Omega$   
镀银 Silver plated



公 Male	订货号 Part Number	母 Female	订货号 Part Number
CDSM-0.37	09150006104	CDSF-0.37	09150006204
CDSM-0.5	09150006103	CDSF-0.5	09150006203
CDSM-0.75	09150006105	CDSF-0.75	09150006205
CDSM-1.0	09150006102	CDSF-1.0	09150006202
CDSM-1.5	09150006101	CDSF-1.5	09150006201
CDSM-2.5	09150006106	CDSF-2.5	09150006206

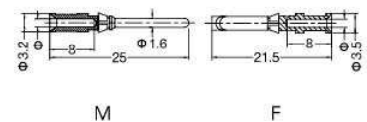

镀金 Gold plated



公 Male	订货号 Part Number	母 Female	订货号 Part Number
CDGM-0.37	09150006124	CDGF-0.37	09150006224
CDGM-0.5	09150006123	CDGF-0.5	09150006223
CDGM-0.75	09150006125	CDGF-0.75	09150006225
CDGM-1.0	09150006122	CDGF-1.0	09150006222
CDGM-1.5	09150006121	CDGF-1.5	09150006221
CDGM-2.5	09150006126	CDGF-2.5	09150006226

线规 Wire gauge	$\Phi$	剥线长度 Stripping length
0.14-0.37 mm <sup>2</sup> AWG 26-22	0.9	8 mm
0.5 mm <sup>2</sup> AWG 20	1.1	8 mm
0.75 mm <sup>2</sup> AWG 18	1.3	8 mm
1 mm <sup>2</sup> AWG 18	1.45	8 mm
1.5 mm <sup>2</sup> AWG 16	1.75	8 mm
2.5 mm <sup>2</sup> AWG 14	2.25	6 mm

工具 Tools

冷压钳 Crimping tool



压接线经 Wire gauge	型号 Type	订货号 Part Number
0.14-4mm <sup>2</sup>	TL02G	09990000021

退针器 Removal tool



适用类型 For	型号 Type	订货号 Part Number
10A 冷压针	TL00	09990000012
10A Crimp contacts		

更多工具请参考 25-01~25-02页 More tools on P25-01~P25-02

# UTL-HSB 系列 / HSB SERIES

35A 大电流型连接器 / 35A heavy-current connector



# Heavy-current Inserts

## UTL-HSB 大电流型插芯

### 技术参数 Technical Characteristics

规范	Specifications	
规范	Specifications	DIN EN 60 664
		DIN EN 61 984
插芯	Inserts	
依据 EN 61 984的额定电压	Electrical data acc. to EN 61 984	
接插件针数	Number Of Contacts	6,12+PE
额定电流	Rated Current	35A
相对地额定电压	Rated Voltage	400V
相间额定电压		690V
额定脉冲电压	Rated Impulse Voltage	6kV
污染程度	Pollution Degree	3
或	Or	35A 500 6kV 3
依据UL/CSA额定电压	Rated Voltage Acc.to UI CSA	600V
绝缘电阻	Insulation Resistance	$\geq 10^{10} \Omega$
材料	Material	聚碳酸酯 Polycarbonate
工作温度范围	Limiting Temperatures	-40°C...+125°C
依据UL94阻燃等级	Flammability Acc. To UL94	V0
可拔插次数	Mechanical Working Life-mating Cycles	$\geq 500$
插针	Contacts	
材料	Material	铜合金 Copper Alloy
表面处理	Surface	镀银 Hard-silver Plated
接触电阻	Contact Resistance	$\leq 1m\Omega$
螺钉连接	Screw Terminal	
导线规格	Wire Gauge	6mm <sup>2</sup>
AWG	AWG	10
拧紧力矩	Tightening Torque	1.2Nm

### 电流负载能力 Current Carrying Capacity

电流负载能力所受的限制主要来自包含接插针的接插体可承受的最大温度

The current carrying is limited by maximum temperature of materials for Inserts and contacts including terminals.

测试和控制过程依据 Measuring and testing techniques according to DIN EN 60512-5

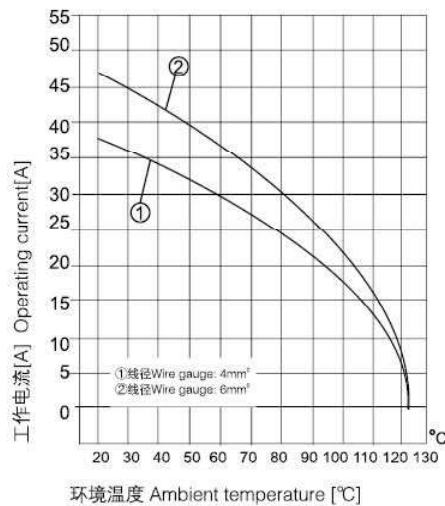



# Heavy-current Inserts

## UTL-HSB-006 大电流型插芯 400V/690V 35A 144+⊕

### 插芯 Inserts

外壳尺寸：匹配16B外壳，详情请参考17-01~17-21页

Hoods/Housings: Matching 16B Hood Housing, detail on P17-01~P17-21页

螺丝连接 Screw terminal



插芯 Inserts	型号 Type	订货号 Part Number
公 Male	UTL-HSB-006-M	09310062601
母 Female	UTL-HSB-006-F	09310062701

接插体之间的最大距离21mm  
Distance for contact max.21mm

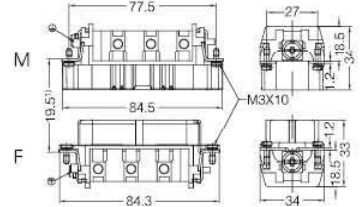

### 接插针排序

Contacts arrangement view from termination side

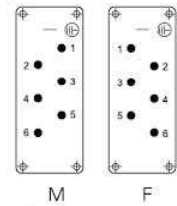

### 面板安装开孔图

Panel cut out for inserts for use without Hoods/housings

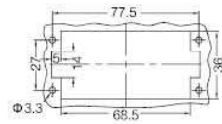

# Heavy-current Inserts

## UTL-HSB-012 大电流型插芯 400V/690V 35A 12+⊕

### 插芯 Inserts

外壳尺寸: 匹配32B外壳, 详情请参考19-01~19-04页

Hoods/Housings: Matching 32B Hood Housing, detail on P19-01~P19-04页

螺丝连接 Screw terminal



插芯 Inserts	型号 Type	订货号 Part Number
公 Male	UTL-HSB-006-M(1-6)	09310062601
	UTL-HSB-006-M(7-12)	09310062611
母 Female	UTL-HSB-006-F(1-6)	09310062701
	UTL-HSB-006-F(7-12)	09310062711

接插体之间的最大距离21mm  
Distance for contact max.21mm

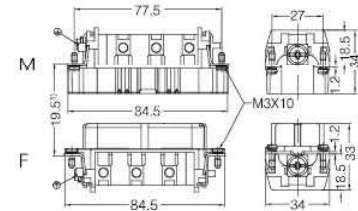

接插针排序

Contacts arrangement view from termination side

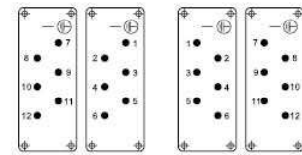

M

F

面板安装开孔图

Panel cut out for inserts for use without Hoods/housings

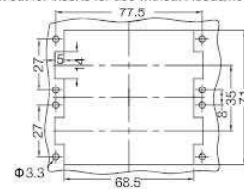

# UTL-HK 系列 / HK SERIES

组合型连接器 / Combination Connector



# Combination inserts

## UTL-HK 组合型插芯

### 技术参数 Technical Characteristics

规范	Specifications	
规范	Specifications	DIN EN 60 664
		DIN EN 61 984
插芯	Inserts	
接插件针数	Number Of Contacts	8/24+PE
依据 EN 61 984的额定电压	Electrical Data Acc. To EN 61 984	
电力区	Power Area	
-额定电流	-Rated Current	16A
-额定电压	-Rated Voltage	230/400V
-额定脉冲电压	-Rated Impulse Voltage	4kV
-污染程度	-Pollution Degree	3
-当污染程度2时的参数	-Pollution Degree 2 Also	10A 250V 4kV 2
信号区	Signal Area	
-额定电流	-Rated Current	10A
-额定电压	-Rated Voltage	160V
-额定脉冲电压	-Rated Impulse Voltage	2.5kV
-污染程度	-Pollution Degree	3
依据UL/CSA额定电压	Rated Voltage Acc.to UI CSA	600/300V
绝缘电阻	Insulation Resistance	$\geq 10^{10} \Omega$
材料	Material	聚碳酸酯 Polycarbonate
工作温度范围	Limiting Temperatures	-40°C...+125°C
阻燃等级	Flammability Acc. To UI94	V0
可拔插次数	Mechanical Working Life-mating Cycles	$\geq 500$
插针	Contacts	
强电针	Power Contacts	
-材料	-Material	铜合金 Copper Alloy
-表面处理	-Surface	镀金 Hard-gold Plated
		镀银 Hard-silver Plated
-接触电阻	-Contact Resistance	$\leq 1m\Omega$
-冷压连接	-Crimp Terminal	
- mm <sup>2</sup>	-mm <sup>2</sup>	0.5-4mm <sup>2</sup>
- AWG	-AWG	20-12
信号针	Signal Contacts	
-材料	-Material	铜合金 Copper Alloy
-表面处理	-Surface	镀金 Hard-gold Plated
		镀银 Hard-silver Plated
-接触电阻	-Contact Resistance	$\leq 3m\Omega$
-冷压连接	-Crimp Terminal	
- mm <sup>2</sup>	-mm <sup>2</sup>	0.14-2.5mm <sup>2</sup>
- AWG	-AWG	25-14

### 电流负载能力 Current Carrying Capacity

电流负载能力所受的限制主要来自包含接插针的接插体可承受的最大温度  
 The current carrying is limited by maximum temperature of materials for Inserts and contacts including terminals.  
 测试和控制过程依据 Measuring and testing techniques according to DIN EN 60512-5

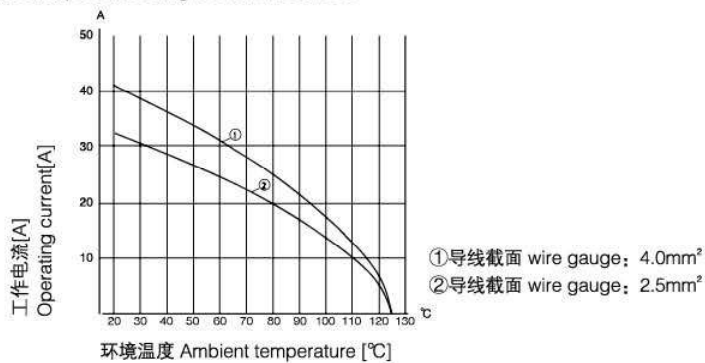

# Combination inserts

## UTL-HK-008/24 组合型插芯 400/160V 16/10A 8/24+⊕

### 插芯 Inserts

外壳尺寸: 匹配10B外壳, 详情请参考16-01-16-13页

Hoods/Housings: Matching 10B Hood Housing, detail on P16-01~P16-1

#### 冷压连接 Crimp Terminal



插芯 Inserts	型号 Type	订货号 Part Number
公 Male	UTL-HK-008/24-MC	09380323001
母 Female	UTL-HK-008/24-FC	09380323101

接插体之间的最大距离21mm  
Distance for contact max.21mm

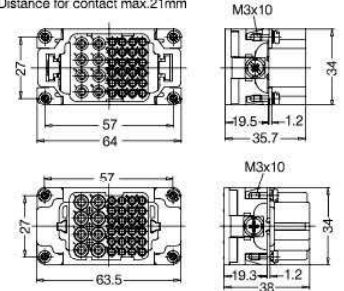

#### 接插针排序

Contacts arrangement view from termination side

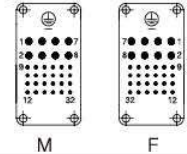

### 附件 Accessories

#### 10A 冷压针 Crimp contacts

接触电阻 Contact resistance  $\leq 3m\Omega$   
镀银 Silver plated



镀金 Gold plated



公 Male	订货号 Part Number	母 Female	订货号 Part Number
CDSM-0.37	09150006104	CDSM-0.37	09150006204
CDSM-0.5	09150006103	CDSM-0.5	09150006203
CDSM-0.75	09150006105	CDSM-0.75	09150006205
CDSM-1.0	09150006102	CDSM-1.0	09150006202
CDSM-1.5	09150006101	CDSM-1.5	09150006201
CDSM-2.5	09150006106	CDSM-2.5	09150006206
CDGM-0.37	09150006124	CDGM-0.37	09150006224
CDGM-0.5	09150006123	CDGM-0.5	09150006223
CDGM-0.75	09150006125	CDGM-0.75	09150006225
CDGM-1.0	09150006122	CDGM-1.0	09150006222
CDGM-1.5	09150006121	CDGM-1.5	09150006221
CDGM-2.5	09150006126	CDGM-2.5	09150006226

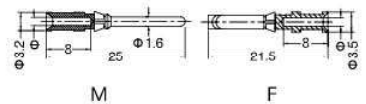

线规 Wire gauge	Φ	剥线长度 Stripping length	
0.14-0.37 mm <sup>2</sup>	AWG 26-22	0.9	8 mm
0.5 mm <sup>2</sup>	AWG 20	1.1	8 mm
0.75 mm <sup>2</sup>	AWG 18	1.3	8 mm
1 mm <sup>2</sup>	AWG 18	1.45	8 mm
1.5 mm <sup>2</sup>	AWG 16	1.75	8 mm
2.5 mm <sup>2</sup>	AWG 14	2.25	6 mm

#### 16A 冷压针 Crimp contacts

接触电阻 Contact resistance  $\leq 1m\Omega$   
镀银 Silver plated



镀金 Gold plate



公 Male	订货号 Part Number	母 Female	订货号 Part Number
CESM-0.37	09330006127	CESF-0.37	09330006227
CESM-0.5	09330006121	CESF-0.5	09330006220
CESM-0.75	09330006114	CESF-0.75	09330006214
CESM-1.0	09330006105	CESF-1.0	09330006205
CESM-1.5	09330006104	CESF-1.5	09330006204
CESM-2.5	09330006102	CESF-2.5	09330006202
CESM-3.0	09330006106	CESF-3.0	09330006206
CESM-4.0	09330006107	CESF-4.0	09330006207
CEGM-0.37	09330006117	CEGF-0.37	09330006217
CEGM-0.5	09330006122	CEGF-0.5	09330006222
CEGM-0.75	09330006115	CEGF-0.75	09330006215
CEGM-1.0	09330006118	CEGF-1.0	09330006218
CEGM-1.5	09330006116	CEGF-1.5	09330006216
CEGM-2.5	09330006123	CEGF-2.5	09330006223
CEGM-4.0	09330006119	CEGF-4.0	09330006221

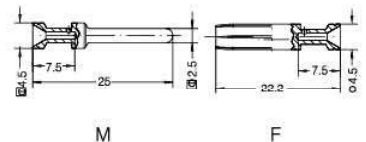

标识 Identification	线规 Wire gauge	剥线长度 Stripping length	
no groove	0.14-0.37mm <sup>2</sup>	AWG 26-22	7.5mm
no groove	0.5mm <sup>2</sup>	AWG 20	7.5mm
1 groove	0.75mm <sup>2</sup>	AWG 18	7.5mm
1 groove	1mm <sup>2</sup>	AWG 18	7.5mm
2 groove	1.5mm <sup>2</sup>	AWG 16	7.5mm
3 groove	2.5mm <sup>2</sup>	AWG 14	7.5mm
wide groove	3mm <sup>2</sup>	AWG 12	7.5mm
no groove	4mm <sup>2</sup>	AWG 12	7.5mm

#### 工具 Tools

冷压钳 Crimping tool



退针器 Removal tool



压接线经 Wire gauge	型号 Type	订货号 Part Number
0.14-4mm <sup>2</sup>	TL02G	09990000021

适用类型 For	型号 Type	订货号 Part Number
10A 冷压针 Crimp contacts	T100	09990000012

更多工具请参考 25-01~25-02页 More tools on P25-01~P25-02

# Combination inserts

## UTL-HK-004/4 组合型插芯

### 技术参数 Technical Characteristics

规范	Specifications	
规范	Specifications	DIN EN 60 664
		DIN EN 61 984
插芯	Inserts	
接插件针数	Number Of Contacts	4/4+PE
依据 DIN 61984的电气数据	Electrical Data Acc. To EN 61 984	
电力区	Power Area	
-额定电流	-Rated Current	70A
-额定电压	-Rated Voltage	690V
-额定脉冲电压	-Rated Impulse Voltage	8kV
-污染程度	-Pollution Degree	3
信号区	Signal Area	
-额定电流	-Rated Current	16A
-额定电压	-Rated Voltage	250V
-额定脉冲电压	-Rated Impulse Voltage	4kV
-污染程度	-Pollution Degree	3
依据UL/CSA额定电压	Rated Voltage Acc.to UI CSA	600V/230V
绝缘电阻	Insulation Resistance	$\geq 10^{10} \Omega$
材料	Material	聚碳酸酯 Polycarbonate
工作温度范围	Limiting Temperatures	-40°C...+125°C
阻燃等级(UL94)	Flammability Acc. To UI94	V0
可拔插次数	MechKnical Working Life-mating Cycles	$\geq 500$
插针	Contacts	
电力区	Power Area	
材料	Material	铜合金 Copper Alloy
-表面处理	Surface treatment	镀银 Hard-silver Plated
-接触电阻	Contact Resistance	$< 0.5m\Omega$
-冷压连接	Crimp Terminal	
- mm <sup>2</sup>	-mm <sup>2</sup>	10-25mm <sup>2</sup>
- AWG	-AWG	8-4
最大电缆直径	-Max.insulation diameter	11mm
-剥线长度	Wire stripping length	15.5mm
信号区	Signal Area	
-材料	Surface	铜合金 Copper Alloy
-表面处理	Surface treatment	镀银 Hard-silver Plated
-接触电阻	Contact Resistance	$\leq 1m\Omega$
-冷压连接	Crimp Terminal	
-mm <sup>2</sup>	-mm <sup>2</sup>	0.14-4mm <sup>2</sup>
-AWG	-AWG	26-12

### 电流负载能力 Current Carrying Capacity

电流负载能力所受的限制主要来自包含接插针的接插体可承受的最大温度

The current carrying is limited by maximum temperature of materials for Inserts and contacts including terminals.

测试和控制过程依据 Measuring and testing techniques according to DIN EN 60512-5

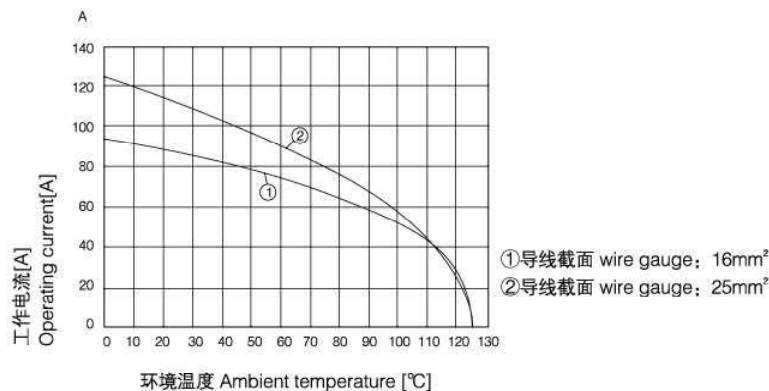

# Combination inserts

## UTL-HK-004/4 组合型插芯 690/250V 70/16A 4/4+⊕

### 插芯 Inserts

外壳尺寸: 匹配10B外壳, 详情请参考16-01-16-13页

Hoods/Housings: Matching 10B Hood Housing, detail on P16-01~P16-13

#### 冷压连接 Crimp Terminal



插芯 Inserts	型号 Type	订货号 Part Number
公 Male	UTL-HK-004/4-MC	09380082801
母 Female	UTL-HK-004/4-FC	09380082901

接插体之间的最大距离21mm  
Distance for contact max.21mm

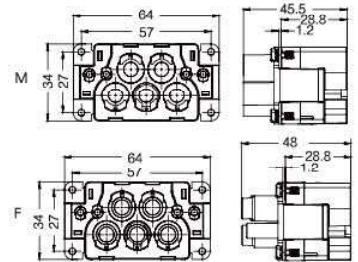

#### 接插针排序

Contacts arrangement view from termination side

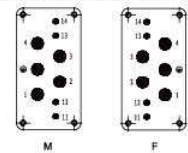

### 附件 Accessories

#### 70A 冷压针 Crimp contacts

接触电阻 ≤ 0.5 mΩ

Contact resistance ≤ 0.5 mΩ

镀银 silver plated



公 Male	订货号 Part Number	母 Female	订货号 Part Number
CKSM70-10	09320007104	CKSF70-10	09320007204
CKSM70-16	09320007105	CKSF70-16	09320007205
CKSM70-25	09320007106	CKSF70-25	09320007206

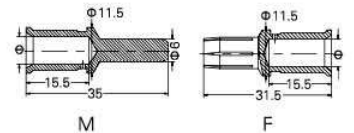

导线截面 Wire gauge	Φ	剥线长度 Stripping length
10 mm <sup>2</sup>	4.3	15.5 mm
16 mm <sup>2</sup>	5.5	15.5 mm
25 mm <sup>2</sup>	7	15.5 mm

电缆绞线依据 IEC 60 228-5  
for stranded wire according to IEC 60 228 Class 5

#### 16A 冷压针 Crimp contacts

接触电阻 Contact resistance ≤ 1mΩ

镀银 Silver plated



公 Male	订货号 Part Number	母 Female	订货号 Part Number
CESM-0.37	09330006127	CESF-0.37	09330006227
CESM-0.5	09330006121	CESF-0.5	09330006220
CESM-0.75	09330006114	CESF-0.75	09330006214
CESM-1.0	09330006105	CESF-1.0	09330006205
CESM-1.5	09330006104	CESF-1.5	09330006204
CESM-2.5	09330006102	CESF-2.5	09330006202
CESM-3.0	09330006106	CESF-3.0	09330006206
CESM-4.0	09330006107	CESF-4.0	09330006207

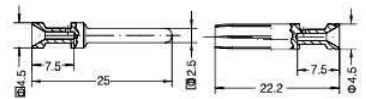

标示 Identification	线规 Wire gauge	剥线长度 Stripping length
no groove	0.14-0.37mm <sup>2</sup> AWG 26-22	7.5mm
no groove	0.5mm <sup>2</sup> AWG 20	7.5mm
1 groove	0.75mm <sup>2</sup> AWG 18	7.5mm
1 groove	1.0mm <sup>2</sup> AWG 18	7.5mm
2 groove	1.5mm <sup>2</sup> AWG 16	7.5mm
3 groove	2.5mm <sup>2</sup> AWG 14	7.5mm
wide groove	3mm <sup>2</sup> AWG 12	7.5mm
no groove	4mm <sup>2</sup> AWG 12	7.5mm

### 工具 Tools

#### 液压钳

Manual hydraulic clamp



压接线经 Wire gauge	型号 Type	订货号 Part Number
10-240mm <sup>2</sup>	TL05	09990000385

#### 冷压钳

Crimping tool



压接线经 Wire gauge	型号 Type	订货号 Part Number
0.5-4mm <sup>2</sup>	TL02G	09990000021

压接线径: 0.14-0.37mm<sup>2</sup>请选择TL02冷压钳

Wire gauge: 0.14-0.37mm<sup>2</sup> please select TL02 Crimping tool

#### 退针器

Removal tool



适用类型 For	型号 Type	订货号 Part Number
16A 冷压针 Crimp contacts	TL01	09990000059

# Combination inserts

## UTL-HK-004/0,004/2 组合型插芯

### 技术参数 Technical Characteristics

规范	Specifications	
规范	Specifications	DIN EN 60 664
		DIN EN 61 984
插芯	Inserts	
接插件针数	Number Of Contacts	4/0, 4/2+PE
依据 EN 61 984的额定电压	Electrical Data Acc. To EN 61 984	
电力区	Power Area	
-额定电流	-Rated Current	80A
-额定电压	-Rated Voltage	830V
-额定脉冲电压	-Rated Impulse Voltage	8kV
-污染程度	-Pollution Degree	3
-当污染程度2时的参数	-Pollution Degree 2 Also	80A 1000V 8kV 2
信号区	Signal Area	
-额定电流	-Rated Current	16A
-额定电压	-Rated Voltage	400V
-额定脉冲电压	-Rated Impulse Voltage	6kV
-污染程度	-Pollution Degree	3
-当污染程度2时的参数	-Pollution Degree 2 Also	16A 400/690V 6kV 2
依据UL/CSA额定电压	Rated Voltage Acc.to UI CSA	600/300V
绝缘电阻	Insulation Resistance	$\geq 10^{10} \Omega$
材料	Material	聚碳酸酯 Polycarbonate
工作温度范围	Limiting Temperatures	-40°C...+125°C
阻燃等级(UL94)	Flammability Acc. To UI94	V0
可拔插次数	Mechanical Working Life--mating Cycles	$\geq 500$
插针	Contacts	
电力区	Power Area	
-材料	-Material	铜合金 Copper Alloy
-表面处理	-Surface	镀银 Hard--silver Plated
-接触电阻	-Contact Resistance	$\leq 0.3m\Omega$
-螺钉连接	-Screw Terminal	
- mm <sup>2</sup>	-mm <sup>2</sup>	1.5--16mm <sup>2</sup>
- AWG	-AWG	16--6
-拧紧力矩	-Tightening Torque	
- mm <sup>2</sup>	- mm <sup>2</sup>	1.5 2.5 4 6 10 16
- N.m	- N.m	1.2 2 3 3 3 3
-剥线长度	-Stripping length	14mm
信号区	Signal Area	
-材料	-Material	铜合金 Copper Alloy
-表面处理	-Surface	镀银 Hard--silver Plated
-接触电阻	-Contact Resistance	$\leq 1m\Omega$
-螺钉连接	-Screw Terminal	
- mm <sup>2</sup>	-mm <sup>2</sup>	0.5--2.5mm <sup>2</sup>
- AWG	-AWG	20--14
-拧紧力矩	-Tightening Torque	0.5Nm
-剥线长度	-Stripping length	7.5mm

### 电流负载能力 Current Carrying Capacity

电流负载能力所受的限制主要来自包含接插针的接插体可承受的最大温度

The current carrying is limited by maximum temperature of materials for Inserts and contacts including terminals.

测试和控制过程依据 Measuring and testing techniques according to DIN EN 60512-5

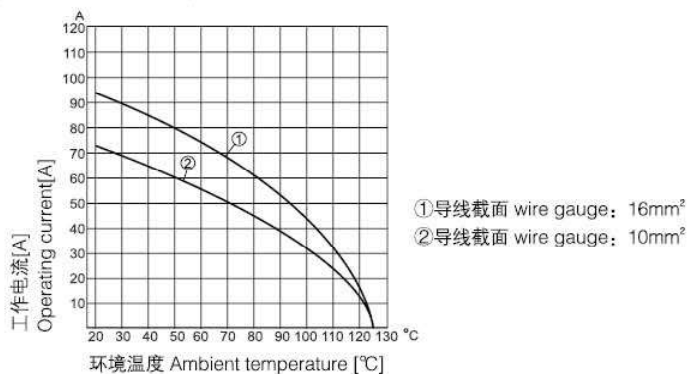



# Combination inserts

## UTL-HK-004/0,004/2 组合型插芯 830/400V 80/16A 4/0,4/2+⊕

### 插芯 Inserts

外壳尺寸：匹配16B外壳，详情请参考17-01~17-21页

Hoods/Housings: Matching 16B Hood Housing, detail on P17-01-P17-21

螺丝连接 Screw terminal



插芯 Inserts	型号 Type	订货号 Part Number
公 Male	UTL-HK-004/0-M	09380062611
母 Female	UTL-HK-004/0-F	09380062711



插芯 Inserts	型号 Type	订货号 Part Number
公 Male	UTL-HK-004/2-M	09380062601
母 Female	UTL-HK-004/2-F	09380062701

接插体之间的最大距离21mm  
Distance for contact max.21mm

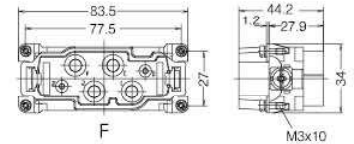
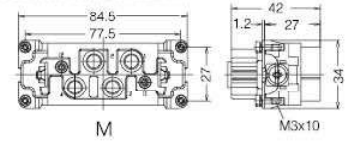

接插针排序

Contacts arrangement view from termination side

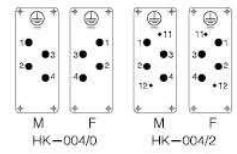

# Combination inserts

## UTL-HK-006/6 组合型插芯

### 技术参数 Technical Characteristics

规范	Specifications	
规范	Specifications	DIN EN 60 664
		DIN EN 61 984
插芯	Inserts	
接插件针数	Number Of Contacts	6/6+PE
依据 EN 61 984的额定电压	Electrical Data Acc. To EN 61 984	
电力区	Power Area	
-额定电流	-Rated Current	40A
-额定电压	-Rated Voltage	400/690V
-额定脉冲电压	-Rated Impulse Voltage	6kV
-污染程度	-Pollution Degree	3
信号区	Signal Area	
-额定电流	-Rated Current	16A
-额定电压	-Rated Voltage	230/400V
-额定脉冲电压	-Rated Impulse Voltage	4kV
-污染程度	-Pollution Degree	3
依据UL/CSA额定电压	Rated Voltage Acc.to UI CSA	600/600V
绝缘电阻	Insulation Resistance	$\geq 10^{10} \Omega$
材料	Material	聚碳酸酯 Polycarbonate
工作温度范围	Limiting Temperatures	-40°C...+125°C
阻燃等级(UL94)	Flammability Acc. To UI94	V0
可拔插次数	Mechanical Working Life-mating Cycles	$\geq 500$
插针	Contacts	
材料	Material	铜合金 Copper Alloy
表面处理	Surface	镀银 Hard-silver Plated
接线形式	Terminal	螺丝连接 Screw Terminal
接触电阻	Contact Resistance	
-电力区	Power Area	$\leq 0.3m\Omega$
-信号区	Signal Area	$\leq 1m\Omega$
导线规格	Wire gauge	
-电力区	Power Area	
- mm <sup>2</sup>	-mm <sup>2</sup>	4-10mm <sup>2</sup>
- AWG	-AWG	12-8
-信号区	Signal Area	
- mm <sup>2</sup>	-mm <sup>2</sup>	1-2.5mm <sup>2</sup>
- AWG	-AWG	18-4
拧紧力矩	Tightening Torque	
-电力区	Power Area	mm <sup>2</sup> 1.5 2.5 4 6 10 16 N.m 1.2 2 3 3 3 3
-信号区	Signal Area	0.5N.m

### 电流负载能力 Current Carrying Capacity

电流负载能力所受的限制主要来自包含接插针的接插体可承受的最大温度

The current carrying is limited by maximum temperature of materials for Inserts and contacts including terminals.

测试和控制过程依据 Measuring and testing techniques according to DIN EN 60512-5

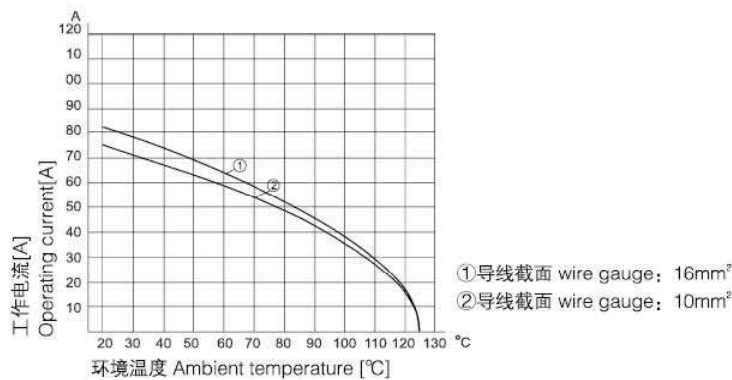

# Combination inserts

## UTL-HK-006/6 组合型插芯 690/400V 40/16A 6/6+⊕

### 插芯 Inserts

外壳尺寸：匹配16B外壳，详情请参考17-01~17-21页

Hoods/Housings: Matching 16B Hood Housing, detail on P17-01-P17-21

螺丝连接 Screw terminal



插芯 Inserts	型号 Type	订货号 Part Number
公 Male	UTL-HWK-006/6-M	09380122801
母 Female	UTL-HWK-006/6-F	09380122901

接插体之间的最大距离21mm  
Distance for contact max.21mm

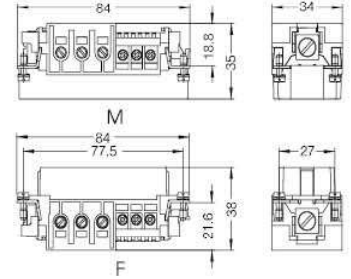

接插针排序

Contacts arrangement view from termination side

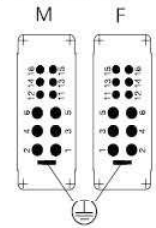

# Combination inserts

## UTL-HK-006/12 组合型插芯

### 技术参数 Technical Characteristics

规范	Specifications	
规范	Specifications	DIN EN 60 664
		DIN EN 61 984
插芯	Inserts	
接插件针数	Number Of Contacts	6/12+PE
依据 EN 61 984的额定电压	Electrical Data Acc. To EN 61 984	
电力区	Power Area	
-额定电流	-Rated Current	40A
-额定电压	-Rated Voltage	690V
-额定脉冲电压	-Rated Impulse Voltage	6kV
-污染程度	-Pollution Degree	3
信号区	Signal Area	
-额定电流	-Rated Current	10A
-额定电压	-Rated Voltage	230/400V
-额定脉冲电压	-Rated Impulse Voltage	4kV
-污染程度	-Pollution Degree	3
依据UL/CSA额定电压	Rated Voltage Acc.to UI CSA	600/300V
绝缘电阻	Insulation Resistance	$\geq 10^{10} \Omega$
材料	Material	聚碳酸酯 Polycarbonate
工作温度范围	Limiting Temperatures	-40°C...+125°C
阻燃等级(UL94)	Flammability Acc. To UI94	V0
可拔插次数	MechKnicl Working Life-mating Cycles	$\geq 500$
插针	Contacts	
强电针	Power Contacts	
-材料	-Material	铜合金 Copper Alloy
-表面处理	-Surface	镀银 Hard-silver Plated
-接触电阻	-Contact Resistance	$< 0.5m \Omega$
-轴向螺钉连接	-Axial Screw Terminal	
- mm <sup>2</sup>	-mm <sup>2</sup>	2.5-10mm <sup>2</sup>
- AWG	-AWG	14-8
-最大绝缘直径	-Max. Insulation Diameter	6.1mm
-拧紧力矩	-Tightening Torque	
- mm <sup>2</sup>	- mm <sup>2</sup>	2.5 4 6 10
- N.m	- N.m	1.5 1.5 2 2
-剥线长度	-Stripping length	
- mm <sup>2</sup>	- mm <sup>2</sup>	2.5 4 6 10
- mm	- mm	5 <sup>1</sup> 5 <sup>1</sup> 8 <sup>1</sup> 8 <sup>1</sup>
信号针	Signal Contacts	
-材料	-Material	铜合金 Copper Alloy
-表面处理	-Surface	镀银 Hard-silver Plated
-接触电阻	-Contact Resistance	$\leq 3m \Omega$
-轴向螺钉连接	-Axial Screw Terminal	
- mm <sup>2</sup>	-mm <sup>2</sup>	0.2-2.5mm <sup>2</sup>
- AWG	-AWG	24-14
-拧紧力矩	-Tightening Torque	0.8Nm
-剥线长度	-Stripping length	7.5mm

### 电流负载能力 Current Carrying Capacity

电流负载能力所受的限制主要来自包含接插针的接插体可承受的最大温度

The current carrying is limited by maximum temperature of materials for Inserts and contacts including terminals.

测试和控制过程依据 Measuring and testing techniques according to DIN EN 60512-5

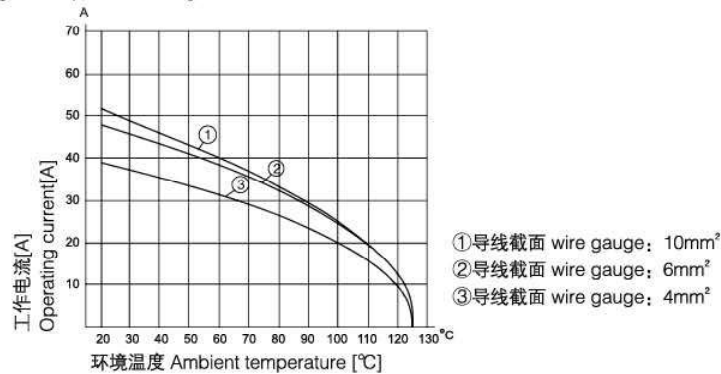

# Combination inserts

## UTL-HK-006/12 组合型插芯 690/400V 40/10A 6/12+⊕

### 插芯 Inserts

外壳尺寸: 匹配16B外壳, 详情请参考17-01~17-21页

Hoods/Housings: Matching 16B Hood Housing, detail on P17-01~P17-21

轴向螺栓连接/螺钉连接 Axial Screw Terminal/Screw terminal



插芯 Inserts	型号 Type	订货号 Part Number
公 Male	UTL-HK-006.1/12-M(2.5-8mm <sup>2</sup> )	09380182601
	UTL-HK-006.2/12-M(6-10mm <sup>2</sup> )	09380182602
母 Female	UTL-HK-006.1/12-F(2.5-8mm <sup>2</sup> )	09380182701
	UTL-HK-006.2/12-F(6-10mm <sup>2</sup> )	09380182702

接插体之间的最大距离21mm  
Distance for contact max.21mm

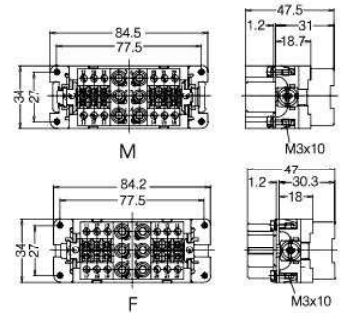

接插针排序

Contacts arrangement view from termination side

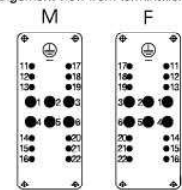

### 附件 Accessories

工具 Tools

内六角扳手  
hexagonal driver



描述 Description	型号 Type	订货号 Part Number
用于轴向夹紧螺栓 带T型把手 For Axial Setscrew With Grip	SW-2x40	09990000313

# Combination inserts

## UTL-HK-006/36 组合型插芯

### 技术参数 Technical Characteristics

规范	Specifications	
规范	Specifications	DIN EN 60 664
		DIN EN 61 984
插芯	Inserts	
接插件针数	Number Of Contacts	6/36+PE
依据 EN 61 984的额定电压	Electrical Data Acc. To EN 61 984	
电力区	Power Area	
-额定电流	-Rated Current	40A
-额定电压	-Rated Voltage	690V
-额定脉冲电压	-Rated Impulse Voltage	8kV
-污染程度	-Pollution Degree	3
信号区	Signal Area	
-额定电流	-Rated Current	10A
-额定电压	-Rated Voltage	160V
-额定脉冲电压	-Rated Impulse Voltage	2.5kV
-污染程度	-Pollution Degree	3
-当污染程度2时的参数	-Pollution Degree 2 Also	10A 250V 4kV 2
依据UL/CSA额定电压	Rated Voltage Acc.to UI CSA	600/300V
绝缘电阻	Insulation Resistance	$\geq 10^{10} \Omega$
材料	Material	聚碳酸酯 Polycarbonate
工作温度范围	Limiting Temperatures	-40°C...+125°C
阻燃等级(UL94)	Flammability Acc. To UI94	V0
可拔插次数	Mechanical Working Life-mating Cycles	$\geq 500$
插针	Contacts	
强电针	Power Contacts	
-材料	-Material	铜合金 Copper Alloy
-表面处理	-Surface	镀银 Hard-silver Plated 镀金 Hard-gold Plated
-接触电阻	-Contact Resistance	$\leq 0.3m\Omega$
冷压连接	Crimp Terminal	
- mm <sup>2</sup>	-mm <sup>2</sup>	1.5-6mm <sup>2</sup>
- AWG	-AWG	16-10
-最大绝缘直径	-Max. Insulation Diameter	5mm
信号针	Signal Contacts	
-材料	-Material	铜合金 Copper Alloy
-表面处理	-Surface	镀银 Hard-silver Plated 镀金 Hard-gold Plated
-接触电阻	-Contact Resistance	$\leq 3m\Omega$
冷压连接	Crimp Terminal	
- mm <sup>2</sup>	-mm <sup>2</sup>	0.14-2.5mm <sup>2</sup>
- AWG	-AWG	26-14

### 电流负载能力 Current Carrying Capacity

电流负载能力所受的限制主要来自包含接插针的接插体可承受的最大温度

The current carrying is limited by maximum temperature of materials for Inserts and contacts including terminals.

测试和控制过程依据 Measuring and testing techniques according to DIN EN 60512-5

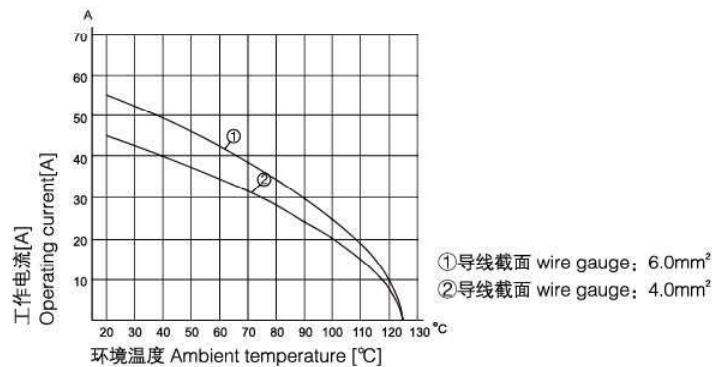

# Combination inserts

## UTL-HK-006/36 组合型插芯 690/160V 40/10A 6/36+⊕

### 插芯 Inserts

外壳尺寸: 匹配16B外壳, 详情请参考17-01-17-21页

Hoods/Housings: Matching 16B Hood Housing, detail on P17-01~P17-4

冷压连接 Crimp Terminal



插芯 Inserts	型号 Type	订货号 Part Number
公 Male	UTL-HK-006/36-MC	09380423001
母 Female	UTL-HK-006/36-FC	09380423101

接插体之间的最大距离21mm  
Distance for contact max.21mm

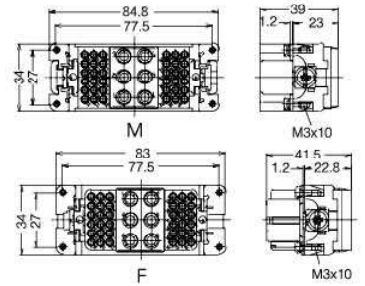

接插针排序

Contacts arrangement view from termination side

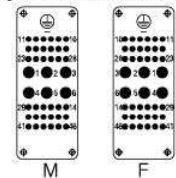

### 附件 Accessories

10A 冷压针 Crimp contacts

接触电阻Contact resistance  $\leq 3m\Omega$   
镀银 Silver plated



镀金 Gold plated



公 Male	订货号 Part Number	母 Female	订货号 Part Number
CDSM-0.37	09150006104	CDSM-0.37	09150006204
CDSM-0.5	09150006103	CDSM-0.5	09150006203
CDSM-0.75	09150006105	CDSM-0.75	09150006205
CDSM-1.0	09150006102	CDSM-1.0	09150006202
CDSM-1.5	09150006101	CDSM-1.5	09150006201
CDSM-2.5	09150006106	CDSM-2.5	09150006206
CDGM-0.37	09150006124	CDGM-0.37	09150006224
CDGM-0.5	09150006123	CDGM-0.5	09150006223
CDGM-0.75	09150006125	CDGM-0.75	09150006225
CDGM-1.0	09150006122	CDGM-1.0	09150006222
CDGM-1.5	09150006121	CDGM-1.5	09150006221
CDGM-2.5	09150006126	CDGM-2.5	09150006226

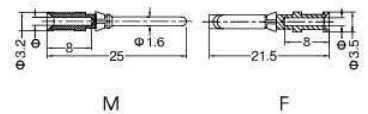

线规 Wire gauge	$\Phi$	剥线长度 Stripping length
0.14-0.37 mm <sup>2</sup>	AWG 28-22	0.9
0.5 mm <sup>2</sup>	AWG 20	1.1
0.75 mm <sup>2</sup>	AWG 18	1.3
1 mm <sup>2</sup>	AWG 18	1.45
1.5 mm <sup>2</sup>	AWG 16	1.75
2.5 mm <sup>2</sup>	AWG 14	2.25

40A 冷压针 Crimp contacts

接触电阻Contact resistance  $\leq 1m\Omega$   
镀银 Silver plated



镀金 Gold plated



公 Male	订货号 Part Number	母 Female	订货号 Part Number
CCSM-1.5	09320006104	CCSF-1.5	09320006204
CCSM-2.5	09320006105	CCSF-2.5	09320006205
CCSM-4.0	09320006107	CCSF-4.0	09320006207
CCSM-6.0	09320006108	CCSF-6.0	09320006208
CCGM-1.5	09320006124	CCGF-1.5	09320006224
CCGM-2.5	09320006125	CCGF-2.5	09320006225
CCGM-4.0	09320006127	CCGF-4.0	09320006227
CCGM-6.0	09320006128	CCGF-6.0	09320006228

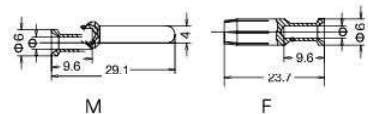

线规 Wire gauge	$\Phi$	剥线长度 Stripping length
1.5 mm <sup>2</sup>	AWG 16	1.75
2.5 mm <sup>2</sup>	AWG 14	2.25
4 mm <sup>2</sup>	AWG 12	2.85
6 mm <sup>2</sup>	AWG 10	3.5

工具 Tools

冷压钳 Crimping



退针器 Removal to



压接线经 Wire gauge	型号 Type	订货号 Part Number
0.14-4mm <sup>2</sup>	TL02G	09990000021
1.5-6mm <sup>2</sup>	TL02-0G	09990000110

适用类型 For	型号 Type	订货号 Part Number
10A 冷压针 Crimp contacts	TL00	09990000012
40A 冷压针 Crimp contacts	TL06	099900000305

# Combination inserts

## UTL-HK-006/36 组合型插芯

### 技术参数 Technical Characteristics

规范	Specifications	
规范	Specifications	DIN EN 60 664
		DIN EN 61 984
插芯	Inserts	
接插件针数	Number Of Contacts	12/2+PE
依据 EN 61 984的额定电压	Electrical Data Acc. To EN 61 984	
电力区	Power Area	
-额定电流	-Rated Current	40A
-额定电压	-Rated Voltage	690V
-额定脉冲电压	-Rated Impulse Voltage	8kV
-污染程度	-Pollution Degree	3
信号区	Signal Area	
-额定电流	-Rated Current	10A
-额定电压	-Rated Voltage	250V
-额定脉冲电压	-Rated Impulse Voltage	4kV
-污染程度	-Pollution Degree	3
依据UL/CSA额定电压	Rated Voltage Acc.to UI CSA	600/300V
绝缘电阻	Insulation Resistance	$\geq 10^{10} \Omega$
材料	Material	聚碳酸酯 Polycarbonate
工作温度范围	Limiting Temperatures	-40°C...+125°C
阻燃等级(UL94)	Flammability Acc. To UI94	V0
可拔插次数	MechKnical Working Life-mating Cycles	$\geq 500$
插针	Contacts	
强电针	Power Contacts	
-材料	-Material	铜合金 Copper Alloy
-表面处理	-Surface	镀银 Hard-silver Plated
		镀金 Hard-gold Plated
-接触电阻	-Contact Resistance	$\leq 0.3m\Omega$
-冷压连接	-Crimp Terminal	
- mm <sup>2</sup>	-mm <sup>2</sup>	1.5-6mm <sup>2</sup>
- AWG	-AWG	16-10
-最大绝缘直径	-Max. Insulation Diameter	
信号针	Signal Contacts	
-材料	-Material	铜合金 Copper Alloy
-表面处理	-Surface	镀银 Hard-silver Plated
		镀金 Hard-gold Plated
-接触电阻	-Contact Resistance	$\leq 3m\Omega$
-冷压连接	-Crimp Terminal	
- mm <sup>2</sup>	-mm <sup>2</sup>	0.14-2.5mm <sup>2</sup>
- AWG	-AWG	26-14

### 电流负载能力 Current Carrying Capacity

电流负载能力所受的限制主要来自包含接插针的接插体可承受的最大温度

The current carrying is limited by maximum temperature of materials for Inserts and contacts including terminals.

测试和控制过程依据 Measuring and testing techniques according to DIN EN 60512-5

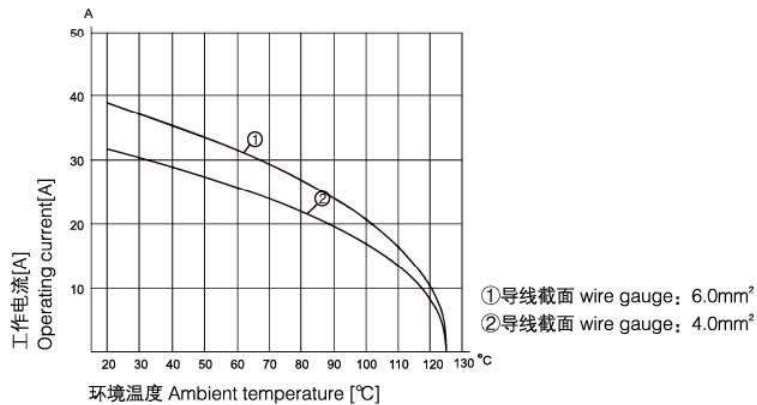



# Combination inserts

## UTL-HK-006/36 组合型插芯 690/160V 40/10A 6/36+⊕

### 插芯 Inserts

外壳尺寸: 匹配16B外壳, 详情请参考17-01~17-21页

Hoods/Housings: Matching 16B Hood Housing, detail on P17-01~P17-21

#### 冷压连接 Crimp Terminal



插芯 Inserts	型号 Type	订货号 Part Number
公 Male	UTL-HK-012/2-MC	09320123001
母 Female	UTL-HK-012/2-FC	09320123101

接插体之间的最大距离21mm

Distance for contact max.21mm

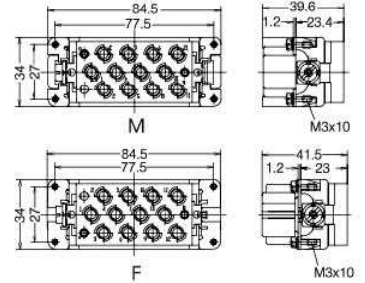

接插针排序

Contacts arrangement view from termination side

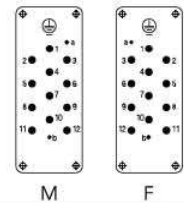

### 附件 Accessories

#### 10A 冷压针 Crimp contacts

接触电阻 Contact resistance  $\leq 3m\Omega$   
镀银 Silver plated



镀金 Gold plated



公 Male	订货号 Part Number	母 Female	订货号 Part Number
CDSM-0.37	09150006104	CDSM-0.37	09150006204
CDSM-0.5	09150006103	CDSM-0.5	09150006203
CDSM-0.75	09150006105	CDSM-0.75	09150006205
CDSM-1.0	09150006102	CDSM-1.0	09150006202
CDSM-1.5	09150006101	CDSM-1.5	09150006201
CDSM-2.5	09150006106	CDSM-2.5	09150006206
CDGM-0.37	09150006124	CDGM-0.37	09150006224
CDGM-0.5	09150006123	CDGM-0.5	09150006223
CDGM-0.75	09150006125	CDGM-0.75	09150006225
CDGM-1.0	09150006122	CDGM-1.0	09150006222
CDGM-1.5	09150006121	CDGM-1.5	09150006221
CDGM-2.5	09150006126	CDGM-2.5	09150006226

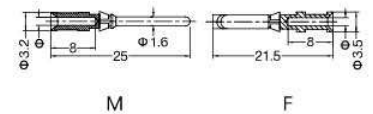

线规 Wire gauge	$\Phi$	剥线长度 Stripping length
0.14-0.37 mm <sup>2</sup>	AWG 26-22	0.9
0.5 mm <sup>2</sup>	AWG 20	1.1
0.75 mm <sup>2</sup>	AWG 18	1.3
1 mm <sup>2</sup>	AWG 18	1.45
1.5 mm <sup>2</sup>	AWG 16	1.75
2.5 mm <sup>2</sup>	AWG 14	2.25

#### 40A 冷压针 Crimp contacts

接触电阻 Contact resistance  $\leq 1m\Omega$   
镀银 Silver plated



镀金 Gold plated



公 Male	订货号 Part Number	母 Female	订货号 Part Number
CCSM-1.5	09320006104	CCSF-1.5	09320006204
CCSM-2.5	09320006105	CCSF-2.5	09320006205
CCSM-4.0	09320006107	CCSF-4.0	09320006207
CCSM-6.0	09320006108	CCSF-6.0	09320006208
CCGM-1.5	09320006124	CCGF-1.5	09320006224
CCGM-2.5	09320006125	CCGF-2.5	09320006225
CCGM-4.0	09320006127	CCGF-4.0	09320006227
CCGM-6.0	09320006128	CCGF-6.0	09320006228

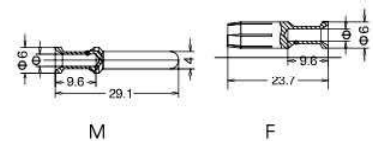

线规 Wire gauge	$\Phi$	剥线长度 Stripping length
1.5 mm <sup>2</sup>	AWG 16	1.75
2.5 mm <sup>2</sup>	AWG 14	2.25
4 mm <sup>2</sup>	AWG 12	2.65
6 mm <sup>2</sup>	AWG 10	3.5

### 工具 Tools

#### 冷压钳 Crimping



压接线径 Wire gauge	型号 Type	订货号 Part Number
0.14-4mm <sup>2</sup>	TL02G	09990000021
1.5-6mm <sup>2</sup>	TL02-0G	09990000110

#### 退针器 Removal to



适用类型 For	型号 Type	订货号 Part Number
10A 冷压针 Crimp contacts	TL00	09990000012
40A 冷压针 Crimp contacts	TL06	09990000305

# Combination inserts

## UTL-HK-006/6 组合型插芯

### 技术参数 Technical Characteristics

规范	Specifications	
规范	Specifications	DIN EN 60 664
		DIN EN 61 984
插芯	Inserts	
接插件针数	Number Of Contacts	6/6+PE
依据 EN 61 984的额定电压	Electrical Data Acc. To EN 61 984	
电力区	Power Area	
-额定电流	-Rated Current	100A
-额定电压	-Rated Voltage	690V
-额定脉冲电压	-Rated Impulse Voltage	8kV
-污染程度	-Pollution Degree	3
-当污染程度2时的参数	-Pollution Degree 2 Also	100A 1000V 8kV 2
信号区	Signal Area	
-额定电流	-Rated Current	16A
-额定电压	-Rated Voltage	400V
-额定脉冲电压	-Rated Impulse Voltage	6kV
-污染程度	-Pollution Degree	3
依据UL额定电压	Rated Voltage Acc.toUI	600/300V
依据UL/CSA额定电压	Rated Voltage Acc.to UI CSA	600/600V
依据UL/CSA额定电流	Rated Current Acc.to UI CSA	100/15A
绝缘电阻	Insulation Resistance	$\geq 10^{10} \Omega$
材料	Material	聚碳酸酯 Polycarbonate
工作温度范围	Limiting Temperatures	-40°C...+ 125°C
阻燃等级(UL94)	Flammability Acc. To UI94	V0
可拔插次数	Mechanical Working Life-mating Cycles	$\geq 500$
插针	Contacts	
强电针	Power Contacts	
-材料	-Material	铜合金 Copper Alloy
-表面处理	-Surface	镀银 Hard-silver Plated
-接触电阻	-Contact Resistance	$\leq 0.5m\Omega$
-轴向螺钉连接	-Axial Screw Terminal	
- mm <sup>2</sup>	-mm <sup>2</sup>	16-35mm <sup>2</sup>
- AWG	-AWG	5-2
-最大绝缘直径	-Max. Insulation Diameter	11.4mm
-拧紧力矩	-Tightening Torque	
- mm <sup>2</sup>	- mm <sup>2</sup>	16 25 35
- N.m	- N.m	6 7 8
-剥线长度	-Stripping length	13 <sup>+1</sup> mm
信号针	Signal Contacts	
-材料	-Material	铜合金 Copper Alloy
-表面处理	-Surface	镀银 Hard-silver Plated
-接触电阻	-Contact Resistance	$\leq 3m\Omega$
-轴向螺钉连接	-Axial Screw Terminal	
- mm <sup>2</sup>	-mm <sup>2</sup>	0.2-2.5mm <sup>2</sup>
- AWG	-AWG	24-13
-拧紧力矩	-Tightening Torque	0.8Nm
-剥线长度	-Stripping length	7.5mm

### 电流负载能力 Current Carrying Capacity

电流负载能力所受的限制主要来自包含接插针的接插体可承受的最大温度

The current carrying is limited by maximum temperature of materials for Inserts and contacts including terminals.

测试和控制过程依据 Measuring and testing techniques according to DIN EN 60512-5

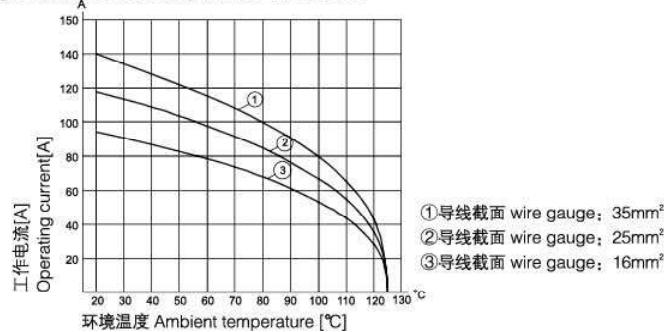

# Combination inserts

## UTL-HK-006/6 组合型插芯 690/400V 100/16A 6/6+⊕

### 插芯 Inserts

外壳尺寸：匹配24B外壳，详情请参考18-01~18-22页

Hoods/Housings: Matching 24B Hood Housing, detail on P18-01-P18-22

轴向螺钉连接 Axial Screw Terminal



插芯 Inserts	型号 Type	订货号 Part Number
公 Male	UTL-HK-006/6-M	09380122651
母 Female	UTL-HK-006/6-F	09380122751

接插体之间的最大距离21mm  
Distance for contact max.21mm

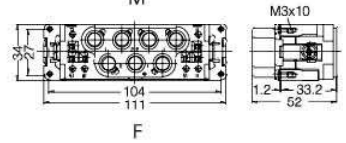
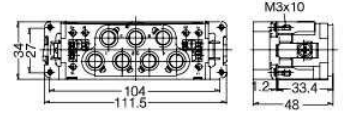

接插针排序

Contacts arrangement view from termination side

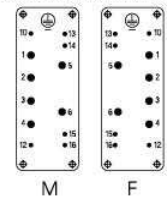

### 附件 Accessories

工具 Tools

内六角扳手  
hexagonal driver



描述 Description	型号 Type	订货号 Part Number
用于轴向夹紧螺栓 带T型把手 For Axial Setscrew With Grip	SW-4x100	09990000363

# Combination inserts

## UTL-HK-008/0 组合型插芯

### 技术参数 Technical Characteristics

规范	Specifications	
规范	Specifications	DIN EN 60 664
		DIN EN 61 984
插芯	Inserts	
接插件针数	Number Of Contacts	8/0+PE
依据 EN 61 984的额定电压	Electrical Data Acc. To EN 61 984	
电力区	Power Area	
-额定电流	-Rated Current	100A
-额定电压	-Rated Voltage	690V
-额定脉冲电压	-Rated Impulse Voltage	8kV
-污染程度	-Pollution Degree	3
-当污染程度2时的参数	-Pollution Degree 2 Also	100A 1000V 8kV 2
依据UL/CSA额定电压	Rated Voltage Acc.to UI CSA	600V
依据UL/CSA额定电流	Rated Current Acc.to UI CSA	82A
绝缘电阻	Insulation Resistance	$\geq 10^{10} \Omega$
材料	Material	聚碳酸酯 Polycarbonate
工作温度范围	Limiting Temperatures	-40°C...+125°C
阻燃等级(UL94)	Flammability Acc. To UI94	V0
可拔插次数	Mechanical Working Life-mating Cycles	$\geq 500$
插针	Contacts	
材料	Material	铜合金 Copper Alloy
表面处理	Surface	镀银 Hard-silver Plated
接触电阻	Contact Resistance	$\leq 0.5m\Omega$
轴向螺钉连接	Axial Screw Terminal	
- mm <sup>2</sup>	-mm <sup>2</sup>	10-25mm <sup>2</sup>
- AWG	-AWG	7-3
最大绝缘直径	Max. Insulation Diameter	11.4mm
拧紧力矩	Tightening Torque	
- mm <sup>2</sup>	- mm <sup>2</sup>	10 16 25
- AWG	- AWG	6 6 7
剥线长度	Stripping length	13 <sup>+1</sup> mm

### 电流负载能力 Current Carrying Capacity

电流负载能力所受的限制主要来自包含接插针的接插体可承受的最大温度

The current carrying is limited by maximum temperature of materials for Inserts and contacts including terminals.

测试和控制过程依据 Measuring and testing techniques according to DIN EN 60512-5

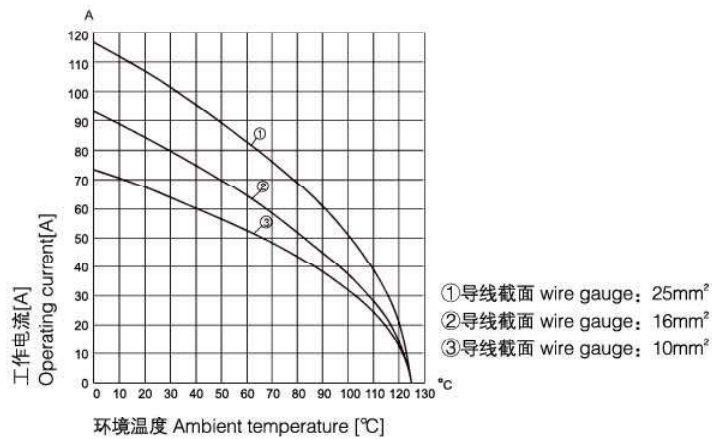

## Combination inserts

### UTL-HK-008/0 组合型插芯 690V/100A 8/0+⊕

#### 插芯 Inserts

外壳尺寸: 匹配24B外壳, 详情请参考18-01~18-22页

Hoods/Housings: Matching 24B Hood Housing, detail on P18-01~P18-22

轴向螺钉连接 Axial Screw Terminal



插芯 Inserts	型号 Type	订货号 Part Number
公 Male	UTL-HK-008/0-M	09380082653
母 Female	UTL-HK-008/0-F	09380082753

接插体之间的最大距离21mm  
Distance for contact max.21mm

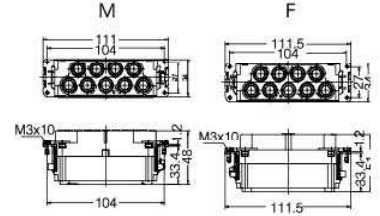

接插针排序

Contacts arrangement view from termination side

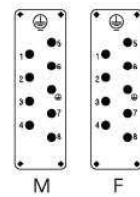

#### 附件 Accessories

工具 Tools

内六角扳手  
hexagonal driver



描述 Description	型号 Type	订货号 Part Number
用于轴向夹紧螺栓 带T型把手 For Axial Setscrew With Grip	SW-4x100	09990000363

# Combination inserts

## UTL-HK-004/8 组合型插芯

### 技术参数 Technical Characteristics

规范	Specifications	
规范	Specifications	DIN EN 60 664
		DIN EN 61 984
插芯	Inserts	
接插件针数	Number Of Contacts	4/8+PE
依据 EN 61 984的额定电压	Electrical Data Acc. To EN 61 984	
电力区	Power Area	
-额定电流	-Rated Current	80A
-额定电压	-Rated Voltage	400V
-额定脉冲电压	-Rated Impulse Voltage	6kV
-污染程度	-Pollution Degree	3
-当污染程度2时的参数	-Pollution Degree 2 Also	80A 400/690V 6kV 2
信号区	Signal Area	
-额定电流	-Rated Current	16A
-额定电压	-Rated Voltage	400V
-额定脉冲电压	-Rated Impulse Voltage	6kV
-污染程度	-Pollution Degree	3
依据UL/CSA额定电压	Rated Voltage Acc.to UI CSA	600/600V
绝缘电阻	Insulation Resistance	$\geq 10^{10} \Omega$
材料	Material	聚碳酸酯 Polycarbonate
工作温度范围	Limiting Temperatures	-40°C...+125°C
阻燃等级(UL94)	Flammability Acc. To UI94	V0
可拔插次数	Mechanical Working Life-mating Cycles	$\geq 500$
插针	Contacts	
电力区	Power Area	
-材料	-Material	铜合金 Copper Alloy
-表面处理	-Surface	镀银 Hard-silver Plated
-接触电阻	-Contact Resistance	$\leq 0.3m\Omega$
-螺钉连接	-Screw Terminal	
- mm <sup>2</sup>	-mm <sup>2</sup>	1.5-16mm <sup>2</sup>
- AWG	-AWG	16-6
-拧紧力矩	-Tightening Torque	
- mm <sup>2</sup>	- mm <sup>2</sup>	1.5 2.5 4 6 10 16
- N.m	- N.m	1.2 2 3 3 3 3
-剥线长度	-Stripping length	14mm
信号区	Signal Area	
-材料	-Material	铜合金 Copper Alloy
-表面处理	-Surface	镀银 Hard-silver Plated
-接触电阻	-Contact Resistance	$\leq 1m\Omega$
-螺钉连接	-Screw Terminal	
- mm <sup>2</sup>	-mm <sup>2</sup>	0.5-2.5mm <sup>2</sup>
- AWG	-AWG	20-14
-拧紧力矩	-Tightening Torque	0.5Nm
-剥线长度	-Stripping length	7.5mm

### 电流负载能力 Current Carrying Capacity

电流负载能力所受的限制主要来自包含接插针的接插体可承受的最大温度

The current carrying is limited by maximum temperature of materials for Inserts and contacts including terminals.

测试和控制过程依据 Measuring and testing techniques according to DIN EN 60512-5

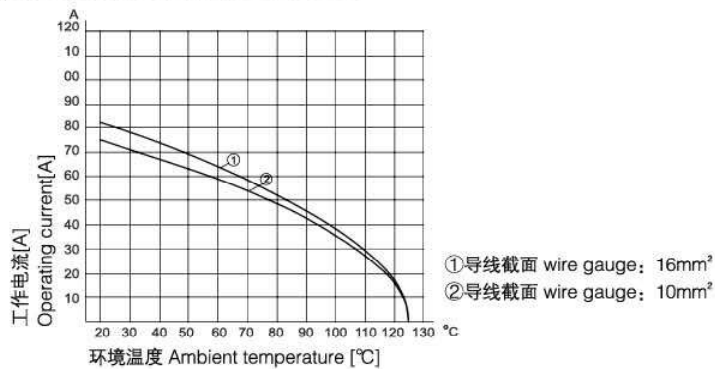

# Combination inserts

## UTL-HK-004/8 组合型插芯 400/400V 80/16A 4/8+⊕

### 插芯 Inserts

外壳尺寸：匹配24B外壳，详情请参考18-01~18-22页

Hoods/Housings: Matching 24B Hood Housing, detail on P18-01~P18-22

螺丝连接 Screw terminal

插芯 Inserts	型号 Type	订货号 Part Number
公 Male	UTL-HK-004/8-M	09380122601
母 Female	UTL-HK-004/8-F	09380122701



接插体之间的最大距离21mm  
Distance for contact max.21mm

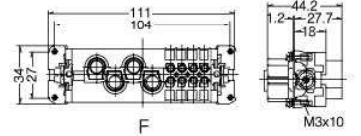
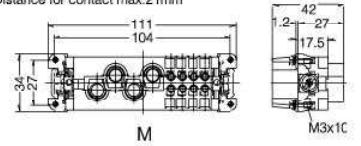

接插针排序  
Contacts arrangement view from termination side

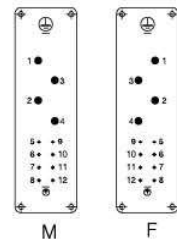

# UTL-HE AV 系列 / HE AV SERIES

伸长型插芯 / Extendible Inserts





# Extendible Inserts

## UTL-HE AV 伸长型插芯

### 技术参数 Technical Characteristics

规范	Specifications	
规范	Specifications	DIN EN 60 664
		DIN EN 61 984
插芯	Inserts	
依据 EN 61 984的额定电压	Electrical Data Acc. To EN 61 984	
接插件针数	Number Of Contacts	6, 10, 16, 24, 32(2x16), 48(2x24)+PE
额定电流	Rated Current	16A
额定电压	Rated Voltage	500V
额定脉冲电压	Rated Impulse Voltage	6kV
污染程度	Pollution Degree	3
污染等级2时的参数	Pollution Degree 2 Also	16A 400/690V 6kV 2
依据UL/CSA额定电压	Rated Voltage Acc.to UI CSA	600V
绝缘电阻	Insulation Resistance	$\geq 10^{10} \Omega$
材料	Material	聚碳酸酯 Polycarbonate
工作温度范围	Limiting Temperatures	-40°C...+125°C
依据UL94阻燃等级	Flammability Acc. To UL94	V0
可拔插次数	Mechanical Working Life-mating Cycles	$\geq 500$
插针	Contacts	
材料	Material	铜合金 Copper Alloy
表面处理	Surface	
接合侧		镀银 Hard-Silver Plated
接线侧		镀锡 Tin plated
接触电阻	Contact Resistance	$\leq 4m \Omega$
螺钉连接	Screw Terminal	
mm <sup>2</sup>	mm <sup>2</sup>	0.2-2.5mm <sup>2</sup>
AWG	AWG	24-14
拧紧/检测力矩		0.5Nm
终端角夹		
mm <sup>2</sup>	mm <sup>2</sup>	0.14-2.5mm <sup>2</sup>
AWG	AWG	26-14

### 电流负载能力 Current Carrying Capacity

电流负载能力所受的限制主要来自包含接插针的接插体可承受的最大温度

The current carrying is limited by maximum temperature of materials for Inserts and contacts including terminals.

测试和控制过程依据 Measuring and testing techniques according to DIN EN 60512-5

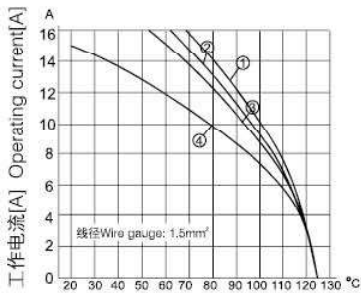

环境温度 Ambient temperature [°C]

- ① UTL-HE-006-M.AV/F.AV
- ② UTL-HE-010-M.AV/F.AV
- ③ UTL-HE-016-M.AV/F.AV
- ④ UTL-HE-024-M.AV/F.AV

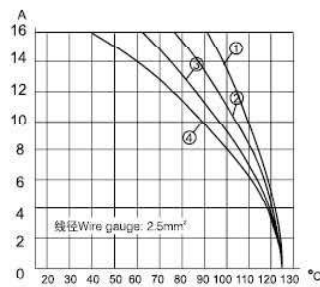

- ① UTL-HE-006-M.AV/F.AV
- ② UTL-HE-010-M.AV/F.AV
- ③ UTL-HE-016-M.AV/F.AV
- ④ UTL-HE-024-M.AV/F.AV

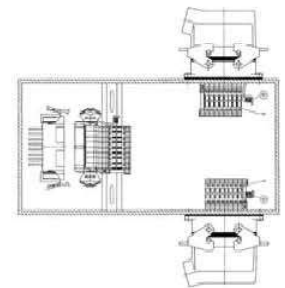

# Extendible Inserts

## UTL-HE AV 伸长型插芯 500V 16A 6+⊕

### 插芯 Inserts

外壳尺寸：匹配6B不封底下壳外壳

Hoods/Housings: Matching 6B bulkhead mounting housings

公插芯 螺钉连接 Male Inserts Screw Terminal



规格Size	描述Description	型号 Type	订货号 Part Number
6B	左侧 Left Hand Version	UTL-HE-006-M.AV.L	09330064626
6B	右侧 Right Hand Version	UTL-HE-006-M.AV.R	09330064636

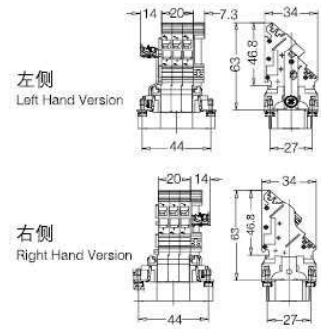

母插芯 螺钉连接 Female Inserts Screw Terminal



规格Size	描述Description	型号 Type	订货号 Part Number
6B	左侧 Left Hand Version	UTL-HE-006-F.AV.L	09330064726
6B	右侧 Right Hand Version	UTL-HE-006-F.AV.R	09330064736

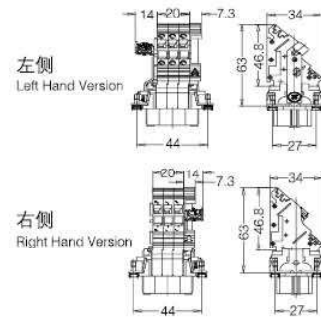

# Extendible Inserts

## UTL-HE AV 伸长型插芯 500V 16A 10+⊕

### 插芯 Inserts

外壳尺寸：匹配10B 不封底下壳外壳

Hoods/Housings: Matching 10B bulkhead mounting housings

公插芯 螺钉连接 Male Inserts Screw Terminal



规格Size	描述Description	型号 Type	订货号 Part Number
10B	左侧 Left Hand Version	UTL-HE-010-M.AV.L	09330104626
10B	右侧 Right Hand Version	UTL-HE-010-M.AV.R	09330104636

左侧  
Left Hand Version

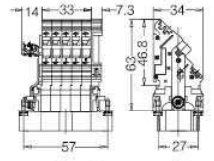

右侧  
Right Hand Version

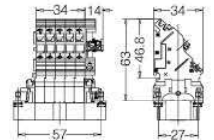

母插芯 螺钉连接 Female Inserts Screw Terminal



规格Size	描述Description	型号 Type	订货号 Part Number
10B	左侧 Left Hand Version	UTL-HE-010-F.AV.L	09330104726
10B	右侧 Right Hand Version	UTL-HE-010-F.AV.R	09330104736

左侧  
Left Hand Version

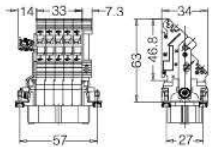

右侧  
Right Hand Version

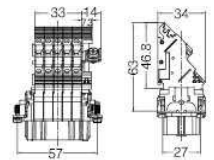

# Extendible Inserts

## UTL-HE AV 伸长型插芯 500V 16A 16+⊕

### 插芯 Inserts

外壳尺寸：匹配16B不封底下壳外壳

Hoods/Housings: Matching 16B bulkhead mounting housings

公插芯 螺钉连接 Male Inserts Screw Terminal



规格Size	描述Description	型号 Type	订货号 Part Number
16B	左侧 Left Hand Version	UTL-HE-016-M.AV.L	09330164626
16B	右侧 Right Hand Version	UTL-HE-016-M.AV.R	09330164636

规格Size	描述Description	型号 Type	订货号 Part Number
6B	左侧 Left Hand Version	UTL-HE-006-M.AV.L	09330064626
6B	右侧 Right Hand Version	UTL-HE-006-M.AV.R	09330064636

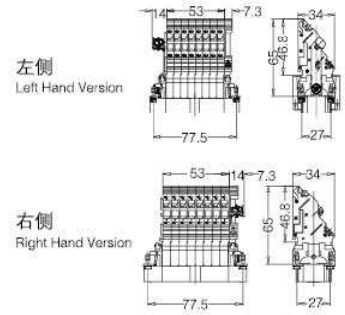

母插芯 螺钉连接 Female Inserts Screw Terminal



规格Size	描述Description	型号 Type	订货号 Part Number
16B	左侧 Left Hand Version	UTL-HE-016-F.AV.L	09330164726
16B	右侧 Right Hand Version	UTL-HE-016-F.AV.R	09330164736

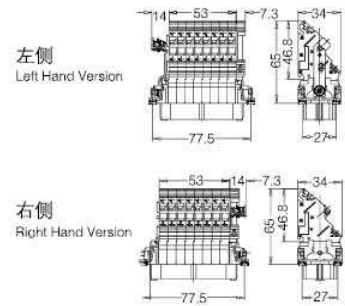

# Extendible Inserts

## UTL-HE AV 伸长型插芯 500V 16A 24+⊕

### 插芯 Inserts

外壳尺寸：匹配24B 不封底下壳外壳  
Hoods/Housings: Matching 24B bulkhead mounting housings

公插芯 螺钉连接 Male Inserts Screw Terminal

规格Size	描述Description	型号 Type	订货号 Part Number
24B	左侧 Left Hand Version	UTL-HE-024-M.AV.L	09330244626
24B	右侧 Right Hand Version	UTL-HE-024-M.AV.R	09330244636



左侧  
Left Hand Version

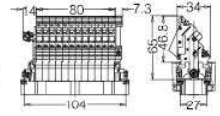

右侧  
Right Hand Version

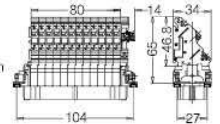

母插芯 螺钉连接 Female Inserts Screw Terminal

规格Size	描述Description	型号 Type	订货号 Part Number
24B	左侧 Left Hand Version	UTL-HE-024-F.AV.L	09330244726
24B	右侧 Right Hand Version	UTL-HE-024-F.AV.R	09330244736



左侧  
Left Hand Version

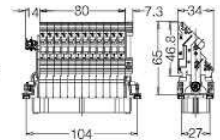

右侧  
Right Hand Version

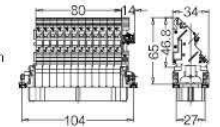

# UTL-HM 系列 / HM SERIES

灵活多变的模块组合型连接器 / Flexible and combined connector

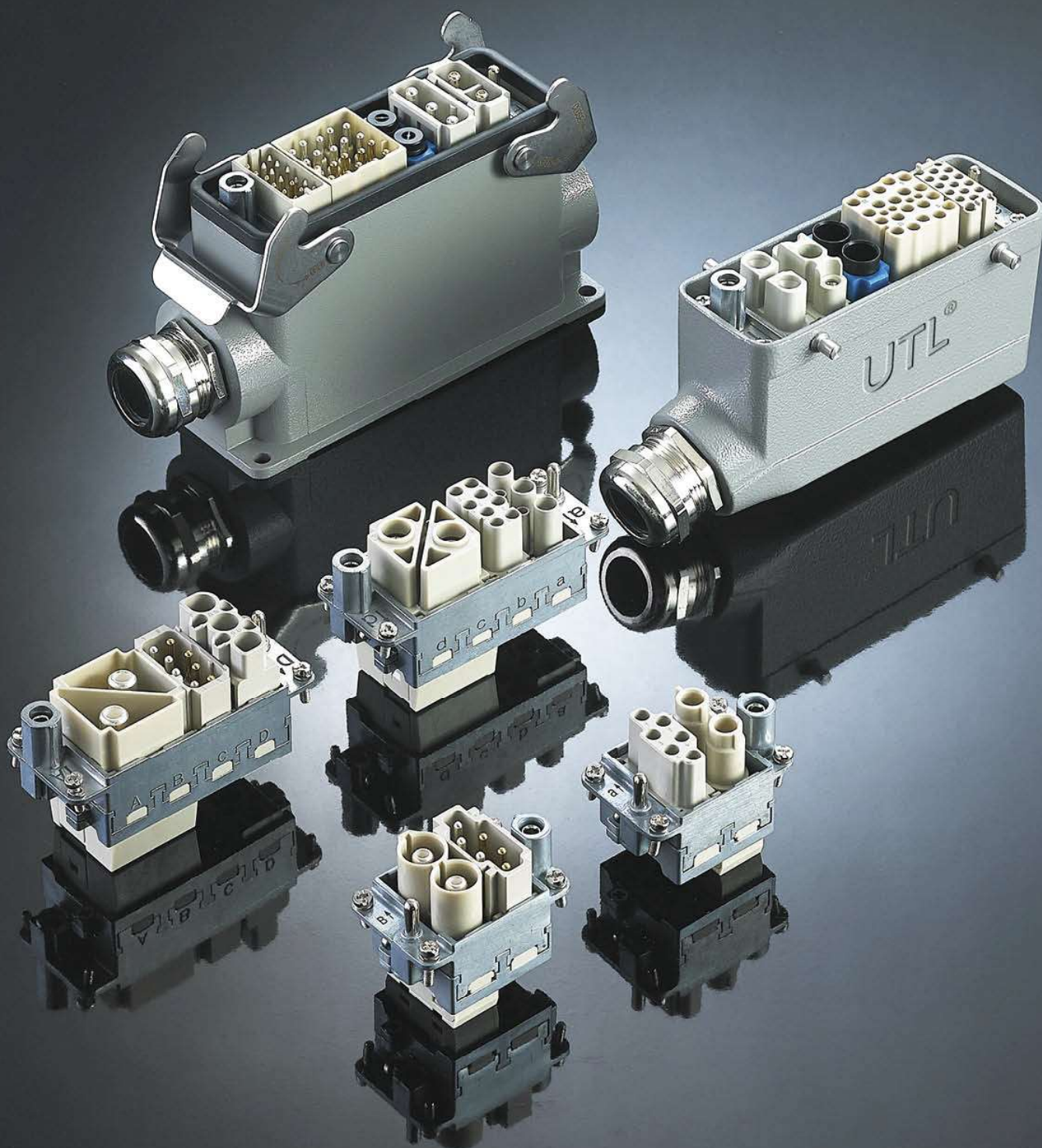

# Summary

## UTL-HM 章节概要

### 模块一览 Module list

尺寸 Unit: 单位



UTL-H2MK-001-M  
UTL-H2MK-001-F

插芯 Insert	200A 轴向压接型模块 200A Axial module
插针数 Contacts	1
连接方式 Terminal	轴向螺栓连接 Axial screw terminal
额定电流 Rated current	200A
额定电压 Rated voltage	1000V
线径 Wire gauge	25-70mm <sup>2</sup>



UTL-H2MK-001-MC  
UTL-H2MK-001-FC

插芯 Insert	200A 冷压型模块 200A Crimp mod
插针数 Contacts	1
连接方式 Terminal	冷压连接 Crimp terminal
额定电流 Rated current	200A
额定电压 Rated voltage	1000V
线径 Wire gauge	25-70mm <sup>2</sup>



UTL-HMK-001-MC  
UTL-HMK-001-FC

插芯 Insert	100A 冷压型模块 100A Crimp module
插针数 Contacts	1
连接方式 Terminal	冷压连接 Crimp terminal
额定电流 Rated current	100A
额定电压 Rated voltage	830V
线径 Wire gauge	10-35mm <sup>2</sup>



UTL-H2MK-002-M  
UTL-H2MK-002-F

插芯 Insert	100A 轴向压接型模块 100A Axial modu
插针数 Contacts	2
连接方式 Terminal	轴向螺栓连接 Axial screw term
额定电流 Rated current	100A
额定电压 Rated voltage	1000V
线径 Wire gauge	10-35mm <sup>2</sup>



UTL-H2MK-002-MC  
UTL-H2MK-002-FC

插芯 Insert	100A 冷压型模块 100A Crimp module
插针数 Contacts	2
连接方式 Terminal	冷压连接 Crimp terminal
额定电流 Rated current	100A
额定电压 Rated voltage	1000V
线径 Wire gauge	10-35mm <sup>2</sup>



UTL-HMK70-002-M  
UTL-HMK70-002-F

插芯 Insert	70A 冷压型模块 70A Axial modul
插针数 Contacts	2
连接方式 Terminal	轴向螺栓连接 Axial screw termi
额定电流 Rated current	70A
额定电压 Rated voltage	1000V
线径 Wire gauge	6-22mm <sup>2</sup>



UTL-HMK70-002-MC  
UTL-HMK70-002-FC

插芯 Insert	70A 冷压型模块 70A Crimp module
插针数 Contacts	2
连接方式 Terminal	冷压连接 Crimp terminal
额定电流 Rated current	70A
额定电压 Rated voltage	1000V
线径 Wire gauge	10-25mm <sup>2</sup>



UTL-HMK-002-M  
UTL-HMK-002-F

插芯 Insert	40A 轴向压接型模块 40A Axial modul
插针数 Contacts	2
连接方式 Terminal	轴向螺栓连接 Axial screw termi
额定电流 Rated current	40A
额定电压 Rated voltage	1000V
线径 Wire gauge	2.5-10mm <sup>2</sup>



UTL-HMK-002-MC  
UTL-HMK-002-FC

插芯 Insert	40A 冷压型模块 40A Crimp module
插针数 Contacts	2
连接方式 Terminal	冷压连接 Crimp terminal
额定电流 Rated current	40A
额定电压 Rated voltage	1000V
线径 Wire gauge	1.5-10mm <sup>2</sup>



UTL-HMK-003-M  
UTL-HMK-003-F

插芯 Insert	40A 轴向压接型模块 40A Axial modul
插针数 Contacts	3
连接方式 Terminal	轴向螺栓连接 Axial screw term
额定电流 Rated current	40A
额定电压 Rated voltage	690V
线径 Wire gauge	2.5-10mm <sup>2</sup>



UTL-HMK-003-MC  
UTL-HMK-003-FC

插芯 Insert	40A 冷压型模块 40A Crimp module
插针数 Contacts	3
连接方式 Terminal	冷压连接 Crimp terminal
额定电流 Rated current	40A
额定电压 Rated voltage	500V
线径 Wire gauge	1.5-10mm <sup>2</sup>



UTL-HMK-003/4-MC  
UTL-HMK-003/4-FC

插芯 Insert	40/10A 冷压型模块 40/10A Crimp mod
插针数 Contacts	3/4
连接方式 Terminal	冷压连接 Crimp terminal
额定电流 Rated current	40A/10A
额定电压 Rated voltage	830V
线径 Wire gauge	1.5-6mm <sup>2</sup> /0.37-2.5

# Summary

## UTL-HM 章节概要

### 结构框架类型 Construction Frame Version

尺寸 Unit: 单位mm



UTL-HMK-004-MC  
UTL-HMK-004-FC

插芯 Insert	40A 冷压型模块 40A Crimp module
插针数 Contacts	4
连接方式 Terminal	冷压连接 Crimp terminal
额定电流 Rated current	40A
额定电压 Rated voltage	830V
线径 Wire gauge	1.5-6mm <sup>2</sup>



UTL-HME-005-MS  
UTL-HME-005-FS

插芯 Insert	16A 弹片型模块 16A Cage-clamp module
插针数 Contacts	5
连接方式 Terminal	笼式弹片连接 Cage clamp terminal
额定电流 Rated current	16A
额定电压 Rated voltage	400V
线径 Wire gauge	0.14-2.5mm <sup>2</sup>



UTL-HME-006-MC  
UTL-HME-006-FC

插芯 Insert	16A 冷压型模块 16A Crimp module
插针数 Contacts	6
连接方式 Terminal	冷压连接 Crimp terminal
额定电流 Rated current	16A
额定电压 Rated voltage	500V
线径 Wire gauge	0.14-4mm <sup>2</sup>



UTL-HVME-006-MC  
UTL-HVME-006-FC

插芯 Insert	16A 防护型模块 16A Protected module
插针数 Contacts	6
连接方式 Terminal	冷压连接 Crimp terminal
额定电流 Rated current	16A
额定电压 Rated voltage	830V
线径 Wire gauge	0.14-4mm <sup>2</sup>



UTL-HMEE-008-MC  
UTL-HMEE-008-FC

插芯 Insert	16A 冷压型模块 16A Crimp module
插针数 Contacts	8
连接方式 Terminal	冷压连接 Crimp terminal
额定电流 Rated current	16A
额定电压 Rated voltage	400V
线径 Wire gauge	0.14-4mm <sup>2</sup>



UTL-H2MEE-020-MC  
UTL-H2MEE-020-FC

插芯 Insert	16A 冷压型模块 16A Crimp module
插针数 Contacts	20
连接方式 Terminal	冷压连接 Crimp terminal
额定电流 Rated current	16A
额定电压 Rated voltage	500V
线径 Wire gauge	0.14-4mm <sup>2</sup>



UTL-HMD-012-MC  
UTL-HMD-012-FC

插芯 Insert	10A 冷压型模块 10A Crimp module
插针数 Contacts	12
连接方式 Terminal	冷压连接 Crimp terminal
额定电流 Rated current	10A
额定电压 Rated voltage	250V
线径 Wire gauge	0.14-2.5mm <sup>2</sup>



UTL-HMDD-017-MC  
UTL-HMDD-017-FC

插芯 Insert	10A 冷压型模块 10A Crimp module
插针数 Contacts	17
连接方式 Terminal	冷压连接 Crimp terminal
额定电流 Rated current	10A
额定电压 Rated voltage	160V
线径 Wire gauge	0.14-2.5mm <sup>2</sup>



UTL-HMDS-009-MC  
UTL-HMDS-009-FC

插芯 Insert	5A D-Sub模块 5A D-Sub module
插针数 Contacts	9
连接方式 Terminal	冷压连接 Crimp terminal
额定电流 Rated current	5A
额定电压 Rated voltage	50V
线径 Wire gauge	0.09-0.82mm <sup>2</sup>



UTL-HMDS-025-MC  
UTL-HMDS-025-FC

插芯 Insert	4A 高密度型模块 4A High Density module
插针数 Contacts	25
连接方式 Terminal	冷压连接 Crimp terminal
额定电流 Rated current	4A
额定电压 Rated voltage	50V
线径 Wire gauge	0.09-0.52mm <sup>2</sup>



UTL-HM-RJ45-M  
UTL-HM-RJ45-F

插芯 Insert	1A RJ45模块 1A RJ45 module
插针数 Contacts	8
连接方式 Terminal	用于接电缆 Module for patch cable
额定电流 Rated current	1A
额定电压 Rated voltage	50V
线径 Wire gauge	

气动模块 Pneumatic module	气动模块 Pneumatic module
2	3



HMP-002    Φ6 mm    HMP-003    Φ1.6 mm, Φ3.0 mm, Φ4.0 mm



# Hinged Frames

## UTL-HM 模块框架

### 结构框架类型 Construction Frame Version

尺寸 Unit: 单位mm

6B 活动框架 适用所有6B外壳 / 6B frame, size 6B hoods/housings



描述 Description	标示Marking	型号 Type	订货号 Part Number
用于2个模块 for 2 modules	A-B	UTL-HF6B-NUA	09140060303
用于2个模块 for 2 modules	a-b	UTL-HF6B-NLA	09140060313

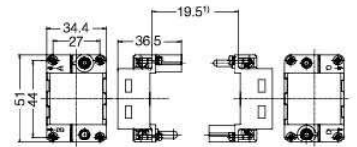

10B 活动框架 适用所有10B外壳 / 10B frame, size 10B hoods/housings



描述 Description	标示Marking	型号 Type	订货号 Part Number
用于3个模块 for 3 modules	A-C	UTL-HF10B-NUA	09140100303
用于3个模块 for 3 modules	a-c	UTL-HF10B-NLA	09140100313

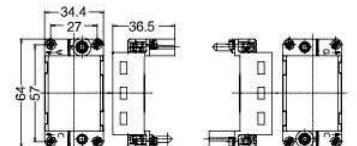

16B 活动框架 适用所有16B外壳 / 16B frame, size 16B hoods/housings



描述 Description	标示Marking	型号 Type	订货号 Part Number
用于4个模块 for 4 modules	A-D	UTL-HF16B-NUA	09140160303
用于4个模块 for 4 modules	a-d	UTL-HF16B-NLA	09140160313

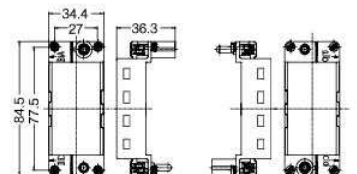

24B 活动框架 适用所有24B外壳 / 24B frame, size 24B hoods/housings



描述 Description	标示Marking	型号 Type	订货号 Part Number
用于6个模块 for 6 modules	A-F	UTL-HF24B-NUA	09140240303
用于6个模块 for 6 modules	a-f	UTL-HF24B-NLA	09140240313

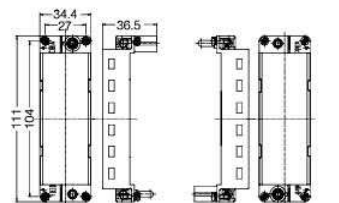

空置模块 / Filling module



描述 Description	型号 Type	订货号 Part Number
用于填充固定框架内剩余的模块空间	UTL-HM-000	09140009950

### 模块拆装示意图 Modules Dismounting Instructions

装配示意图 Assembly instructions

拆卸过程反之 Disassembly process is on the contrary.



装配前松开滑动边框  
Loosen sliding border before assembly



装配好模块后, 闭合滑动边框, 锁上螺丝  
After finished assembly, close sliding border, lock screw

# Axial Module

## UTL-H2MK-001 轴向压接型模块 1000V 200A

### 插芯 Inserts



可与框架及其他所有模块产品组合使用  
Combination with hinged frame and other modules possible.

### 技术参数 Technical Characteristics

规范	Specifications	
规范	Specifications	DIN EN 60 664 DIN EN 61 984
插芯	Inserts	
接插件针数	Number Of Contacts	1
依据 EN 61 984 的电气数据	Electrical Data Acc. To EN 61 984	
- 额定电流	- Rated Current	200A
- 额定电压	- Rated Voltage	1000V
- 额定脉冲电压	- Rated Impulse Voltage	8kV
- 污染程度	- Pollution Degree	3
依据 UL/CSA 额定电压	Rated Voltage Acc.to UI CSA	600V
绝缘电阻	Insulation Resistance	$\geq 10^{10} \Omega$
材料	Material	聚碳酸酯 Polycarbonate
工作温度范围	Limiting Temperatures	-40°C...+125°C
依据 UL 94 的阻燃等级	Flammability Acc. To UI94	V0
可接插次数	Mechanical Working Life-mating Cycles	$\geq 500$
插针	Contacts	
材料	Material	铜合金 Copper Alloy
表面处理	Surface	镀银 Hard-silver Plated
接触电阻	Contact Resistance	0.2m $\Omega$
电缆绞线依据 IEC 60 228-5	To IEC 60 228 Class 5	
轴向螺栓连接	Axial Screw Terminal	
- mm <sup>2</sup>	- mm <sup>2</sup>	25-70mm <sup>2</sup>
- AWG	- AWG	2-0
- 内六角扳手	- Hexagonal Driver	SW 5
- 剥线长度	- Stripping length	16mm
- 拧紧力矩	- Tightening Torque	
- mm <sup>2</sup>	- mm <sup>2</sup>	25 35 50 70
- Nm	- Nm	8 8 9 10

### 电流负载能力 Current Carrying Capacity

电流负载能力所受的限制主要来自包含接插针的接插体可承受的最大温度  
测试和控制过程依据 DIN EN 60512-5  
The current carrying is limited by maximum temperature of materials for Inserts and contacts including terminals.  
Measuring and testing techniques according to DIN EN 60512-

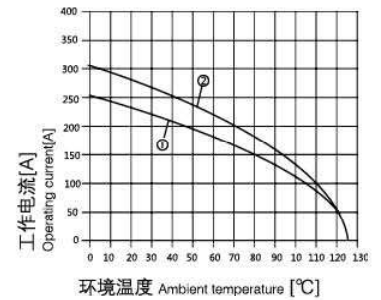

- ① 24B 外壳带3个模块，导线截面：50mm<sup>2</sup>  
② 24D 外壳带3个模块，导线截面：70mm<sup>2</sup>  
① 24 B hoods/housings with 3 modules, wire gauge:50mm<sup>2</sup>  
② 24 D hoods/housings with 3 modules, wire gauge:70mm<sup>2</sup>

### 轴向螺栓连接 Axial Screw Terminal



插芯 Inserts	型号 Type	订货号 Part Number
公 Male	UTL-H2MK-001.1-M(25-40mm <sup>2</sup> )	09140012663
	UTL-H2MK-001.2-M(40-70mm <sup>2</sup> )	09140012662
母 Female	UTL-H2MK-001.1-F(25-40mm <sup>2</sup> )	09140012763
	UTL-H2MK-001.2-F(40-70mm <sup>2</sup> )	09140012762

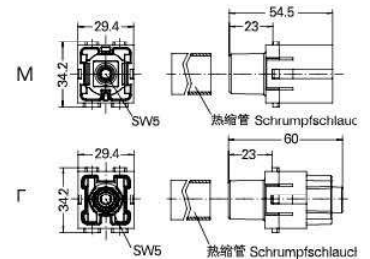

### 附件 Accessories

#### 工具 Tools

内六角扳手  
Hexagonal driver



描述 Description	型号 Type	订货号 Part Number
用于轴向夹紧螺栓 带T型把手 For Axial Setscrew With Grip	SW-5x150	09990000364

# Crimp Module

## UTL-H2MK-001 冷压型模块 1000V 200A

### 插芯 Inserts



可与框架及其他所有模块产品组合使用  
Combination with hinged frame and other modules possible.

### 技术参数 Technical Characteristics

规范	Specifications	
规范	Specifications	DIN EN 60 664
		DIN EN 61 984
插芯	Inserts	
接插件针数	Number Of Contacts	1
依据 EN 61 984 的电气数据	Electrical Data Acc. To EN 61 984	
- 额定电流	- Rated Current	200A
- 额定电压	- Rated Voltage	1000V
- 额定脉冲电压	- Rated Impulse Voltage	8kV
- 污染程度	- Pollution Degree	3
绝缘电阻	Insulation Resistance	$\geq 10^{10} \Omega$
材料	Material	聚碳酸酯 Polycarbonate
工作温度范围	Limiting Temperatures	-40°C...+125°C
依据 UL 94 的阻燃等级	Flammability Acc. To UL94	V0
可拔插次数	Mechanical Working Life-mating Cycles	$\geq 500$
插针	Contacts	
材料	Material	铜合金 Copper Alloy
表面处理	Surface	镀银 Hard-silver Plated
接触电阻	Contact Resistance	$\leq 0.3m\Omega$
冷压连接	Crimp Terminal	
- mm <sup>2</sup>	- mm <sup>2</sup>	25-70mm <sup>2</sup>
剥线长度	Stripping length	22.5mm
最大电缆直径	Max. insulation diameter	18mm

### 电流负载能力 Current Carrying Capacity

电流负载能力所受的限制主要来自包含接插针的接插体可承受的最大温度  
测试和控制过程依据 DIN EN 60512-5  
The current carrying is limited by maximum temperature of materials for Inserts and contacts including terminals.  
Measuring and testing techniques according to DIN EN 60512-5

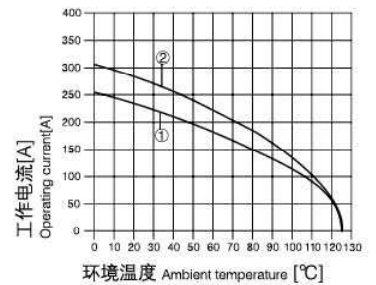

- ① 24B外壳带3个模块, 导线截面: 50mm<sup>2</sup>
- ② 24B外壳带3个模块, 导线截面: 70mm<sup>2</sup>
- ① 24 B hoods/housings with 3 modules, wire gauge: 50mm<sup>2</sup>
- ② 24 B hoods/housings with 3 modules, wire gauge: 70mm<sup>2</sup>

### 冷压连接 Crimp Terminal



插芯 Inserts	型号 Type	订货号 Part Number
公 Male	UTL-H2MK-001-MC	09140013001
母 Female	UTL-H2MK-001-FC	09140013101

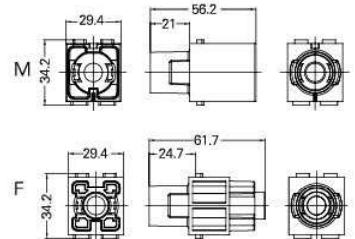

### 附件 Accessories

#### 200A 冷压针 Crimp contacts

接触电阻  $\leq 0.3 m\Omega$   
Contact resistance  $\leq 0.3 m\Omega$   
镀银 silver plated



公 Male	订货号 Part Number	母 Female	订货号 Part Number
CHSM200-25	09110006120	CHSF200-25	09110006220
CHSM200-35	09110006121	CHSF200-35	09110006221
CHSM200-50	09110006122	CHSF200-50	09110006222
CHSM200-70	09110006123	CHSF200-70	09110006223

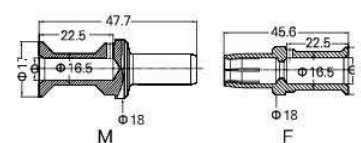

导线截面 Wire gauge	φ	剥线长度 Stripping length
25 mm <sup>2</sup>	7	22.5 mm
35 mm <sup>2</sup>	8.2	22.5 mm
50 mm <sup>2</sup>	10	22.5 mm
70 mm <sup>2</sup>	11.5	22.5 mm

电绞线依据 IEC 60 228-5  
for stranded wire according to IEC 60 228 Class 5

### 工具 Tools

液压钳  
Manual hydraulic clamp



压接线经 Wire gauge	型号 Type	订货号 Part Number
10-240mm <sup>2</sup>	TL05	09990000385

# Crimp Module

## UTL-HMK-001 冷压型模块 830V 100A

### 插芯 Inserts



可与框架及其他所有模块产品组合使用  
Combination with hinged frame and other modules possible.

### 技术参数 Technical Characteristics

规范	Specifications	
规范	Specifications	DIN EN 60 664
		DIN EN 61 984
插芯	Inserts	
接插件针数	Number Of Contacts	1
依据 EN 61 984的电气数据	Electrical Data Acc. To EN 61 984	
-额定电流	-Rated Current	100A
-额定电压	-Rated Voltage	830V
-额定脉冲电压	-Rated Impulse Voltage	8kV
-污染程度	-Pollution Degree	3
绝缘电阻	Insulation Resistance	$\geq 10^{10} \Omega$
材料	Material	聚碳酸酯 Polycarbonate
工作温度范围	Limiting Temperatures	-40°C...+125°C
依据UL 94的阻燃等级	Flammability Acc. To UI94	V0
可拔插次数	Mechanical Working Life-mating Cycles	$\geq 500$
最大电缆直径	Max. insulation diameter	13mm
插针	Contacts	
材料	Material	铜合金 Copper Alloy
表面处理	Surface	镀银 Hard-silver Plated
接触电阻	Contact Resistance	$\leq 0.3 m\Omega$
冷压连接	Crimp Terminal	
- mm <sup>2</sup>	- mm <sup>2</sup>	10-35mm <sup>2</sup>

### 冷压连接 Crimp Terminal



插芯 Inserts	型号 Type	订货号 Part Number
公 Male	UTL-HMK-001-MC	09140013003
母 Female	UTL-HMK-001-FC	09140013103

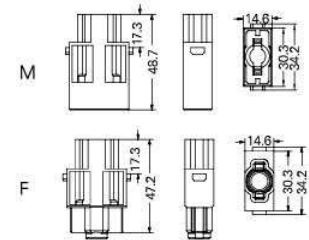

### 附件 Accessories

#### 100A 冷压针 Crimp contacts

接触电阻  $\leq 0.3 m\Omega$   
Contact resistance  $\leq 0.3 m\Omega$   
镀银 silver plated



公 Male	订货号 Part Number	母 Female	订货号 Part Number
CKSM-10	09110006114	CKSF-10G	09110006214
CKSM-16	09110006116	CKSF-16G	09110006216
CKSM-25	09110006125	CKSF-25G	09110006225
CKSM-35	09110006135	CKSF-35G	09110006235

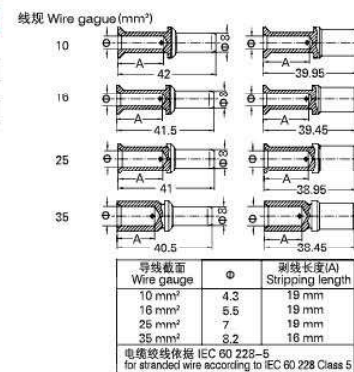

### 工具 Tools

液压钳  
Manual hydraulic clamp



压接导线 Wire gauge	型号 Type	订货号 Part Number
10-240mm <sup>2</sup>	TL05	09990000385

退针器  
Removal tool



适用类型 For	型号 Type	订货号 Part Number
100A 冷压针 Crimp contacts	TL11	09990000383

# Axial Module

## UTL-H2MK-002 轴向压接型模块 1000V 100A

### 插芯 Inserts



可与框架及其他所有模块产品组合使用

Combination with hinged frame and other modules possible.

### 技术参数 Technical Characteristics

规范	Specifications	
规范	Specifications	DIN EN 60 664
		DIN EN 61 984
插芯	Inserts	
接插件针数	Number Of Contacts	2
依据 EN 61 984 的电气数据	Electrical Data Acc. To EN 61 984	
- 额定电流	- Rated Current	100A
- 额定电压	- Rated Voltage	1000V
- 额定脉冲电压	- Rated Impulse Voltage	8kV
- 污染程度	- Pollution Degree	3
依据 UL 的额定电压	Rated Voltage Acc. to UL	600V
绝缘电阻	Insulation Resistance	$\geq 10^{10} \Omega$
材料	Material	聚碳酸酯 Polycarbonate
工作温度范围	Limiting Temperatures	-40°C...+125°C
依据 UL 94 的阻燃等级	Flammability Acc. To UL94	V0
可拔插次数	Mechanical Working Life-mating Cycles	$\geq 500$
插针	Contacts	
材料	Material	铜合金 Copper Alloy
表面处理	Surface	镀银 Hard-silver Plated
接触电阻	Contact Resistance	0.3m $\Omega$
电缆绞线依据 IEC 60 228-5	To IEC 60 228 Class 5	
轴向螺栓连接	Axial Screw Terminal	
- mm <sup>2</sup>	- mm <sup>2</sup>	10-38mm <sup>2</sup>
- AWG	- AWG	6-2
- 内六角扳手	- Hexagonal Driver	SW 4
- 剥线长度	- Stripping length	13mm
- 拧紧力矩	- Tightening Torque	
- mm <sup>2</sup>	- mm <sup>2</sup>	10 16 25 35
- Nm	- Nm	6 6 7 8

### 电流负载能力 Current Carrying Capacity

电流负载能力所受的限制主要来自包含接插针的接插体可承受的最大温度  
测试和控制过程依据 DIN EN 60512-5  
The current carrying is limited by maximum temperature of materials for inserts and contacts including terminals.  
Measuring and testing techniques according to DIN EN 60512-5

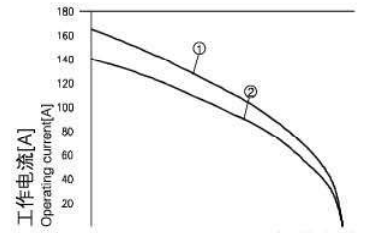

环境温度 Ambient temperature [°C]

- ① 24B外壳带3个模块，导线截面：35mm<sup>2</sup>
- ② 24B外壳带3个模块，导线截面：25mm<sup>2</sup>
- ① 24 B hoods/housings with 3 modules, wire gauge:35mm<sup>2</sup>
- ② 24 B hoods/housings with 3 modules, wire gauge:25mm<sup>2</sup>

### 轴向螺栓连接 Axial Screw Terminal



插芯 Inserts	型号 Type	订货号 Part Number
公 Male	UTL-H2MK-002.1-M(10-25mm <sup>2</sup> )	09140022653
	UTL-H2MK-002.2-M(16-35mm <sup>2</sup> )	09140022651
	UTL-H2MK-002.1-M(38mm <sup>2</sup> )	09140022650
母 Female	UTL-H2MK-002.1-F(10-25mm <sup>2</sup> )	09140022753
	UTL-H2MK-002.2-F(16-35mm <sup>2</sup> )	09140022751
	UTL-H2MK-002.1-F(38mm <sup>2</sup> )	09140022750

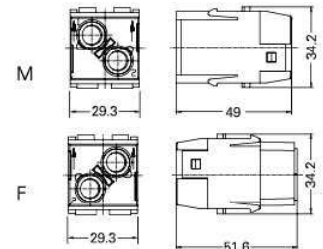

### 附件 Accessories

#### 电缆终端 Cable shoe 16mm<sup>2</sup>



描述 Description	型号 Type	订货号 Part Number
用于PE扩展 For PE extension	PE-E16	09140009912

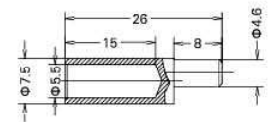

#### 工具 Tools

#### 内六角扳手 Hexagonal driver



描述 Description	型号 Type	订货号 Part Number
用于轴向夹紧螺栓 带T型把手 For Axial Setscrew With Grip	SW-4x100	09990000363

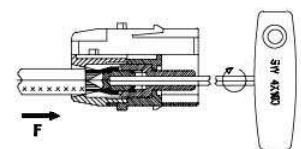

# Crimp Module

## UTL-HMK70-002 冷压型模块 1000V 70A

### 插芯 Inserts



可与框架及其他所有模块产品组合使用  
Combination with hinged frame and other modules possible.

### 技术参数 Technical Characteristics

规范	Specifications	
规范	Specifications	DIN EN 60 664 DIN EN 61 984
插芯	Inserts	
接插件针数	Number Of Contacts	2
依据 EN 61 984 的电气数据	Electrical Data Acc. To EN 61 984	
-额定电流	-Rated Current	70A
-额定电压	-Rated Voltage	1000V
-额定脉冲电压	-Rated Impulse Voltage	8kV
-污染程度	-Pollution Degree	3
绝缘电阻	Insulation Resistance	$\geq 10^{10} \Omega$
材料	Material	聚碳酸酯 Polycarbonate
工作温度范围	Limiting Temperatures	-40°C...+125°C
依据UL 94的阻燃等级	Flammability Acc. To UI94	V0
可拔插次数	Mechanical Working Life-mating Cycles	$\geq 500$
插针	Contacts	
材料	Material	铜合金 Copper Alloy
表面处理	Surface	镀银 Hard-silver Plated
接触电阻	Contact Resistance	$\leq 0.5m\Omega$
冷压连接	Crimp Terminal	
- mm <sup>2</sup>	- mm <sup>2</sup>	10-25mm <sup>2</sup>
剥线长度	Stripping length	15.5mm
最大电缆直径	Max. insulation diameter	11mm

#### 冷压连接 Crimp Terminal



插芯 Inserts	型号 Type	订货号 Part Number
公 Male	UTL-HMK70-002-MC	09140022761
母 Female	UTL-HMK70-002-FC	09140022762

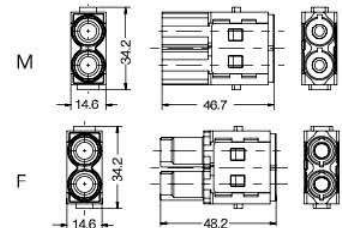

### 附件 Accessories

#### 70A 冷压针 Crimp contacts

接触电阻  $\leq 0.5 m\Omega$   
Contact resistance  $\leq 0.5 m\Omega$   
镀银 silver plated



公 Male	订货号 Part Number	母 Female	订货号 Part Number
CKSM70-10	09320007104	CKSF70-10	09320007204
CKSM70-16	09320007105	CKSF70-16	09320007205
CKSM70-25	09320007106	CKSF70-25	09320007206

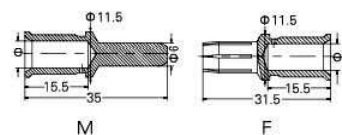

导线截面 Wire gauge	Φ	剥线长度 Stripping length
10 mm <sup>2</sup>	4.3	15.5 mm
16 mm <sup>2</sup>	5.5	15.5 mm
25 mm <sup>2</sup>	7	15.5 mm

电缆绞线依据 IEC 60 228-5  
for stranded wire according to IEC 60 228 Class 5

#### 工具 Tools

液压钳  
Manual hydraulic clamp



压接导线 Wire gauge	型号 Type	订货号 Part Number
10-240mm <sup>2</sup>	TL05	09990000385

# Axial Module

## UTL-HMK-002 轴向压接型模块 1000V 40A

### 插芯 Inserts



可与框架及其他所有模块产品组合使用  
Combination with hinged frame and other modules possible.

### 技术参数 Technical Characteristics

规范	Specifications	
规范	Specifications	DIN EN 60 664
		DIN EN 61 984
插芯	Inserts	
接插件针数	Number Of Contacts	2
依据 EN 61 984的电气数据	Electrical Data Acc. To EN 61 984	
- 额定电流	- Rated Current	40A
- 额定电压	- Rated Voltage	1000V
- 额定脉冲电压	- Rated Impulse Voltage	8kV
- 污染程度	- Pollution Degree	3
依据UL的额定电压	Rated Voltage Acc.to UI	600V
绝缘电阻	Insulation Resistance	$\geq 10^{10}\Omega$
材料	Material	聚碳酸酯 Polycarbonate
工作温度范围	Limiting Temperatures	-40°C...+125°C
依据UL 94的阻燃等级	Flammability Acc. To UI94	V0
可拔插次数	Mechanical Working Life-mating Cycles	$\geq 500$
插针	Contacts	
材料	Material	铜合金 Copper Alloy
表面处理	Surface	镀银 Hard-silver Plated
接触电阻	Contact Resistance	0.5m $\Omega$
电缆绞线依据IEC 60 228-5	To IEC 60 228 Class 5	
轴向螺栓连接	Axial Screw Terminal	
- mm <sup>2</sup>	- mm <sup>2</sup>	2.5-10mm <sup>2</sup>
- AWG	- AWG	14-8
- 内六角扳手	- Hexagonal Driver	SW 2
- 剥线长度	- Stripping length	
- mm <sup>2</sup>	- mm <sup>2</sup>	2.5 4 6 10
- mm	- mm	5 <sup>1</sup> 5 <sup>1</sup> 8 <sup>1</sup> 11 <sup>1</sup>
- 拧紧力矩	- Tightening Torque	
- mm <sup>2</sup>	- mm <sup>2</sup>	2.5 4 6 10
- Nm	- Nm	1.5 1.5 2 2

### 电流负载能力 Current Carrying Capacity

电流负载能力所受的限制主要来自包含接插针的接插体可承受的最大温度  
测试和控制过程依据 DIN EN 60512-5  
The current carrying is limited by maximum temperature of materials for inserts and contacts including terminals.  
Measuring and testing techniques according to DIN EN 60512-5

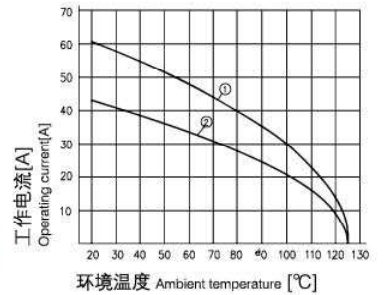

- ① 24B外壳带6个模块，导线截面：10mm<sup>2</sup>
- ② 24B外壳带6个模块，导线截面：6mm<sup>2</sup>
- ① 24 B hoods/housings with 6 modules, wire gauge:10mm<sup>2</sup>
- ② 24 B hoods/housings with 6 modules, wire gauge:6mm<sup>2</sup>

### 轴向螺栓连接 Axial Screw Terminal



插芯 Inserts	型号 Type	订货号 Part Number
公 Male	UTL-HMK-002.1-M(2.5-8mm <sup>2</sup> )	09140022601
	UTL-HMK-002.2-M(6-10mm <sup>2</sup> )	09140022602
母 Female	UTL-HMK-002.1-F(2.5-8mm <sup>2</sup> )	09140022701
	UTL-HMK-002.2-F(6-10mm <sup>2</sup> )	09140022702

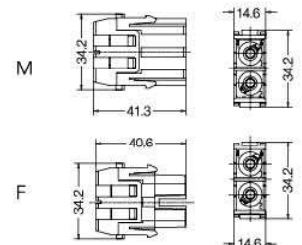

### 附件 Accessories

#### 工具 Tools

内六角扳手  
Hexagonal driver



描述 Description	型号 Type	订货号 Part Number
用于轴向夹紧螺栓 带T型把手 For Axial Setscrew With Grip	SW-2x40	09990000313

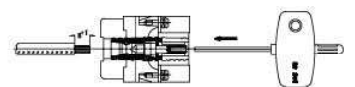

# Crimp Module

## UTL-HMK70-002 冷压型模块 1000V 40A

### 插芯 Inserts



可与框架及其他所有模块产品组合使用  
Combination with hinged frame and other modules possible.

### 技术参数 Technical Characteristics

规范	Specifications	
规范	Specifications	DIN EN 60 664
		DIN EN 61 984
插芯	Inserts	
接插件针数	Number Of Contacts	2
依据 EN 61 984 的电气数据	Electrical Data Acc. To EN 61 984	
-额定电流	-Rated Current	40A
-额定电压	-Rated Voltage	1000V
-额定脉冲电压	-Rated Impulse Voltage	8kV
-污染程度	-Pollution Degree	3
绝缘电阻	Insulation Resistance	$\geq 10^{10} \Omega$
材料	Material	聚碳酸酯 Polycarbonate
工作温度范围	Limiting Temperatures	-40°C...+125°C
依据UL 94 的阻燃等级	Flammability Acc. To UI94	V0
可拔插次数	Mechanical Working Life-mating Cycles	$\geq 500$
插针	Contacts	
材料	Material	铜合金 Copper Alloy
表面处理	Surface	镀银 Hard-silver Plated
接触电阻	Contact Resistance	$\leq 0.3m\Omega$
冷压连接	Crimp Terminal	
- mm <sup>2</sup>	- mm <sup>2</sup>	1.5-10mm <sup>2</sup>
-AWG	-AWG	16-8

### 电流负载能力 Current Carrying Capacity

电流负载能力所受的限制主要来自包含接插针的接插体可承受的最大温度  
测试和控制过程依据 DIN EN 60512-5  
The current carrying is limited by maximum temperature of materials for inserts and contacts including terminals.  
Measuring and testing techniques according to DIN EN 60512-5

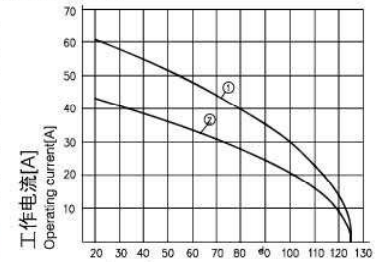

- ① 24B外壳带6个模块, 导线截面: 10mm<sup>2</sup>  
② 24B外壳带6个模块, 导线截面: 6mm<sup>2</sup>  
① 24 B hoods/housings with 6 modules, wire gauge: 10mm<sup>2</sup>  
② 24 B hoods/housings with 6 modules, wire gauge: 6mm<sup>2</sup>

### 冷压连接 Crimp Terminal



插芯 Inserts	型号 Type	订货号 Part Number
公 Male	UTL-HMK-002-MC	09140023002
母 Female	UTL-HMK-002-FC	09140023102

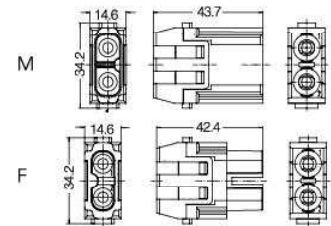

### 附件 Accessories

#### 40A 冷压针 Crimp contacts

接触电阻  $\leq 0.3 m\Omega$   
Contact resistance  $\leq 0.3 m\Omega$   
镀银 silver plated



公 Male	订货号 Part Number	母 Female	订货号 Part Number
CCSM-1.5	09320006104	CCSF-1.5	09320006204
CCSM-2.5	09320006105	CCSF-2.5	09320006205
CCSM-4.0	09320006107	CCSF-4.0	09320006207
CCSM-6.0	09320006108	CCSF-6.0	09320006208
CCSM-10.0	09320006109	CCSF-10.0	09320006209

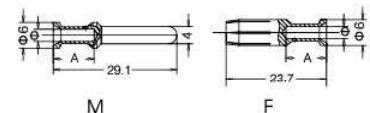

导线截面 Wire gauge	Φ	剥线长度 Stripping length
1.5 mm <sup>2</sup> AWG 18	1.75	9 mm
2.5 mm <sup>2</sup> AWG 14	2.25	9 mm
4 mm <sup>2</sup> AWG 12	2.85	9.6 mm
6 mm <sup>2</sup> AWG 10	3.5	9.6 mm
10 mm <sup>2</sup> AWG 8	4.3	15 mm

剥线长度A=15 mm用于电缆 $\geq 5$  mm  
剥线长度A=18 mm用于电缆 $\geq 6.4$  mm  
Stripping length A = 15 mm for cables  $\geq 5$  mm  
Stripping length A = 18 mm for cables  $\geq 6.4$  mm

### 工具 Tools

#### 冷压钳 Manual hydraulic



压接线径 Wire gauge	型号 Type	订货号 Part Number
1.5-6mm <sup>2</sup>	TL02-0G	09990000110
4/6/10mm <sup>2</sup>	TL02-3G	09990000303

#### 退针器 Removal tool



适用类型 For	型号 Type	订货号 Part Number
40A 冷压针 Crimp contacts	TL06	09990000305



# Axial Module

## UTL-HMK-003 轴向压接型模块 690V 40A

### 插芯 Inserts



可与框架及其他所有模块产品组合使用

Combination with hinged frame and other modules possible.

### 技术参数 Technical Characteristics

规范	Specifications	
规范	Specifications	DIN EN 60 664
		DIN EN 61 984
插芯	Inserts	
接插件针数	Number Of Contacts	3
依据 EN 61 984 的电气数据	Electrical Data Acc. To EN 61 984	
- 额定电流	- Rated Current	40A
- 额定电压	- Rated Voltage	690V
- 额定脉冲电压	- Rated Impulse Voltage	8kV
- 污染程度	- Pollution Degree	3
依据 UL 的额定电压	Rated Voltage Acc. to UI	600V
绝缘电阻	Insulation Resistance	$\geq 10^{10} \Omega$
材料	Material	聚碳酸酯 Polycarbonate
工作温度范围	Limiting Temperatures	-40°C...+125°C
依据 UL 94 的阻燃等级	Flammability Acc. To UI94	V0
可拔插次数	Mechanical Working Life-mating Cycles	$\geq 500$
插针	Contacts	
材料	Material	铜合金 Copper Alloy
表面处理	Surface	镀银 Hard-silver Plated
接触电阻	Contact Resistance	0.3m $\Omega$
电缆绞线依据 IEC 60 228-5	To IEC 60 228 Class 5	
轴向螺栓连接	Axial Screw Terminal	
- mm <sup>2</sup>	- mm <sup>2</sup>	2.5-10mm <sup>2</sup>
- AWG	- AWG	14-8
- 内六角扳手	- Hexagonal Driver	SW 2
- 剥线长度	- Stripping length	
- mm <sup>2</sup>	- mm <sup>2</sup>	2.5 4 6 10
- mm	- mm	5 <sup>1</sup> 5 <sup>1</sup> 8 <sup>1</sup> 11 <sup>1</sup>
- 拧紧力矩	- Tightening Torque	
- mm <sup>2</sup>	- mm <sup>2</sup>	2.5 4 6 10
- Nm	- Nm	1.5 1.5 2 2

### 电流负载能力 Current Carrying Capacity

电流负载能力所受的限制主要来自包含接插针的接插体可承受的最大温度  
测试和控制过程依据 DIN EN 60512-5  
The current carrying is limited by maximum temperature of materials for Inserts and contacts including terminals. Measuring and testing techniques according to DIN EN 60512-5

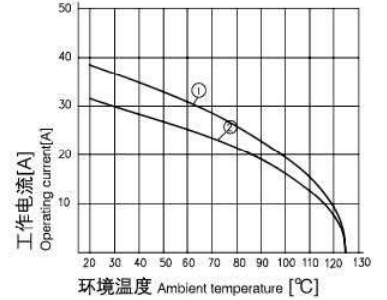

① 24B外壳带6个模块，导线截面：6mm<sup>2</sup>

② 24B外壳带6个模块，导线截面：4mm<sup>2</sup>

① 24 B hoods/housings with 6 modules, wire gauge: 6mm<sup>2</sup>

② 24 B hoods/housings with 6 modules, wire gauge: 4mm<sup>2</sup>

### 轴向螺栓连接 Axial Screw Terminal



插芯 Inserts	型号 Type	订货号 Part Number
公 Male	UTL-HMK-003.1-M(2.5-8mm <sup>2</sup> )	09140032601
	UTL-HMK-003.2-M(6-10mm <sup>2</sup> )	09140032602
母 Female	UTL-HMK-003.1-F(2.5-8mm <sup>2</sup> )	09140032701
	UTL-HMK-003.2-F(6-10mm <sup>2</sup> )	09140032702

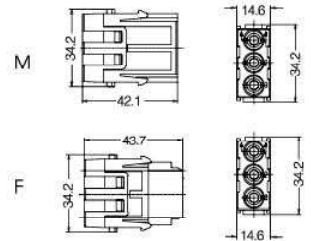

### 附件 Accessories

#### 工具 Tools

内六角扳手  
Hexagonal driver



描述 Description	型号 Type	订货号 Part Number
用于轴向夹紧螺栓 带T型把手 For Axial Setscrew With Grip	SW-2x40	09990000313

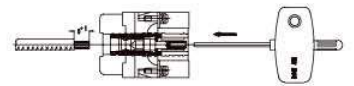

# Crimp Module

## UTL-HMK-003 冷压型模块 400/690V 40A

### 插芯 Inserts



可与框架及其他所有模块产品组合使用

Combination with hinged frame and other modules possible.

### 技术参数 Technical Characteristics

规范	Specifications	
规范	Specifications	DIN EN 60 664 DIN EN 61 984
插芯	Inserts	
接插件针数	Number Of Contacts	3
依据 EN 61 984 的电气数据	Electrical Data Acc. To EN 61 984	
-额定电流	-Rated Current	40A
-额定电压	-Rated Voltage	400/690V
-额定脉冲电压	-Rated Impulse Voltage	6kV
-污染程度	-Pollution Degree	3
依据UL/CSA的额定电压	Rated Voltage Acc. to UL/CSA	600V
依据UL/CSA的额定电流	Rated Current Acc. to UL/CSA	32A
绝缘电阻	Insulation Resistance	$\geq 10^{10} \Omega$
材料	Material	聚碳酸酯 Polycarbonate
工作温度范围	Limiting Temperatures	-40°C...+125°C
依据UL 94的阻燃等级	Flammability Acc. To UL94	V0
可拔插次数	Mechanical Working Life-mating Cycles	$\geq 500$
插针	Contacts	
材料	Material	铜合金 Copper Alloy
表面处理	Surface	镀银 Hard-silver Plated
接触电阻	Contact Resistance	$\leq 0.3m\Omega$
冷压连接	Crimp Terminal	
- mm <sup>2</sup>	- mm <sup>2</sup>	1.5-10mm <sup>2</sup>
-AWG	-AWG	16-8

### 电流负载能力 Current Carrying Capacity

电流负载能力所受的限制主要来自包含接插针的接插体可承受的最大温度

测试和控制过程依据 DIN EN 60512-5

The current carrying is limited by maximum temperature of materials for inserts and contacts including terminals. Measuring and testing techniques according to DIN EN 60512-5

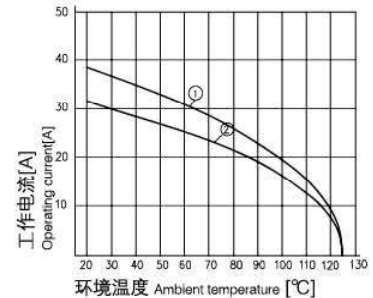

① 24B外壳带6个模块，导线截面：6mm<sup>2</sup>

② 24B外壳带6个模块，导线截面：4mm<sup>2</sup>

① 24 B hoods/housings with 6 modules, wire gauge:6mm<sup>2</sup>

② 24 B hoods/housings with 6 modules, wire gauge:4mm<sup>2</sup>

### 冷压连接 Crimp Terminal



插芯 Inserts	型号 Type	订货号 Part Number
公 Male	UTL-HMK-003-MC	09140033003
母 Female	UTL-HMK-003-FC	09140033103

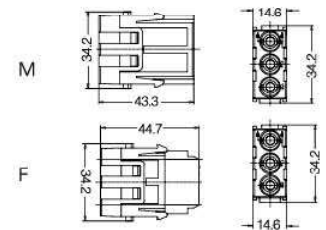

### 附件 Accessories

40A 冷压针 Crimp contacts

接触电阻  $\leq 0.3 m\Omega$

Contact resistance  $\leq 0.3 m\Omega$

镀银 silver plated



公 Male	订货号 Part Number	母 Female	订货号 Part Number
CCSM-1.5	09320006104	CCSF-1.5	09320006204
CCSM-2.5	09320006105	CCSF-2.5	09320006205
CCSM-4.0	09320006107	CCSF-4.0	09320006207
CCSM-6.0	09320006108	CCSF-6.0	09320006208
CCSM-10.0	09320006109	CCSF-10.0	09320006209

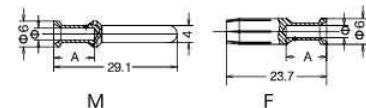

导线截面 Wire gauge	φ	剥线长度 Stripping length
1.5 mm <sup>2</sup>	AWG 16	1.75
2.5mm <sup>2</sup>	AWG 14	2.25
4 mm <sup>2</sup>	AWG 12	2.85
6 mm <sup>2</sup>	AWG 10	3.5
10 mm <sup>2</sup>	AWG 8	4.3
15 mm <sup>2</sup>	AWG 6	5.0

剥线长度A=15 mm用于电缆 $\geq 5$  mm  
剥线长度A=18 mm用于电缆 $\geq 6.4$  mm  
Stripping length A = 15 mm for cables  $\geq 5$  mm  
Stripping length A = 18 mm for cables  $\geq 6.4$  mm

### 工具 Tools

冷压钳

Manual hydraulic



压接线径 Wire gauge	型号 Type	订货号 Part Number
1.5-6mm <sup>2</sup>	TL02-0G	09990000110
4/6/10mm <sup>2</sup>	TL02-3G	09990000303

退针器

Removal tool



适用类型 For	型号 Type	订货号 Part Number
40A 冷压针 Crimp contacts	TL06	09990000305

# Crimp Module

## UTL-HMK-003/4 冷压型模块 830/830V 40/10A

### 插芯 Inserts



可与框架及其他所有模块产品组合使用  
Combination with hinged frame and other modules possible.

### 技术参数 Technical Characteristics

规范	Specifications	DIN EN 60 664
规范	Specifications	DIN EN 61 984
<b>插芯 Inserts</b>		
接插件针数	Number Of Contacts	3/4
依据 EN 61 984的电气数据 Electrical Data Acc. To EN 61 984		
电力区	Power Contacts	40A
- 额定电流	- Rated Current	830V
- 额定电压	- Rated Voltage	8kV
- 额定脉冲电压	- Rated Impulse Voltage	3
- 污染程度	- Pollution Degree	
信号区	Signal Contacts	
- 额定电流	- Rated Current	10A
- 额定电压	- Rated Voltage	830V
- 额定脉冲电压	- Rated Impulse Voltage	8kV
- 污染程度	- Pollution Degree	3
依据UL的额定电压	Rated Voltage Acc. to Ul	600V
绝缘电阻	Insulation Resistance	$\geq 10^{10} \Omega$
材料	Material	聚碳酸酯 Polycarbonate
工作温度范围	Limiting Temperatures	-40°C...+125°C
依据UL 94的阻燃等级	Flammability Acc. To Ul94	V0
可拔插次数	Mechanical Working Life-mating Cycles	$\geq 500$
<b>插针 Contacts</b>		
材料	Material	铜合金 Copper Alloy
表面处理	Surface	镀银 Hard-silver Plated 镀金 Hard-gold Plated
<b>接触电阻 Contact Resistance</b>		
- 电力区	Power Contacts	$\leq 0.3m \Omega$
- 信号区	Signal Contacts	$\leq 3m \Omega$
<b>冷压连接 Crimp terminal</b>		
- mm <sup>2</sup>	mm <sup>2</sup>	
- 电力区	Power Contacts	1.5-6mm <sup>2</sup>
- 信号区	Signal Contacts	0.14-2.5mm <sup>2</sup>
- AWG	AWG	
- 电力区	Power Contacts	16-10
- 信号区	Signal Contacts	26-14
<b>最大电缆直径 Max. insulation diameter</b>		
- 电力区	Power Contacts	5mm

### 电流负载能力 Current Carrying Capacity

电流负载能力所受的限制主要来自包含接插针的接插体可承受的最大温度  
测试和控制过程依据 DIN EN 60512-5  
The current carrying is limited by maximum temperature of materials for Inserts and contacts including terminals. Measuring and testing techniques according to DIN EN 60512-5

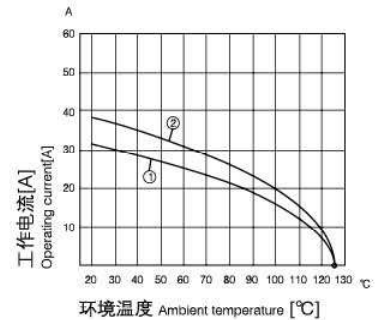

- ① 24B外壳带6个模块, 导线截面: 4mm<sup>2</sup>
- ② 24B外壳带6个模块, 导线截面: 6mm<sup>2</sup>
- ① 24 B hoods/housings with 6 modules, wire gauge:4mm<sup>2</sup>
- ② 24 B hoods/housings with 6 modules, wire gauge:6mm<sup>2</sup>

### 冷压连接 Crimp Terminal



插芯 Inserts	型号 Type	订货号 Part Number
公 Male	UTL-HMK-003/4-MC	09140073001
母 Female	UTL-HMK-003/4-FC	09140073101

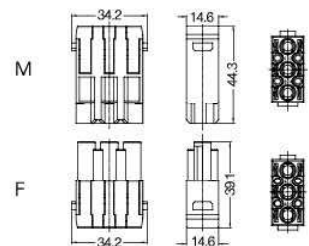

### 附件 Accessories

40A/10A 冷压针 Crimp contacts

接触电阻  $\leq 0.3 m \Omega$   
Contact resistance  $\leq 0.3 m \Omega$   
镀银 silver plated



公 Male	订货号 Part Number	母 Female	订货号 Part Number
CCSM-1.5	09320006104	CCSF-1.5	09320006204
CCSM-2.5	09320006105	CCSF-2.5	09320006205
CCSM-4.0	09320006107	CCSF-4.0	09320006207
CCSM-6.0	09320006108	CCSF-6.0	09320006208
CCSM-10.0	09320006109	CCSF-10.0	09320006209

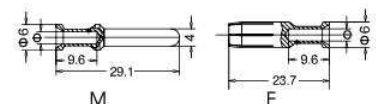

线规 Wire gauge	Φ	剥线长度 Stripping length
1.5 mm <sup>2</sup>	AWG 16	1.75
2.5 mm <sup>2</sup>	AWG 14	2.25
4 mm <sup>2</sup>	AWG 12	2.85
6 mm <sup>2</sup>	AWG 10	3.5

# Crimp Module

## UTL-HMK-004 冷压型模块 830V 40A

### 插芯 Inserts



可与框架及其他所有模块产品组合使用

Combination with hinged frame and other modules possible.

### 技术参数 Technical Characteristics

规范	Specifications	
规范	Specifications	DIN EN 60 664
		DIN EN 61 984
插芯	Inserts	
接插件针数	Number Of Contacts	4
依据 EN 61 984 的电气数据	Electrical Data Acc. To EN 61 984	
-额定电流	-Rated Current	40A
-额定电压	-Rated Voltage	830V
-额定脉冲电压	-Rated Impulse Voltage	8kV
-污染程度	-Pollution Degree	3
依据UL的额定电压	Rated Voltage Acc. to UL	600V
绝缘电阻	Insulation Resistance	$\geq 10^{10} \Omega$
材料	Material	聚碳酸酯 Polycarbonate
工作温度范围	Limiting Temperatures	-40°C...+125°C
依据UL 94的阻燃等级	Flammability Acc. To UI94	V0
可拔插次数	Mechanical Working Life-mating Cycles	$\geq 500$
插针	Contacts	
材料	Material	铜合金 Copper Alloy
表面处理	Surface	镀银 Hard-silver Plated
接触电阻	Contact Resistance	$\leq 0.3m\Omega$
冷压连接	Crimp Terminal	
- mm <sup>2</sup>	- mm <sup>2</sup>	1.5-6mm <sup>2</sup>
-AWG	-AWG	16-10

### 电流负载能力 Current Carrying Capacity

电流负载能力所受的限制主要来自包含接插针的接插体可承受的最大温度

测试和控制过程依据 DIN EN 60512-5

The current carrying is limited by maximum temperature of materials for Inserts and contacts including terminals. Measuring and testing techniques according to DIN EN 60512-5

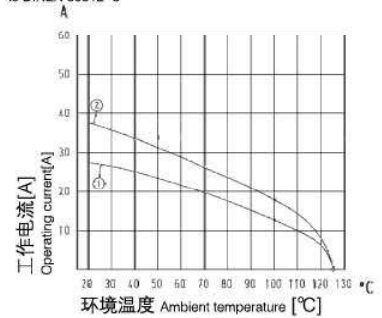

① 24B外壳带6个模块, 导线截面: 4mm<sup>2</sup>

② 24B外壳带6个模块, 导线截面: 6mm<sup>2</sup>

① 24 B hoods/housings with 6 modules, wire gauge:4mm<sup>2</sup>

② 24 B hoods/housings with 6 modules, wire gauge:6mm<sup>2</sup>

### 冷压连接 Crimp Terminal



插芯 Inserts	型号 Type	订货号 Part Number
公 Male	UTL-HMK-004-MC	09140043041
母 Female	UTL-HMK-004-FC	09140043141

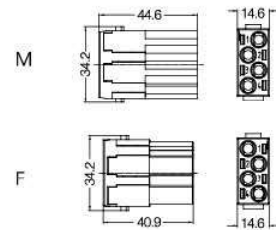

### 附件 Accessories

#### 40A 冷压针 Crimp contacts

接触电阻 Contact resistance  $\leq 0.3m\Omega$

镀银 Silver plated



公 Male	订货号 Part Number	母 Female	订货号 Part Number
CCSM-1.5	09320006104	CCSF-1.5	09320006204
CCSM-2.5	09320006105	CCSF-2.5	09320006205
CCSM-4.0	09320006107	CCSF-4.0	09320006207
CCSM-6.0	09320006108	CCSF-6.0	09320006208

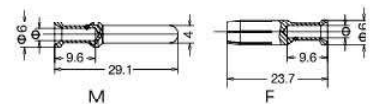

线规 Wire gauge	Φ	剥线长度 Stripping length
1.5 mm <sup>2</sup> AWG 16	1.75	9 mm
2.5mm <sup>2</sup> AWG 14	2.25	9 mm
4 mm <sup>2</sup> AWG 12	2.85	9.6 mm
6 mm <sup>2</sup> AWG 10	3.5	9.6 mm

### 工具 Tools

#### 冷压钳

Manual hydraulic



压接线径 Wire gauge	型号 Type	订货号 Part Number
1.5-6mm <sup>2</sup>	TL02-0G	09990000110

#### 退针器

Removal tool



适用类型 For	型号 Type	订货号 Part Number
40A 冷压针 Crimp contacts	TL06	09990000305

# Cage-clamp Module

## UTL-HME-005 弹片型模块 400V 16A

### 插芯 Inserts



可与框架及其他所有模块产品组合使用

Combination with hinged frame and other modules possible.

### 技术参数 Technical Characteristics

规范	Specifications	
规范	Specifications	DIN EN 60 664
		DIN EN 61 984
插芯	Inserts	
接插件针数	Number Of Contacts	5
依据 EN 61 984 的电气数据	Electrical Data Acc. To EN 61 984	
- 工作电流	- Rated Current	16A
- 工作电压	- Rated Voltage	400V
- 额定脉冲电压	- Rated Impulse Voltage	6kV
- 污染程度	- Pollution Degree	3
依据 UL 的额定电压	Rated Voltage Acc. to UL	600V
绝缘电阻	Insulation Resistance	$\geq 10^{10} \Omega$
材料	Material	聚碳酸酯 Polycarbonate
工作温度范围	Limiting Temperatures	-40°C...+125°C
依据 UL 94 的阻燃等级	Flammability Acc. to UL94	V0
可拔插次数	Mechanical Working Life-mating Cycles	$\geq 500$
插针	Contacts	
材料	Material	铜合金 Copper Alloy
表面处理	Surface	镀银 Hard-silver Plated
接触电阻	Contact Resistance	$\leq 3m\Omega$
弹片连接	Cage Clamp Terminal	
- mm <sup>2</sup>	- mm <sup>2</sup>	0.14-2.5mm <sup>2</sup>
- AWG	- AWG	26-14

### 电流负载能力 Current Carrying Capacity

电流负载能力所受的限制主要来自包含接插针的接插体可承受的最大温度  
测试和控制过程依据 DIN EN 60512-5  
The current carrying is limited by maximum temperature of materials for Inserts and contacts including terminals. Measuring and testing techniques according to DIN EN 60512-5

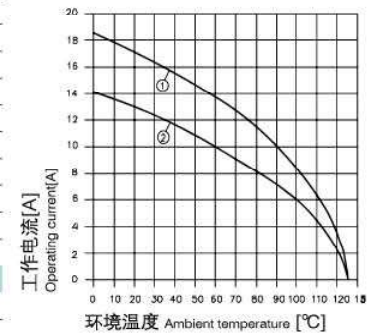

- ① 24 B外壳带6个模块，导线截面:2.5mm<sup>2</sup>
- ② 24 B外壳带6个模块，导线截面:1.5mm<sup>2</sup>
- ① 24 B hoods/housings with 6 modules, wire gauge:2.5mm<sup>2</sup>
- ② 24 B hoods/housings with 6 modules, wire gauge:1.5mm<sup>2</sup>

### 冷压连接 Crimp Terminal



插芯 Inserts	型号 Type	订货号 Part Number
公 Male	UTL-HME-005-MS	09140052616
母 Female	UTL-HME-005-FS	09140052716

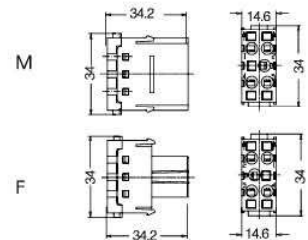

# Crimp Module

## UTL-HMK-006 冷压型模块 500V 16A

### 插芯 Inserts



可与框架及其他所有模块产品组合使用

Combination with hinged frame and other modules possible.

### 技术参数 Technical Characteristics

规范	Specifications	
规范	Specifications	DIN EN 60 664 DIN EN 61 984
插芯	Inserts	
接插件针数	Number Of Contacts	6
依据 EN 61 984 的电气数据	Electrical Data Acc. To EN 61 984	
- 工作电流	- Rated Current	16A
- 工作电压	- Rated Voltage	500V
- 额定脉冲电压	- Rated Impulse Voltage	6kV
- 污染程度	- Pollution Degree	3
依据 UL/CSA 的额定电压	Rated Voltage Acc. to UL/CSA	600V
绝缘电阻	Insulation Resistance	$\geq 10^{10} \Omega$
材料	Material	聚碳酸酯 Polycarbonate
工作温度范围	Limiting Temperatures	-40°C...+125°C
依据 UL 94 的阻燃等级	Flammability Acc. to UL94	V0
可拔插次数	Mechanical Working Life-mating Cycles	$\geq 500$
插针	Contacts	
材料	Material	铜合金 Copper Alloy
表面处理	Surface	镀银 Hard-silver Plated 镀金 Hard-gold Plated
接触电阻	Contact Resistance	$\leq 1m\Omega$
冷压连接	Cage Clamp Terminal	
- mm <sup>2</sup>	- mm <sup>2</sup>	0.14-4mm <sup>2</sup>
- AWG	- AWG	26-12

### 电流负载能力 Current Carrying Capacity

电流负载能力所受的限制主要来自包含接插针的接插体可承受的最大温度

测试和控制过程依据 DIN EN 60512-5  
The current carrying is limited by maximum temperature of materials for inserts and contacts including terminals.  
Measuring and testing techniques according to DIN EN 60512-5

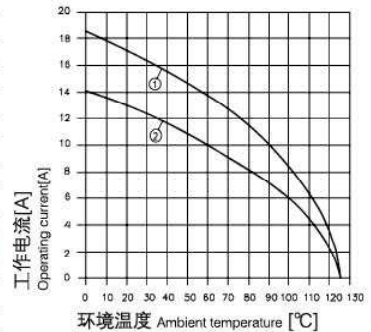

- ① 24 B外壳带6个模块, 导线截面: 2.5mm<sup>2</sup>
- ② 24 B外壳带6个模块, 导线截面: 1.5mm<sup>2</sup>
- ① 24 B hoods/housings with 6 modules, wire gauge: 2.5mm<sup>2</sup>
- ② 24 B hoods/housings with 6 modules, wire gauge: 1.5mm<sup>2</sup>

### 冷压连接 Crimp Terminal



插芯 Inserts	型号 Type	订货号 Part Number
公 Male	UTL-HME-006-MC	09140063001
母 Female	UTL-HME-006-FC	09140063101

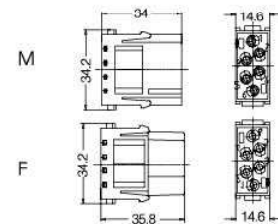

### 附件 Accessories

#### 16A 冷压针 Crimp contacts

接触电阻 Contact resistance  $\leq 1m\Omega$

镀银 Silver plated



镀金 Gold plated



#### 工具 Tools

冷压钳

Crimping tool



退针器

Removal tool



公 Male	订货号 Part Number	母 Female	订货号 Part Number
CESM-0.37	09330006127	CESF-0.37	09330006227
CESM-0.5	09330006121	CESF-0.5	09330006220
CESM-0.75	09330006114	CESF-0.75	09330006214
CESM-1.0	09330006105	CESF-1.0	09330006205
CESM-1.5	09330006104	CESF-1.5	09330006204
CESM-2.5	09330006102	CESF-2.5	09330006202
CESM-3.0	09330006106	CESF-3.0	09330006206
CESM-4.0	09330006107	CESF-4.0	09330006207
CEGM-0.37	09330006117	CEGF-0.37	09330006217
CEGM-0.5	09330006122	CEGF-0.5	09330006222
CEGM-0.75	09330006115	CEGF-0.75	09330006215
CEGM-1.0	09330006118	CEGF-1.0	09330006218
CEGM-1.5	09330006116	CEGF-1.5	09330006216
CEGM-2.5	09330006123	CEGF-2.5	09330006223
CEGM-4.0	09330006119	CEGF-4.0	09330006221

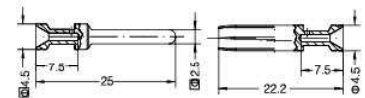

标示 Identification	线规 Wire gauge	剥线长度 Stripping length
no groove	0.14-0.37mm <sup>2</sup>	AWG 26-22
no groove	0.5mm <sup>2</sup>	AWG 20
1 groove	0.75mm <sup>2</sup>	AWG 18
1 groove	1.0mm <sup>2</sup>	AWG 18
2 groove	1.5mm <sup>2</sup>	AWG 16
3 groove	2.5mm <sup>2</sup>	AWG 14
wide groove	3mm <sup>2</sup>	AWG 12
no groove	4mm <sup>2</sup>	AWG 12

压接线径 Wire gauge	型号 Type	订货号 Part Number
0.5-4mm <sup>2</sup>	TL02G	09990000021
压接线径: 0.14-0.37mm <sup>2</sup> 请选择 TL02 冷压钳 Wire gauge: 0.14-0.37mm <sup>2</sup> please select TL02 Crimping tool		
适用类型 For	型号 Type	订货号 Part Number
16A 冷压针 Crimp contacts	TL01	09990000059

# Protected Module

## UTL-HVME-006 防护型模块 830V 16A

### 插芯 Inserts



可与框架及其他所有模块产品组合使用

Combination with hinged frame and other modules possible.

### 技术参数 Technical Characteristics

规范	Specifications	
规范	Specifications	DIN EN 60 664
		DIN EN 61 984
插芯	Inserts	
接插件针数	Number Of Contacts	6
依据 EN 61 984 的电气数据	Electrical Data Acc. To EN 61 984	
- 工作电流	- Rated Current	16A
- 工作电压	- Rated Voltage	830V
- 额定脉冲电压	- Rated Impulse Voltage	8kV
- 污染程度	- Pollution Degree	3
依据 UL/CSA 的额定电压	Rated Voltage Acc. to UL/CSA	600V
绝缘电阻	Insulation Resistance	$\geq 10^{10} \Omega$
材料	Material	聚碳酸酯 Polycarbonate
工作温度范围	Limiting Temperatures	-40°C...+125°C
依据 UL 94 的阻燃等级	Flammability Acc. to UL94	V0
可拔插次数	Mechanical Working Life-mating Cycles	$\geq 500$
插针	Contacts	
材料	Material	铜合金 Copper Alloy
表面处理	Surface	镀银 Hard-silver Plated 镀金 Hard-gold Plated
接触电阻	Contact Resistance	$\leq 1m\Omega$
冷压连接	Cage Clamp Terminal	
- mm <sup>2</sup>	- mm <sup>2</sup>	0.14-4mm <sup>2</sup>
- AWG	- AWG	26-12

### 电流负载能力 Current Carrying Capacity

电流负载能力所受的限制主要来自包含接插针的接插体可承受的最大温度

测试和控制过程依据 DIN EN 60512-5

The current carrying is limited by maximum temperature of materials for Inserts and contacts including terminals. Measuring and testing techniques according to DIN EN 60512-5

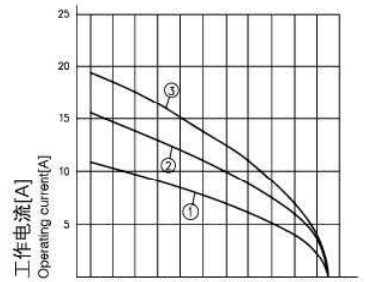

- ① 24 B外壳带6个模块, 导线截面:1.5mm<sup>2</sup>
- ② 24 B外壳带6个模块, 导线截面:2.5mm<sup>2</sup>
- ③ 24 B外壳带6个模块, 导线截面:4.0mm<sup>2</sup>
- ① 24 B hoods/housings with 6 modules, wire gauge:1.5mm<sup>2</sup>
- ② 24 B hoods/housings with 6 modules, wire gauge:2.5mm<sup>2</sup>
- ③ 24 B hoods/housings with 6 modules, wire gauge:4.0mm<sup>2</sup>

### 冷压连接 Crimp Terminal



插芯 Inserts	型号 Type	订货号 Part Number
公 Male	UTL-HVME-006-MC	09140063041
母 Female	UTL-HVME-006-FC	09140063141

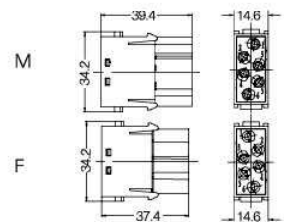

### 附件 Accessories

#### 16A 冷压针 Crimp contacts

接触电阻 Contact resistance  $\leq 1m\Omega$

镀银 Silver plated



镀金 Gold plate



#### 工具 Tools

冷压钳  
Crimping tool



退针器  
Removal tool



公 Male	订货号 Part Number	母 Female	订货号 Part Number
CESM-0.37	09330006127	CESF-0.37	09330006227
CESM-0.5	09330006121	CESF-0.5	09330006220
CESM-0.75	09330006114	CESF-0.75	09330006214
CESM-1.0	09330006105	CESF-1.0	09330006205
CESM-1.5	09330006104	CESF-1.5	09330006204
CESM-2.5	09330006102	CESF-2.5	09330006202
CESM-3.0	09330006106	CESF-3.0	09330006206
CESM-4.0	09330006107	CESF-4.0	09330006207
CEGM-0.37	09330006117	CEGF-0.37	09330006217
CEGM-0.5	09330006122	CEGF-0.5	09330006222
CEGM-0.75	09330006115	CEGF-0.75	09330006215
CEGM-1.0	09330006118	CEGF-1.0	09330006218
CEGM-1.5	09330006116	CEGF-1.5	09330006216
CEGM-2.5	09330006123	CEGF-2.5	09330006223
CEGM-4.0	09330006119	CEGF-4.0	09330006221

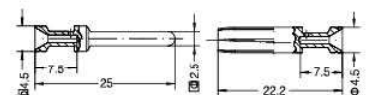

标示 Identification	线规 Wire gauge	剥线长度 Stripping length
no groove	0.14-0.37mm <sup>2</sup>	7.5mm
no groove	0.5mm <sup>2</sup>	7.5mm
1 groove	0.75mm <sup>2</sup>	7.5mm
1 groove	1mm <sup>2</sup>	7.5mm
2 groove	1.5mm <sup>2</sup>	7.5mm
3 groove	2.5mm <sup>2</sup>	7.5mm
wide groove	3mm <sup>2</sup>	7.5mm
no groove	4mm <sup>2</sup>	7.5mm

### 压接线经 Wire gauge 型号 Type 订货号 Part Number

0.5-4mm<sup>2</sup> TL02G 09990000021

压接线径: 0.14-0.37mm<sup>2</sup>请选择TL02冷压钳  
Wire gauge: 0.14-0.37mm<sup>2</sup> please select TL02 Crimping tool

### 适用类型 For 型号 Type 订货号 Part Number

16A 冷压针 Crimp contacts TL01 09990000059

# Crimp Module

## UTL-HMEE-008 冷压型模块 400V 16A

### 插芯 Inserts



可与框架及其他所有模块产品组合使用  
Combination with hinged frame and other modules possible.

### 技术参数 Technical Characteristics

规范	Specifications	
规范	Specifications	DIN EN 60 664
		DIN EN 61 984
插芯	Inserts	
接插件针数	Number Of Contacts	8
依据 EN 61 984 的电气数据	Electrical Data Acc. To EN 61 984	
-工作电流	-Rated Current	16A
-工作电压	-Rated Voltage	400V
-额定脉冲电压	-Rated Impulse Voltage	6kV
-污染程度	-Pollution Degree	3
依据UL/CSA的额定电压	Rated Voltage Acc. to UL/CSA	600V
绝缘电阻	Insulation Resistance	$\geq 10^{10} \Omega$
材料	Material	聚碳酸酯 Polycarbonate
工作温度范围	Limiting Temperatures	-40°C...+125°C
依据UL 94的阻燃等级	Flammability Acc. to UL94	V0
可拔插次数	Mechanical Working Life-mating Cycles	$\geq 500$
插针	Contacts	
材料	Material	铜合金 Copper Alloy
表面处理	Surface	镀银 Hard-silver Plated 镀金 Hard-gold Plated
接触电阻	Contact Resistance	$\leq 1m\Omega$
冷压连接	Cage Clamp Terminal	
- mm <sup>2</sup>	- mm <sup>2</sup>	0.14-4mm <sup>2</sup>
-AWG	-AWG	26-12

**电流负载能力 Current Carrying Capacity**  
电流负载能力所受的限制主要来自包含插针的接插体可承受的最大温度  
测试和控制过程依据 DIN EN 60512-5  
The current carrying is limited by maximum temperature of materials for inserts and contacts including terminals.  
Measuring and testing techniques according to DIN EN 60512-5

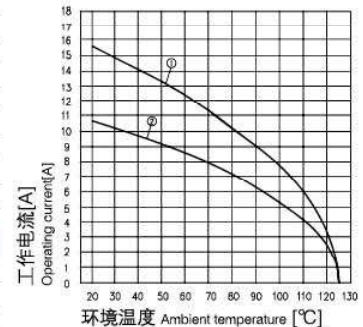

- ① 24 B外壳带6个模块, 导线截面:2.5mm<sup>2</sup>
- ② 24 B外壳带6个模块, 导线截面:1.5mm<sup>2</sup>
- ① 24 B hoods/housings with 6 modules, wire gauge:2.5mm<sup>2</sup>
- ② 24 B hoods/housings with 6 modules, wire gauge:1.5mm<sup>2</sup>

### 冷压连接 Crimp Terminal



插芯 Inserts	型号 Type	订货号 Part Number
公 Male	UTL-HMEE-008-MC	09140083001
母 Female	UTL-HMEE-008-FC	09140083101

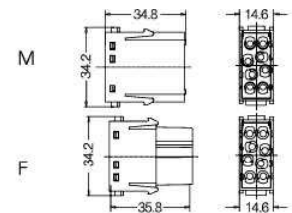

### 附件 Accessories

#### 16A 冷压针 Crimp contacts

接触电阻 Contact resistance  $\leq 1m\Omega$

镀银 Silver plated



镀金 Gold plated



#### 工具 Tools

冷压钳  
Crimping tool



退针器  
Removal tool



公 Male	订货号 Part Number	母 Female	订货号 Part Number
CESM-0.37	09330006127	CESF-0.37	09330006227
CESM-0.5	09330006121	CESF-0.5	09330006220
CESM-0.75	09330006114	CESF-0.75	09330006214
CESM-1.0	09330006105	CESF-1.0	09330006205
CESM-1.5	09330006104	CESF-1.5	09330006204
CESM-2.5	09330006102	CESF-2.5	09330006202
CESM-3.0	09330006106	CESF-3.0	09330006206
CESM-4.0	09330006107	CESF-4.0	09330006207

公 Male	订货号 Part Number	母 Female	订货号 Part Number
CEGM-0.37	09330006117	CEGF-0.37	09330006217
CEGM-0.5	09330006122	CEGF-0.5	09330006222
CEGM-0.75	09330006115	CEGF-0.75	09330006215
CEGM-1.0	09330006118	CEGF-1.0	09330006218
CEGM-1.5	09330006116	CEGF-1.5	09330006216
CEGM-2.5	09330006123	CEGF-2.5	09330006223
CEGM-4.0	09330006119	CEGF-4.0	09330006221

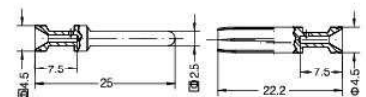

标示 Identification	线规 Wire gauge	剥线长度 Stripping length	
no groove	0.14-0.37mm <sup>2</sup>	AWG 26-22	7.5mm
no groove	0.5mm <sup>2</sup>	AWG 20	7.5mm
1 groove	0.75mm <sup>2</sup>	AWG 18	7.5mm
1 groove	1.0mm <sup>2</sup>	AWG 18	7.5mm
2 groove	1.5mm <sup>2</sup>	AWG 16	7.5mm
3 groove	2.5mm <sup>2</sup>	AWG 14	7.5mm
wide groove	3mm <sup>2</sup>	AWG 12	7.5mm
no groove	4mm <sup>2</sup>	AWG 12	7.5mm

压接线径 Wire gauge	型号 Type	订货号 Part Number
0.5-4mm <sup>2</sup>	TL02G	09990000021

压接线径: 0.14-0.37mm<sup>2</sup>请选择TL02冷压钳  
Wire gauge: 0.14-0.37mm<sup>2</sup> please select TL02 Crimping tool

适用类型 For	型号 Type	订货号 Part Number
16A 冷压针 Crimp contacts	TL01	09990000059



# Crimp Module

## UTL-H2MEE-020 冷压型模块 500V 16A

### 插芯 Inserts



可与框架及其他所有模块产品组合使用

Combination with hinged frame and other modules possible.

### 技术参数 Technical Characteristics

规范	Specifications	
规范	Specifications	DIN EN 60 664
		DIN EN 61 984
插芯	Inserts	
接插件针数	Number Of Contacts	20
依据 EN 61 984 的电气数据	Electrical Data Acc. To EN 61 984	
-工作电流	-Rated Current	16A
-工作电压	-Rated Voltage	500V
-额定脉冲电压	-Rated Impulse Voltage	6kV
-污染程度	-Pollution Degree	3
依据 UL/CSA 的额定电压	Rated Voltage Acc. to UL/CSA	600V
绝缘电阻	Insulation Resistance	$\geq 10^{10} \Omega$
材料	Material	聚碳酸酯 Polycarbonate
工作温度范围	Limiting Temperatures	-40°C...+125°C
依据 UL 94 的阻燃等级	Flammability Acc. to UL94	V0
可拔插次数	Mechanical Working Life-mating Cycles	$\geq 500$
插针	Contacts	
材料	Material	铜合金 Copper Alloy
表面处理	Surface	镀银 Hard-silver Plated 镀金 Hard-gold Plated
接触电阻	Contact Resistance	$\leq 1m\Omega$
冷压连接	Cage Clamp Terminal	
- mm <sup>2</sup>	- mm <sup>2</sup>	0.14-4mm <sup>2</sup>
-AWG	-AWG	26-12

### 电流负载能力 Current Carrying Capacity

电流负载能力所受的限制主要来自包含接插针的接插体可承受的最大温度  
测试和控制过程依据 DIN EN 60512-5  
The current carrying is limited by maximum temperature of materials for inserts and contacts including terminals.  
Measuring and testing techniques according to DIN EN 60512-5

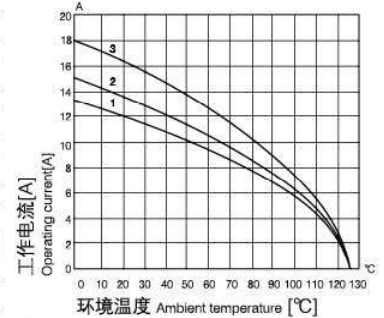

- ① 24 B 外壳带3个模块, 导线截面:1.5mm<sup>2</sup>
- ② 24 B 外壳带3个模块, 导线截面:2.5mm<sup>2</sup>
- ③ 24 B 外壳带3个模块, 导线截面:4.0mm<sup>2</sup>
- ① 24 B hoods/housings with 3 modules, wire gauge:1.5mm<sup>2</sup>
- ② 24 B hoods/housings with 3 modules, wire gauge:2.5mm<sup>2</sup>
- ③ 24 B hoods/housings with 3 modules, wire gauge:4.0mm<sup>2</sup>

### 冷压连接 Crimp Terminal



插芯 Inserts	型号 Type	订货号 Part Number
公 Male	UTL-H2MEE-020-MC	09140203001
母 Female	UTL-H2MEE-020-FC	09140203101

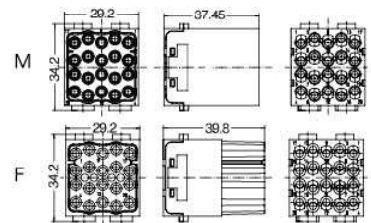

### 附件 Accessories

#### 16A 冷压针 Crimp contacts

接触电阻 Contact resistance  $\leq 1m\Omega$

镀银 Silver plated



镀金 Gold plated



#### 工具 Tools

冷压钳  
Crimping tool



退针器  
Removal tool



公 Male	订货号 Part Number	母 Female	订货号 Part Number
CESM-0.37	09330006127	CESF-0.37	09330006227
CESM-0.5	09330006121	CESF-0.5	09330006220
CESM-0.75	09330006114	CESF-0.75	09330006214
CESM-1.0	09330006105	CESF-1.0	09330006205
CESM-1.5	09330006104	CESF-1.5	09330006204
CESM-2.5	09330006102	CESF-2.5	09330006202
CESM-3.0	09330006106	CESF-3.0	09330006206
CESM-4.0	09330006107	CESF-4.0	09330006207

公 Male	订货号 Part Number	母 Female	订货号 Part Number
CEGM-0.37	09330006117	CEGF-0.37	09330006217
CEGM-0.5	09330006122	CEGF-0.5	09330006222
CEGM-0.75	09330006115	CEGF-0.75	09330006215
CEGM-1.0	09330006118	CEGF-1.0	09330006218
CEGM-1.5	09330006116	CEGF-1.5	09330006216
CEGM-2.5	09330006123	CEGF-2.5	09330006223
CEGM-4.0	09330006119	CEGF-4.0	09330006221

压接线径 Wire gauge	型号 Type	订货号 Part Number
0.5-4mm <sup>2</sup>	TL02G	09990000021

压接线径: 0.14-0.37mm<sup>2</sup>请选择 TL02 冷压钳  
Wire gauge: 0.14-0.37mm<sup>2</sup> please select TL02 Crimping tool

适用类型 For	型号 Type	订货号 Part Number
16A 冷压针 Crimp contacts	TL01	09990000059

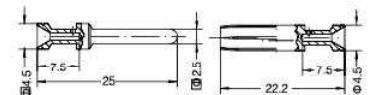

标示 Identification	线规 Wire gauge	剥线长度 Stripping length	
no groove	0.14-0.37mm <sup>2</sup>	AWG 26-22	7.5mm
no groove	0.5mm <sup>2</sup>	AWG 20	7.5mm
1 groove	0.75mm <sup>2</sup>	AWG 18	7.5mm
1 groove	1.0mm <sup>2</sup>	AWG 18	7.5mm
2 groove	1.5mm <sup>2</sup>	AWG 16	7.5mm
3 groove	2.5mm <sup>2</sup>	AWG 14	7.5mm
wide groove	3mm <sup>2</sup>	AWG 12	7.5mm
no groove	4mm <sup>2</sup>	AWG 12	7.5mm

# Crimp Module

## UTL-HMD-012 冷压型模块 250V 10A

### 插芯 Inserts

 可与框架及其他所有模块产品组合使用  
Combination with hinged frame and other modules possible.

### 技术参数 Technical Characteristics

规范	Specifications	
规范	Specifications	DIN EN 60 664
		DIN EN 61 984
插芯	Inserts	
接插件针数	Number Of Contacts	12
依据 EN 61 984 的电气数据	Electrical Data Acc. To EN 61 984	
-工作电流	-Rated Current	10A
-工作电压	-Rated Voltage	250V
-额定脉冲电压	-Rated Impulse Voltage	4kV
-污染程度	-Pollution Degree	3
依据UL/CSA的额定电压	Rated Voltage Acc. to UL/CSA	600V
绝缘电阻	Insulation Resistance	$\geq 10^{10} \Omega$
材料	Material	聚碳酸酯 Polycarbonate
工作温度范围	Limiting Temperatures	-40°C...+125°C
依据UL 94的阻燃等级	Flammability Acc. to UL94	V0
可拔插次数	Mechanical Working Life-mating Cycles	$\geq 500$
插针	Contacts	
材料	Material	铜合金 Copper Alloy
表面处理	Surface	镀银 Hard-silver Plated 镀金 Hard-gold Plated
接触电阻	Contact Resistance	$\leq 3m\Omega$
冷压连接	Cage Clamp Terminal	
- mm <sup>2</sup>	- mm <sup>2</sup>	0.14-2.5mm <sup>2</sup>
-AWG	-AWG	26-14

### 电流负载能力 Current Carrying Capacity

电流负载能力所受的限制主要来自包含接插针的接插体可承受的最大温度  
测试和控制过程依据 DIN EN 60512-5  
The current carrying is limited by maximum temperature of materials for inserts and contacts including terminals.  
Measuring and testing techniques according to DIN EN 60512-5

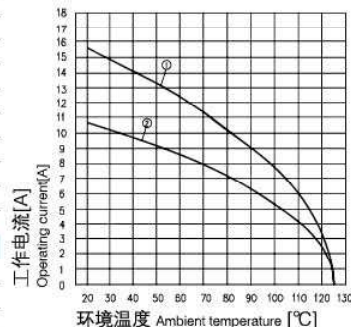

- ① 24 B外壳带6个模块, 导线截面:2.5mm<sup>2</sup>
- ② 24 B外壳带6个模块, 导线截面:1.5mm<sup>2</sup>
- ① 24 B hoods/housings with 6 modules, wire gauge:2.5mm<sup>2</sup>
- ② 24 B hoods/housings with 6 modules, wire gauge:1.5mm<sup>2</sup>

### 冷压连接 Crimp Terminal



插芯 Inserts	型号 Type	订货号 Part Number
公 Male	UTL-HMD-012-MC	09140123001
母 Female	UTL-HMD-012-FC	09140123101

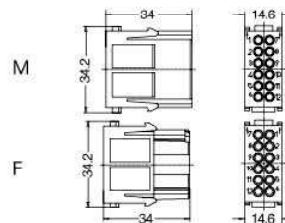

### 附件 Accessories

#### 10A 冷压针 Crimp contacts

接触电阻 Contact resistance  $\leq 3m\Omega$

镀银 Silver plated



镀金 Gold plated



#### 工具 Tools

冷压钳  
Crimping tool



退针器  
Removal tool



公 Male	订货号 Part Number	母 Female	订货号 Part Number
CDSM-0.37	09150006104	CDSF-0.37	09150006204
CDSM-0.5	09150006103	CDSF-0.5	09150006203
CDSM-0.75	09150006105	CDSF-0.75	09150006205
CDSM-1.0	09150006102	CDSF-1.0	09150006202
CDSM-1.5	09150006101	CDSF-1.5	09150006201
CDSM-2.5	09150006106	CDSF-2.5	09150006206
CDGM-0.37	09150006124	CDGF-0.37	09150006224
CDGM-0.5	09150006123	CDGF-0.5	09150006223
CDGM-0.75	09150006125	CDGF-0.75	09150006225
CDGM-1.0	09150006122	CDGF-1.0	09150006222
CDGM-1.5	09150006121	CDGF-1.5	09150006221
CDGM-2.5	09150006126	CDGF-2.5	09150006226

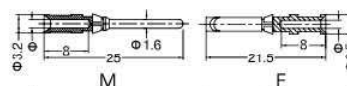

线规 Wire gauge	Φ	剥线长度 Stripping length
0.14-0.37 mm <sup>2</sup>	AWG 26-22	0.9
0.5 mm <sup>2</sup>	AWG 20	1.1
0.75 mm <sup>2</sup>	AWG 18	1.3
1 mm <sup>2</sup>	AWG 18	1.45
1.5 mm <sup>2</sup>	AWG 16	1.75
2.5 mm <sup>2</sup>	AWG 14	2.25

压接线径 Wire gauge	型号 Type	订货号 Part Number
0.14-4mm <sup>2</sup>	TL02G	09990000021

适用类型 For	型号 Type	订货号 Part Number
10A 冷压针 Crimp contacts	TL00	09990000059

# Crimp Module

## UTL-HMDD-017 冷压型模块 160V 10A

### 插芯 Inserts



可与框架及其他所有模块产品组合使用  
Combination with hinged frame and other modules possible.

### 技术参数 Technical Characteristics

规范	Specifications	
规范	Specifications	DIN EN 60 664
		DIN EN 61 984
插芯	Inserts	
接插件针数	Number Of Contacts	17
依据 EN 61 984 的电气数据	Electrical Data Acc. To EN 61 984	
-工作电流	-Rated Current	10A
-工作电压	-Rated Voltage	160V
-额定脉冲电压	-Rated Impulse Voltage	2.5kV
-污染程度	-Pollution Degree	3
依据 UL/CSA 的额定电压	Rated Voltage Acc. to UL/CSA	250V
绝缘电阻	Insulation Resistance	$\geq 10^{10} \Omega$
材料	Material	聚碳酸酯 Polycarbonate
工作温度范围	Limiting Temperatures	-40°C...+125°C
依据 UL 94 的阻燃等级	Flammability Acc. to UL94	V0
可拔插次数	Mechanical Working Life-mating Cycles	$\geq 500$
材料	Material	铜合金 Copper Alloy
表面处理	Surface	镀银 Hard-silver Plated
		镀金 Hard-gold Plated
接触电阻	Contact Resistance	$\leq 3m\Omega$
冷压连接	Cage Clamp Terminal	
- mm <sup>2</sup>	- mm <sup>2</sup>	0.14-2.5mm <sup>2</sup>
-AWG	-AWG	26-14

### 电流负载能力 Current Carrying Capacity

电流负载能力所受的限制主要来自包含接插针的接插体可承受的最大温度  
测试和控制过程依据 DIN EN 60512-5  
The current carrying is limited by maximum temperature of materials for inserts and contacts including terminals.  
Measuring and testing techniques according to DIN EN 60512-5

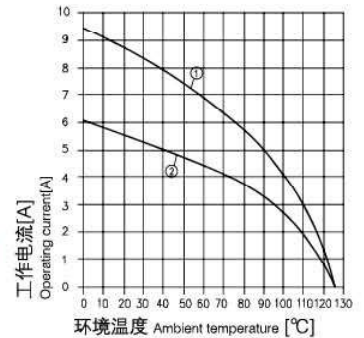

- ① 24 B外壳带6个模块，导线截面:1.5mm<sup>2</sup>
- ② 24 B外壳带6个模块，导线截面:1.0mm<sup>2</sup>
- ① 24 B hoods/housings with 6 modules, wire gauge:1.5mm<sup>2</sup>
- ② 24 B hoods/housings with 6 modules, wire gauge:1.0mm<sup>2</sup>

### 冷压连接 Crimp Terminal



插芯 Inserts	型号 Type	订货号 Part Number
公 Male	UTL-HMDD-017-MC	09140173001
母 Female	UTL-HMDD-017-FC	09140173101

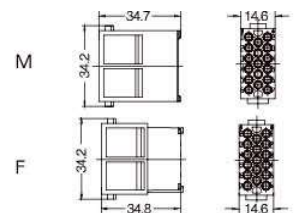

### 附件 Accessories

10A 冷压针 Crimp contacts

接触电阻 Contact resistance  $\leq 3m\Omega$   
镀银 Silver plated



镀金 Gold plated



工具 Tools

冷压钳  
Crimping tool



退针器  
Removal tool



公 Male	订货号 Part Number	母 Female	订货号 Part Number
CDSM-0.37	09150006104	CDSF-0.37	09150006204
CDSM-0.5	09150006103	CDSF-0.5	09150006203
CDSM-0.75	09150006105	CDSF-0.75	09150006205
CDSM-1.0	09150006102	CDSF-1.0	09150006202
CDSM-1.5	09150006101	CDSF-1.5	09150006201
CDSM-2.5	09150006106	CDSF-2.5	09150006206
CDGM-0.37	09150006124	CDGF-0.37	09150006224
CDGM-0.5	09150006123	CDGF-0.5	09150006223
CDGM-0.75	09150006125	CDGF-0.75	09150006225
CDGM-1.0	09150006122	CDGF-1.0	09150006222
CDGM-1.5	09150006121	CDGF-1.5	09150006221
CDGM-2.5	09150006126	CDGF-2.5	09150006226

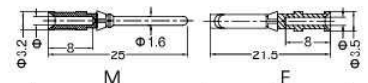

线规 Wire gauge	Φ	剥线长度 Stripping length
0.14-0.37 mm <sup>2</sup>	AWG 26-22	0.9 8 mm
0.5 mm <sup>2</sup>	AWG 20	1.1 8 mm
0.75 mm <sup>2</sup>	AWG 18	1.3 8 mm
1 mm <sup>2</sup>	AWG 18	1.45 8 mm
1.5 mm <sup>2</sup>	AWG 16	1.75 8 mm
2.5 mm <sup>2</sup>	AWG 14	2.25 6 mm

压接线经 Wire gauge	型号 Type	订货号 Part Number
0.14-4mm <sup>2</sup>	TL02G	09990000021

适用类型 For	型号 Type	订货号 Part Number
10A 冷压针 Crimp contacts	TL00	09990000059

# D-Sub Module

## UTL-HMDS-009 D-Sub 模块 50V 5A

### 插芯 Inserts



可与框架及其他所有模块产品组合使用  
Combination with hinged frame and other modules possible.

### 技术参数 Technical Characteristics

规范	Specifications	
规范	Specifications	DIN EN 60 664 DIN EN 61 984
插芯	Inserts	
接插件针数	Number Of Contacts	9
依据 EN 61 984 的电气数据	Electrical Data Acc. To EN 61 984	
-工作电流	-Rated Current	5A
-工作电压	-Rated Voltage	50V
-额定脉冲电压	-Rated Impulse Voltage	0.8kV
-污染程度	-Pollution Degree	3
绝缘电阻	Insulation Resistance	$\geq 10^{10} \Omega$
材料	Material	聚碳酸酯 Polycarbonate
工作温度范围	Limiting Temperatures	-40°C...+125°C
依据 UL 94 的阻燃等级	Flammability Acc. to UL94	V0
可拔插次数	Mechanical Working Life-mating Cycles	$\geq 500$
插针	Contacts	
材料	Material	铜合金 Copper Alloy
表面处理	Surface	镀银 Hard-silver Plated 镀金 Hard-gold Plated
接触电阻	Contact Resistance	$\leq 3m \Omega$
冷压连接	Cage Clamp Terminal	
- mm <sup>2</sup>	- mm <sup>2</sup>	0.09-0.82mm <sup>2</sup>
-AWG	-AWG	28-18

### 冷压连接 Crimp Terminal



插芯 Inserts	型号 Type	订货号 Part Number
公 Male	UTL-HMDS-009-MC	09140093001
母 Female	UTL-HMDS-009-FC	09140093101

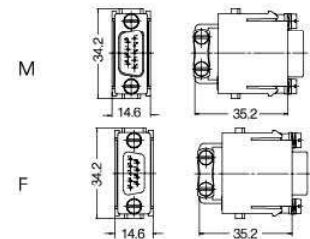

### 附件 Accessories

#### 5A 冷压针 Crimp contacts

接触电阻 Contact resistance  $\leq 3m \Omega$

镀银 Silver plated



镀金 Gold plated



公 Male	订货号 Part Number	母 Female	订货号 Part Number
CSSM-0.25	61030000010	CSSF-0.25	61030000012
CSSM-0.33	61030000018	CSSF-0.33	61030000020
CSSM-0.52	61030000028	CSSF-0.52	61030000030
CSSM-0.82	61030000040	CSSF-0.82	61030000042
CSGM-0.25	61030000078	CSGF-0.25	61030000080
CSGM-0.33	61030000094	CSGF-0.33	61030000096
CSGM-0.52	61030000073	CSGF-0.52	61030000074
CSGM-0.82	61030000082	CSGF-0.82	61030000084

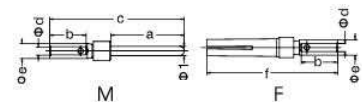

a	b	c	d	e	f
8.23	4.2	14.0	1.35	1.75	13.6
0.10	4.0	14.0	1.12	1.66	14.4
8.10	4.0	14.8	0.90	1.66	14.4
8.10	4.0	14.8	0.64	1.66	14.4

线规 Wire gauge	剥线长度 Stripping length	
0.09-0.21 mm <sup>2</sup>	AWG 28-24	5 mm
0.13-0.33 mm <sup>2</sup>	AWG 26-22	5 mm
0.33-0.52 mm <sup>2</sup>	AWG 22-20	5 mm
0.33-0.82 mm <sup>2</sup>	AWG 22-18	5 mm

#### 工具 Tools

##### 冷压钳

Crimping tool



压接线经 Wire gauge	型号 Type	订货号 Part Number
0.09-0.82mm <sup>2</sup>	TL03	09990000001

##### 退针器

Removal tool



适用类型 For	型号 Type	订货号 Part Number
5A 冷压针 Crimp contacts	TL08	09990000368

# High density module

## UTL-HMDS-025 高密度模块 50V 4A

### 插芯 Inserts



可与框架及其他所有模块产品组合使用

Combination with hinged frame and other modules possible.

### 技术参数 Technical Characteristics

规范	Specifications	
规范	Specifications	DIN EN 60 664
		DIN EN 61 984
插芯	Inserts	
接插件针数	Number Of Contacts	25
依据 EN 61 984 的电气数据	Electrical Data Acc. To EN 61 984	
- 工作电流	- Rated Current	4A
- 工作电压	- Rated Voltage	50V
- 额定脉冲电压	- Rated Impulse Voltage	0.8kV
- 污染程度	- Pollution Degree	3
绝缘电阻	Insulation Resistance	$\geq 10^{10} \Omega$
材料	Material	聚碳酸酯 Polycarbonate
工作温度范围	Limiting Temperatures	-40°C...+125°C
依据 UL 94 的阻燃等级	Flammability Acc. to UL94	V0
可拔插次数	Mechanical Working Life-mating Cycles	$\geq 500$
插针	Contacts	
材料	Material	铜合金 Copper Alloy
表面处理	Surface	镀银 Hard-silver Plated 镀金 Hard-gold Plated
接触电阻	Contact Resistance	$\leq 3m\Omega$
冷压连接	Cage Clamp Terminal	
- mm <sup>2</sup>	- mm <sup>2</sup>	0.09-0.52mm <sup>2</sup>
- AWG	- AWG	28-20

### 电流负载能力 Current Carrying Capacity

电流负载能力所受的限制主要来自包含接插针的接插体可承受的最大温度  
测试和控制过程依据 DIN EN 60512-5  
The current carrying is limited by maximum temperature of materials for inserts and contacts including terminals.  
Measuring and testing techniques according to DIN EN 60512-5

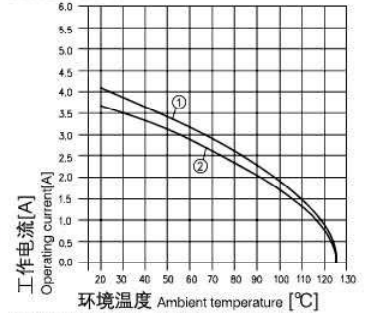

- ① 24B外壳带6个模块，导线截面0.5mm<sup>2</sup>（车制针）
- ② 24B外壳带6个模块，导线截面0.5mm<sup>2</sup>（冲压针）
- ① 24 B hoods/housings with 6 modules, wire gauge:1.5mm<sup>2</sup> (turned contacts)
- ② 24 B hoods/housings with 6 modules, wire gauge:1.0mm<sup>2</sup> (stamped contacts)

### 冷压连接 Crimp Terminal



插芯 Inserts	型号 Type	订货号 Part Number
公 Male	UTL-HMDS-025-MC	09140253001
母 Female	UTL-HMDS-025-FC	09140253101

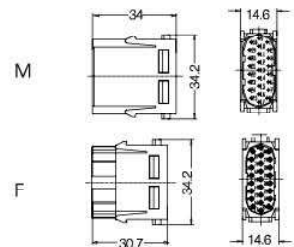

### 附件 Accessories

105

接触电阻 Contact resistance  $\leq 3m\Omega$   
镀银 Silver plated



镀金 Gold plated



公 Male	订货号 Part Number	母 Female	订货号 Part Number
CSSM-0.25	61030000010	CSSF-0.25	61030000012
CSSM-0.33	61030000018	CSSF-0.33	61030000020
CSSM-0.52	61030000028	CSSF-0.52	61030000030
CSSM-0.82	61030000040	CSSF-0.82	61030000042
CSGM-0.25	61030000078	CSGF-0.25	61030000080
CSGM-0.33	61030000094	CSGF-0.33	61030000096
CSGM-0.52	61030000073	CSGF-0.52	61030000074
CSGM-0.82	61030000082	CSGF-0.82	61030000084

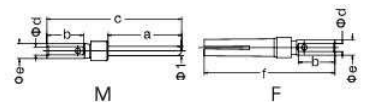

a	b	c	d	e	f
8.23	4.2	14.0	1.36	1.75	13.6
0.10	4.0	14.0	1.12	1.68	14.4
8.10	4.0	14.8	0.90	1.68	14.4
8.10	4.0	14.8	0.64	1.68	14.4

线规 Wire gauge	剥线长度 Stripping length
0.09-0.21 mm <sup>2</sup>	AWG 28-24 5 mm
0.13-0.33 mm <sup>2</sup>	AWG 26-22 5 mm
0.33-0.52 mm <sup>2</sup>	AWG 22-20 5 mm
0.33-0.82 mm <sup>2</sup>	AWG 22-18 5 mm

### 工具 Tools

冷压钳 Crimping tool



压接线经 Wire gauge	型号 Type	订货号 Part Number
0.09-0.82mm <sup>2</sup>	TL03	0999000001

退针器 Removal tool



适用类型 For	型号 Type	订货号 Part Number
5A 冷压针 Crimp contacts	TL08	09990000368

# Module

## UTL-HM-RJ45 模块 50V 5A

### 插芯 Inserts



可与框架及其他所有模块产品组合使用  
Combination with hinged frame and other modules possible.

### 技术参数 Technical Characteristics

规范	Specifications	
规范	Specifications	DIN EN 60 664
		DIN EN 61 984
插芯	Inserts	
接插件针数	Number of contacts	8
依据 EN 61 984 的电气数据	Electrical data acc. to EN 61 984	
-额定电流	-Rated current	1A
-额定电压	-Rated voltage	50V
-额定脉冲电压	-Rated impulse voltage	0.8kV
-污染程度	-Pollution degree	3
依据UL的额定电压	Rated voltage acc. to UL	< 30 V
传输特性	Transmission features	Category 6 /Class E up to 500 MHz; acc. to ISO/IEC 11 801:2002 and EN 50 173-1
传输速率	Transmission rate	10/100/1000 Mbit/s
绝缘电阻	Insulation resistance	$\geq 10^{10} \Omega$
材料	Material	聚碳酸酯 polycarbonate
工作温度范围	Limiting temperatures	-40°C...+85°C
依据UL 94 的阻燃等级	Flammability acc. to UL 94	V0
可拔插次数	Mechanical working life	
	- mating cycle	$\geq 500$

插芯 用于接缆线 Inserts for patch cable



插芯 Inserts	型号 Type	订货号 Part Number
公 Male	UTL-HM-RJ45-M	09140014623
母 Female	UTL-HM-RJ45-F	09140014721

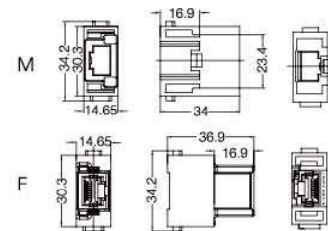

### 适配器 Adapter



描述 Inserts	型号 Type	订货号 Part Number
与公插芯搭配 go with male insert	UTL-HM-RJ45-APT	09140009966
仅用于标准电缆接线 for standard cable		

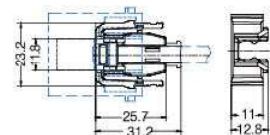

# Pneumatic Module

## UTL-HMP-002 气动模块

### 插芯 Inserts



可与框架及其他所有模块产品组合使用  
Combination with hinged frame and other modules possible.

### 技术参数 Technical Characteristics

规范	Specifications	
规范	Specifications	DIN EN 60 664 DIN EN 61 984
插芯	Inserts	
接插件针数	Number Of Contacts	2
材料	Material	聚碳酸酯 Polycarbonate
工作温度范围	Limiting Temperatures	-40°C...+80°C
依据UL 94的阻燃等级	Flammability Acc. To UI94	V0
可拔插次数	Mechanical Working Life-mating Cycles	≥500
插针	Contacts	
材料	Material	聚甲醛 Delrin Acetal
颜色	Colour	黑色black
软管连接	Tube Termination-	
-内径	Internal Diameter (id)	6.0mm/1/4"
工作压力	Working Pressure	最大(Up To) 8 Bar/116 Psi
密封圈	Sealing	
-材料	-Material	丁晴橡胶 Buna-n
闭锁阀	Shut Off Valve	
-材料	-Material	聚丙烯 Polypropylen

### 气动模块 Pneumatic Module



描述 Description	型号 Type	订货号 Part Number
	UTL-HMP-002	09140024501

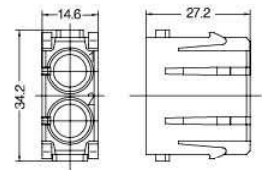

### 附件 Accessories

针 用于软管内径(ID) For Tubeinternal Diameter(ID)



描述 Description	类别 Category	ID	型号 Type	订货号 Part Number
无锁止 Without Shut Off	公 Male	6.0mm	PCM-6.0	09140006174
无锁止 Without Shut Off	母 Female	6.0mm	PCF-6.0	09140006274

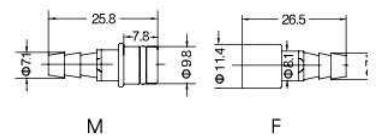

针 用于软管内径(ID) For Tubeinternal Diameter(ID)



描述 Description	类别 Category	ID	型号 Type	订货号 Part Number
带锁止 With Shut Off	母 Female	6.0mm	PCFS-6.0	09140006279

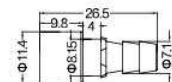

# Pneumatic Module

## UTL-HMP-003 气动模块

### 插芯 Inserts



可与框架及其他所有模块产品组合使用  
Combination with hinged frame and other modules possible.

### 技术参数 Technical Characteristics

规范	Specifications	
规范	Specifications	DIN EN 60 664
		DIN EN 61 984
插芯	Inserts	
接插件针数	Number Of Contacts	3
材料	Material	聚碳酸酯 Polycarbonate
工作温度范围	Limiting Temperatures	-40°C...+80°C
依据UL 94的阻燃等级	Flammability Acc. To UI94	V0
可拔插次数	Mechanical Working Life-mating Cycles	≥ 500
插针	Contacts	
材料	Material	聚甲醛 Delrin Acetal
颜色	Colour	黑色 black
软管连接	Tube Termination	
-内径	- Internal Diameter (id)	1.6mm/1/16 "
		3mm
		4mm/1/8 "
工作压力	Working Pressure	最大( Up To) 8 Bar/116 Psi
密封圈	Sealing	
-材料	-Material	丁晴橡胶 Buna-n
闭锁阀	Shut Off Valve	
-材料	-Material	聚丙烯 Polypropylen

### 气动模块 Pneumatic Module



描述 Description	型号 Type	订货号 Part Number
	UTL-HMP-003	09140034501

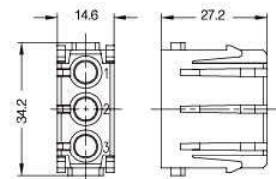

### 附件 Accessories

针 用于软管内径(ID) For Tube internal Diameter(ID)



描述 Description	类别 Category	ID	型号 Type	订货号 Part Number
无锁止 Without Shut Off	公 Male	1.6mm	PCM-1.6	09140006151
		3.0mm	PCM-3.0	09140006251
		4.0mm	PCM-4.0	09140006152
无锁止 Without Shut Off	母 Female	1.6mm	PCF-1.6	09140006252
		3.0mm	PCF-3.0	09140006153
		4.0mm	PCF-4.0	09140006253

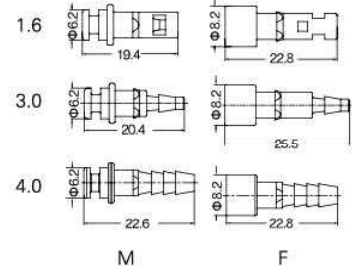

针 用于软管内径(ID) For Tube internal Diameter(ID)



描述 Description	类别 Category	ID	型号 Type	订货号 Part Number
带锁止 With Shut Off	母 Female	1.6mm	PCFS-1.6	09140006256
		3.0mm	PCFS-3.0	09140006257
		4.0mm	PCFS-4.0	09140006258

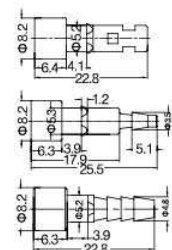



# UTL-HQ 系列 / HQ SERIES

紧凑小体积型插芯 / Compact Series



# Compact Series

## UTL-HQ-002/0 紧凑型插芯

### 技术参数 Technical Characteristics

规范	Specifications	
规范	Specifications	DIN EN 60 664
		DIN EN 61 984
插芯	Inserts	
依据 EN 61 984的额定电压	Electrical Data Acc. To EN 61 984	
接插件针数	Number Of Contacts	2+PE
额定电流	Rated Current	40A
额定电压	Rated Voltage	400V
额定脉冲电压	Rated Impulse Voltage	6kV
污染程度	Pollution Degree	3
依据UL/CSA额定电压	Rated Voltage Acc.to UI CSA	400V
绝缘电阻	Insulation Resistance	$\geq 10^{10} \Omega$
材料	Material	聚碳酸酯 Polycarbonate
工作温度范围	Limiting Temperatures	-40°C...+125°C
依据UL94阻燃等级	Flammability Acc. To UL94	V0
可拔插次数	Mechanical Working Life-mating Cycles	$\geq 500$
插针	Contacts	
材料	Material	铜合金 Copper Alloy
表面处理	Surface	镀银 Hard-Silver Plated
接触电阻	Contact Resistance	$\leq 1m\Omega$
轴向螺栓连接	Axial Screw Termination	
mm <sup>2</sup>	mm <sup>2</sup>	2.5-10mm <sup>2</sup>
AWG	AWG	14-8
拧紧力矩	Tightening Torque	1.8Nm
剥线长度	Stripping Length	8mm <sup>±1</sup>
外壳	Hoods/housings	
塑料外壳	Plastic Hoods/housings	
-材料	-material	聚碳酸酯 Polycarbonate
-依据UL94的阻燃等级	-flammability Acc. To UL 94	V0
-连锁状态下依据DIN EN60 529的防护等级	-degree Of Protection Acc. To DIN EN60 529 For Coupled Connector	IP67
金属外壳	Hoods/housings, Metal	
-材料	-material	锌合金 Zinc Die-cast
-连锁状态下依据DIN EN60 529的防护等级	-degree Of Protection Acc. To DIN EN60 529 For Coupled Connector	IP44 IP67(实现螺栓密封) is achieved with seal screw

### 电流负载能力 Current Carrying Capacity

电流负载能力所受的限制主要来自包含接插针的接插体可承受的最大温度

THQ current carrying is limited by maximum temperature of materials for Inserts and contacts including terminals.

测试和控制过程依据 Measuring and testing techniques according to DIN EN 60512-5

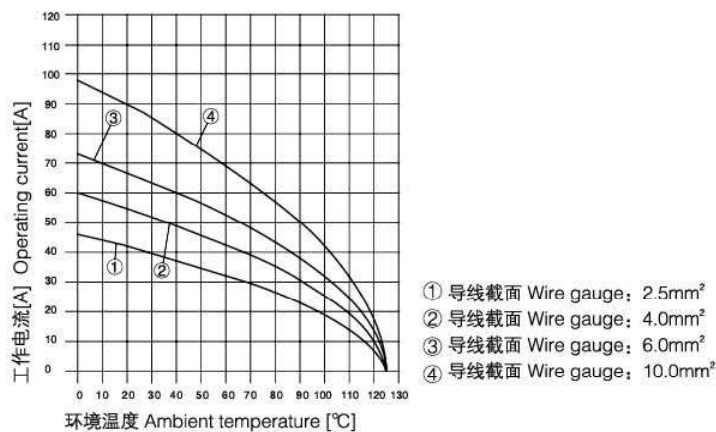

## Compact Series

# UTL-HQ-002/0 紧凑小体积型插芯 400V 40A 2+⊕

### 插芯 Inserts

外壳尺寸：匹配3A外壳,详情请参考11-05-11-11页

Hoods/Housings: size 3A,detail please find the page P11-05-P11-1

轴向螺栓连接 Axial Screw Terminal



插芯 Inserts	型号 Type	订货号 Part Number
公 Male	UTL-HQ-002.1-M(2.5-6.0mm <sup>2</sup> )	09120022653
	UTL-HQ-002.2-M(4-10mm <sup>2</sup> )	09120022651
母 Female	UTL-HQ-002.1-F(2.5-6.0mm <sup>2</sup> )	09120022753
	UTL-HQ-002.2-F(4-10mm <sup>2</sup> )	09120022751

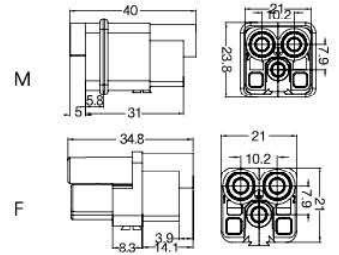

### 附件 Accessories

工具 Tools

内六角扳手  
Hexagonal driver



描述 Description	型号 Type	订货号 Part Number
用于轴向夹紧螺栓 带T型把手 For Axial Setscrew With Grip	SW-2x40	09990000363

编码元件 Coding Element



描述 Description	型号 Type	订货号 Part Number
编码、防呆 Coding、Pokayoke	CODE-Q2	09120009922



# Compact Series

## UTL-HQV-002/0 紧凑小体积型插芯

### 技术参数 Technical Characteristics

规范	Specifications	
规范	Specifications	DIN EN 60 664
		DIN EN 61 984
插芯	Inserts	
依据 EN 61 984的额定电压	Electrical Data Acc. To EN 61 984	
接插件针数	Number Of Contacts	2+PE
额定电流	Rated Current	40A
额定电压	Rated Voltage	830V
额定脉冲电压	Rated Impulse Voltage	6kV
污染程度	Pollution Degree	3
依据UL/CSA额定电压	Rated Voltage Acc.to UI CSA	600V
绝缘电阻	Insulation Resistance	$\geq 10^{10} \Omega$
材料	Material	聚碳酸酯 Polycarbonate
工作温度范围	Limiting Temperatures	-40°C...+125°C
依据UL94阻燃等级	Flammability Acc. To UL94	V0
可拔插次数	Mechanical Working Life-mating Cycles	$\geq 500$
插针	Contacts	
材料	Material	铜合金 Copper Alloy
表面处理	Surface	镀银 Hard-Silver Plated
接触电阻	Contact Resistance	$\leq 1m\Omega$
轴向螺栓连接	Axial Screw Termination	
mm <sup>2</sup>	mm <sup>2</sup>	2.5-10mm <sup>2</sup>
AWG	AWG	14-8
拧紧力矩	Tightening Torque	1.8Nm
剥线长度	Stripping Length	8mm <sup>±1</sup>
外壳	Hoods/housings	
塑料外壳	Plastic Hoods/housings	
-材料	-material	聚碳酸酯 Polycarbonate
-依据UL94的阻燃等级	-flammability Acc. To UL 94	V0
-联锁状态下依据DIN EN60 529的防护等级	-degree Of Protection Acc. To DIN EN60 529 For Coupled Connector	IP67
金属外壳	Hoods/housings, Metal	
-材料	-material	锌合金 Zinc Die-cast
-联锁状态下依据DIN EN60 529的防护等级	-degree Of Protection Acc. To DIN EN60 529 For Coupled Connector	IP44
		IP67(实现螺栓密封) is achieved with seal screw

### 电流负载能力 Current Carrying Capacity

电流负载能力所受的限制主要来自包含接插针的接插体可承受的最大温度

THQ current carrying is limited by maximum temperature of materials for Inserts and contacts including terminals.

测试和控制过程依据 Measuring and testing techniques according to DIN EN 60512-5

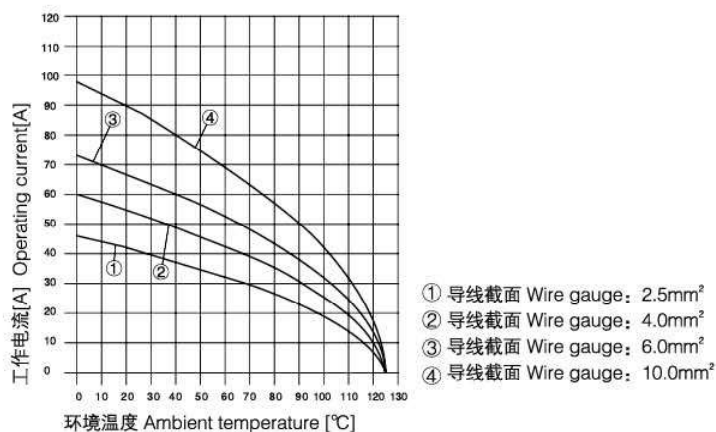

## Compact Series

# UTL-HQ-002/0 紧凑小体积型插芯 400V 40A 2+⊕

### 插芯 Inserts

外壳尺寸: 匹配3A外壳,详情请参考11-05-11-11页

Hoods/Housings: size 3A,detail please find the page P11-05-P11-11

轴向螺栓连接 Axial Screw Terminal



插芯 Inserts	型号 Type	订货号 Part Number
公 Male	UTL-HQV-002.1-M(2.5-6.0mm <sup>2</sup> )	09120022654
	UTL-HQV-002.2-M(4-10mm <sup>2</sup> )	09120022652
母 Female	UTL-HQV-002.1-F(2.5-6.0mm <sup>2</sup> )	09120022754
	UTL-HQV-002.2-F(4-10mm <sup>2</sup> )	09120022752

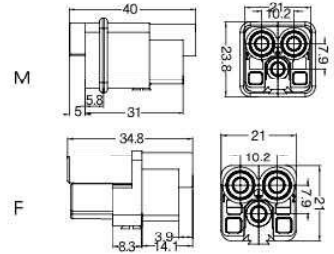

### 附件 Accessories

工具 Tools

内六角扳手  
Hexagonal driver



描述 Description	型号 Type	订货号 Part Number
用于轴向夹紧螺栓 带T型把手 For Axial Setscrew With Grip	SW-2x40	09990000363

编码元件 Coding Element



描述 Description	型号 Type	订货号 Part Number
编码、防呆 Coding, Pokayoke	CODE-Q2	09120009922

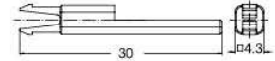

# Compact Series

## UTL-HQ-005/0 紧凑型插芯

### 技术参数 Technical Characteristics

规范	Specifications	
规范	Specifications	DIN EN 60 664
		DIN EN 61 984
插芯	Inserts	
依据 EN 61 984的额定电压	Electrical Data Acc. To EN 61 984	
接插件针数	Number Of Contacts	5+PE
额定电流	Rated Current	16A
相对地额定电压	Rated voltage conductor-ground	230V
相间额定电压	Rated voltage conductor-conductor	400V
额定脉冲电压	Rated Impulse Voltage	4kV
污染程度	Pollution Degree	3
当污染等级2时的参数	Pollution Degree 2 Also	16A 320/500V 4kV 2
依据UL/CSA额定电压	Rated Voltage Acc.to UI CSA	600V
绝缘电阻	Insulation Resistance	$\geq 10^{10} \Omega$
材料	Material	聚碳酸酯 Polycarbonate
工作温度范围	Limiting Temperatures	-40°C...+125°C
依据UL94阻燃等级	Flammability Acc. To UL94	V0
可拔插次数	Mechanical Working Life-mating Cycles	$\geq 500$
插针	Contacts	
材料	Material	铜合金 Copper Alloy
表面处理	Surface	镀银 Hard-Silver Plated 镀金 Hard-gold Plated
接触电阻	Contact Resistance	$\leq 1m\Omega$
冷压连接	Crimp Terminal	
-mm <sup>2</sup>	-mm <sup>2</sup>	0.14-2.5mm <sup>2</sup>
-AWG	-AWG	26-14
PE螺钉连接	PF Screw Terminal	
-mm <sup>2</sup>	-mm <sup>2</sup>	2.5mm <sup>2</sup>
-AWG	-AWG	14
外壳	Hoods/housings	
塑料外壳	Plastic Hoods/housings	
-材料	-material	聚碳酸酯 Polycarbonate
-依据UL94的阻燃等级	-flammability Acc. To UL 94	V0
-联锁状态下依据DIN EN60 529的防护等级	-degree Of Protection Acc. To DIN EN60 529 For Coupled Connector	IP67
金属外壳	Hoods/housings, Metal	
-材料	-material	锌合金 Zinc Die-cast
-联锁状态下依据DIN EN60 529的防护等级	-degree Of Protection Acc. To DIN EN60 529 For Coupled Connector	IP44 IP67(实现螺栓密封) is achieved with seal screw

### 电流负载能力 Current Carrying Capacity

电流负载能力所受的限制主要来自包含接插针的接插体可承受的最大温度

THQ current carrying is limited by maximum temperature of materials for Inserts and contacts including terminals.

测试和控制过程依据 Measuring and testing techniques according to DIN EN 60512-5

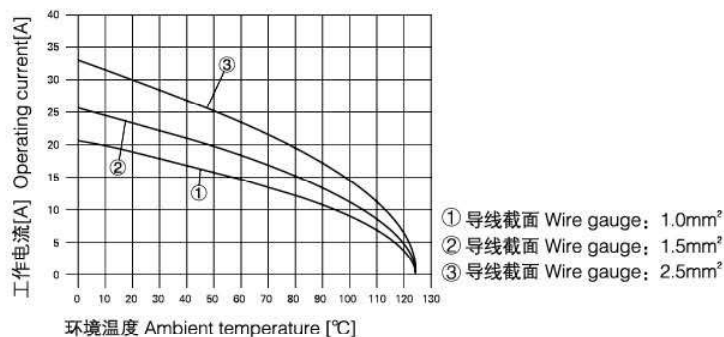

# Compact Series

## UTL-HQ-005/0 紧凑小体积型插芯 230/400V 16A 5+⊕

### 插芯 Inserts

外壳尺寸: 匹配3A外壳,详情请参考11-05-11-11页

Hoods/Housings: size 3A,detail please find the page P11-05-P11-11

冷压连接 Crimp terminal



插芯 Inserts	型号 Type	订货号 Part Number
公 Male	UTL-HQ-005/0-MC	09120053001
母 Female	UTL-HQ-005/0-FC	09120053101

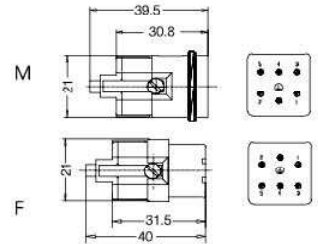

### 附件 Accessories

16A 冷压针 Crimp contacts

接触电阻 Contact resistance  $\leq 1m\Omega$   
镀银 Silver plated



镀金 Gold plated



公 Male	订货号 Part Number	母 Female	订货号 Part Number
CESM-0.37	09330006127	CESF-0.37	09330006227
CESM-0.5	09330006121	CESF-0.5	09330006220
CESM-0.75	09330006114	CESF-0.75	09330006214
CESM-1.0	09330006105	CESF-1.0	09330006205
CESM-1.5	09330006104	CESF-1.5	09330006204
CESM-2.5	09330006102	CESF-2.5	09330006202

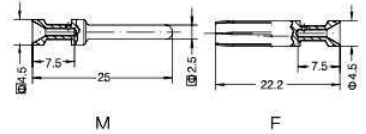

标示 Identification	线规 Wire gauge	剥线长度 Stripping length
no groove	0.14-0.37mm <sup>2</sup> AWG 26-22	7.5mm
no groove	0.5mm <sup>2</sup> AWG 20	7.5mm
1 groove	0.75mm <sup>2</sup> AWG 18	7.5mm
1 groove	1.0mm <sup>2</sup> AWG 18	7.5mm
2 groove	1.5mm <sup>2</sup> AWG 16	7.5mm
3 groove	2.5mm <sup>2</sup> AWG 14	7.5mm

保险延迟针 Relay contact

镀银 Silver plated



线规 Wire gauge(mm <sup>2</sup> )	型号 Type	订货号 Part Number
1	CESM-1.0R	09330006109
1.5	CESM-1.5R	09330006110
2.5	CESM-2.5R	09330006111

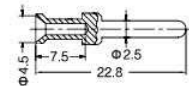

编码元件 Coding Element



描述 Description	型号 Type	订货号 Part Number
编码、防呆 Coding、Pokayoke	CODE-E	09330009954

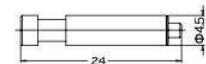

工具 Tools

冷压钳  
Crimping tool



压接线经 Wire gauge	型号 Type	订货号 Part Number
0.5-4mm <sup>2</sup>	TL02G	09990000021

压接线径: 0.14-0.37mm<sup>2</sup>请选择TL02冷压钳  
Wire gauge: 0.14-0.37mm<sup>2</sup>please select TL02 Crimping tool

退针器  
Removal tool



适用类型 For	型号 Type	订货号 Part Number
16A 冷压针 Crimp contacts	TL01	09990000059

# Compact Series

## UTL-HQ-007/0 紧凑型插芯

### 技术参数 Technical Characteristics

规范	Specifications	
规范	Specifications	DIN EN 60 664
		DIN EN 61 984
插芯	Inserts	
依据 EN 61 984的额定电压	Electrical Data Acc. To EN 61 984	
接插件针数	Number Of Contacts	7+PE
额定电流	Rated Current	10A
额定电压	Rated Voltage	400V
额定脉冲电压	Rated Impulse Voltage	6kV
污染程度	Pollution Degree	3
当污染等级2时的参数	Pollution Degree 2 Also	10A 400/690V 6kV 2
依据UL/CSA额定电压	Rated Voltage Acc.to UI CSA	600V
绝缘电阻	Insulation Resistance	$\geq 10^{10} \Omega$
材料	Material	聚碳酸酯 Polycarbonate
工作温度范围	Limiting Temperatures	-40°C...+125°C
依据UL94阻燃等级	Flammability Acc. To UL94	V0
可拔插次数	MechQnical Working Life-mating Cycles	$\geq 500$
插针	Contacts	
材料	Material	铜合金 Copper Alloy
表面处理	Surface	镀银 Hard-Silver Plated 镀金 Hard-Gold Plated
接触电阻	Contact Resistance	$\leq 3m\Omega$
冷压连接	Crimp Terminal	
-mm <sup>2</sup>	-mm <sup>2</sup>	0.14-2.5mm <sup>2</sup>
-AWG	-AWG	26-14
PE螺钉连接	PE Screw Terminal	
-mm <sup>2</sup>	-mm <sup>2</sup>	2.5mm <sup>2</sup>
-AWG	-AWG	14
外壳	Hoods/housings	
塑料外壳	Plastic Hoods/housings	
-材料	-material	聚碳酸酯 Polycarbonate
-依据UL94的阻燃等级	-flammability Acc. To UL 94	V0
-联锁状态下依据DIN EN60 529的防护等级	-degree Of Protection Acc. To DIN EN60 529 For Coupled Connector	IP67
金属外壳	Hoods/housings, Metal	
-材料	-material	锌合金 Zinc Die-cast
-联锁状态下依据DIN EN60 529的防护等级	-degree Of Protection Acc. To DIN EN60 529 For Coupled Connector	IP44 IP67(实现螺栓密封) is achieved with seal screw

### 电流负载能力 Current Carrying Capacity

电流负载能力所受的限制主要来自包含接插针的接插体可承受的最大温度

THQ current carrying is limited by maximum temperature of materials for Inserts and contacts including terminals.

测试和控制过程依据 Measuring and testing techniques according to DIN EN 60512-5

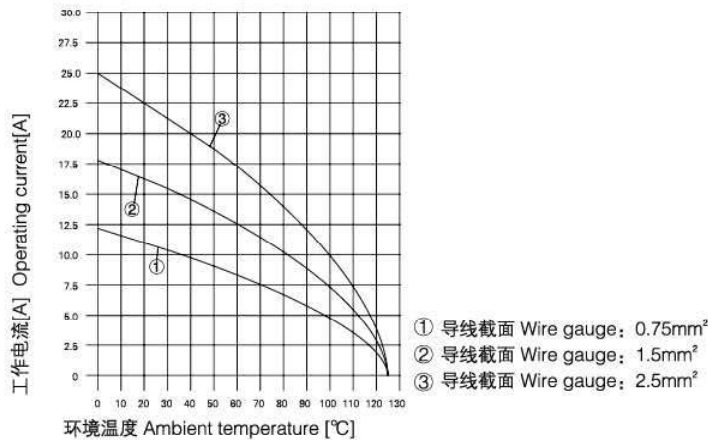



# Compact Series

## UTL-HQ-007/0 紧凑小体积型插芯 400 10A 7+⊕

### 插芯 Inserts

外壳尺寸: 匹配3A外壳, 详情请参考11-05~11-11页

Hoods/Housings: size 3A, detail please find the page P11-05-P11-11

冷压连接 Crimp terminal



插芯 Inserts	型号 Type	订货号 Part Number
公 Male	UTL-HQ-007/0-MC	09120073001
母 Female	UTL-HQ-007/0-FC	09120073101

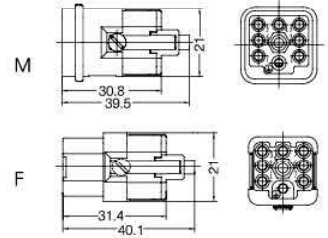

### 附件 Accessories

10A 冷压针 Crimp contacts

接触电阻 Contact resistance  $\leq 3m\Omega$

镀银 Silver plated



镀金 Gold plated



公 Male	订货号 Part Number	母 Female	订货号 Part Number
CDSM-0.37	09150006104	CDSF-0.37	09150006204
CDSM-0.5	09150006103	CDSF-0.5	09150006203
CDSM-0.75	09150006105	CDSF-0.75	09150006205
CDSM-1.0	09150006102	CDSF-1.0	09150006202
CDSM-1.5	09150006101	CDSF-1.5	09150006201
CDSM-2.5	09150006106	CDSF-2.5	09150006206
CDGM-0.37	09150006124	CDGF-0.37	09150006224
CDGM-0.5	09150006123	CDGF-0.5	09150006223
CDGM-0.75	09150006125	CDGF-0.75	09150006225
CDGM-1.0	09150006122	CDGF-1.0	09150006222
CDGM-1.5	09150006121	CDGF-1.5	09150006221
CDGM-2.5	09150006126	CDGF-2.5	09150006226

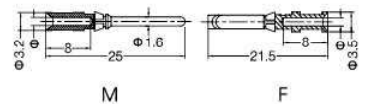

线规 Wire gauge	$\Phi$	剥线长度 Stripping length
0.14-0.37 mm <sup>2</sup>	AWG 26-22	0.9
0.5 mm <sup>2</sup>	AWG 20	1.1
0.75 mm <sup>2</sup>	AWG 18	1.3
1 mm <sup>2</sup>	AWG 18	1.45
1.5 mm <sup>2</sup>	AWG 16	1.75
2.5 mm <sup>2</sup>	AWG 14	2.25

编码元件 Coding Element



描述 Description	类别 Category	型号 Type	订货号 Part Number
编码、防呆	公 Male	CODE-Q7M	09120009901
Coding、Pokayoke	母 Female	CODE-Q7F	09120009902

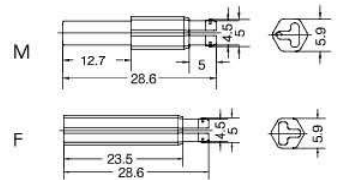

工具 Tools

冷压钳  
Crimping tool



压接线经 Wire gauge	型号 Type	订货号 Part Number
0.14-4mm <sup>2</sup>	TL02G	09990000021

退针器  
Removal tool



适用类型 For	型号 Type	订货号 Part Number
10A 冷压针 Crimp contacts	TL00	09990000059

# Compact Series

## UTL-HQ-012/0 紧凑小体积型插芯

### 技术参数 Technical Characteristics

规范	Specifications	
规范	Specifications	DIN EN 60 664
		DIN EN 61 984
插芯	Inserts	
依据 EN 61 984的额定电压	Electrical Data Acc. To EN 61 984	
接插件针数	Number Of Contacts	12+PE
额定电流	Rated Current	10A
额定电压	Rated Voltage	400V
额定脉冲电压	Rated Impulse Voltage	6kV
污染程度	Pollution Degree	3
当污染等级2时的参数	Pollution Degree 2 Also	10A 400/690V 6kV 2
依据UL/CSA额定电压	Rated Voltage Acc.to UI CSA	600V
绝缘电阻	Insulation Resistance	$\geq 10^{10} \Omega$
材料	Material	聚碳酸酯 Polycarbonate
工作温度范围	Limiting Temperatures	-40°C...+125°C
依据UL94阻燃等级	Flammability Acc. To UL94	V0
可拔插次数	MechQnical Working Life-mating Cycles	$\geq 500$
插针	Contacts	
材料	Material	铜合金 Copper Alloy
表面处理	Surface	镀银 Hard-Silver Plated 镀金 Hard-Gold Plated
接触电阻	Contact Resistance	$\leq 3m\Omega$
冷压连接	Crimp Terminal	
-mm <sup>2</sup>	-mm <sup>2</sup>	0.14-2.5mm <sup>2</sup>
-AWG	-AWG	26-14
PE螺钉连接	PE Screw Terminal	快速锁定终止 Quick Lock Termination
-mm <sup>2</sup>	-mm <sup>2</sup>	0.5-2.5mm <sup>2</sup>
-AWG	-AWG	20-14
外壳	Hoods/housings	
塑料外壳	Plastic Hoods/housings	
-材料	-material	聚碳酸酯 Polycarbonate
-依据UL94的阻燃等级	-flammability Acc. To UL 94	V0
-联锁状态下依据DIN EN60 529的防护等级	-degree Of Protection Acc. To DIN EN60 529 For Coupled Connector	IP67
金属外壳	Hoods/housings, Metal	
-材料	-material	锌合金 Zinc Die-cast
-联锁状态下依据DIN EN60 529的防护等级	-degree Of Protection Acc. To DIN EN60 529 For Coupled Connector	IP44 IP67(实现螺栓密封) is achieved with seal screw

### 电流负载能力 Current Carrying Capacity

电流负载能力所受的限制主要来自包含接插针的接插体可承受的最大温度

THQ current carrying is limited by maximum temperature of materials for Inserts and contacts including terminals.

测试和控制过程依据 Measuring and testing techniques according to DIN EN 60512-5

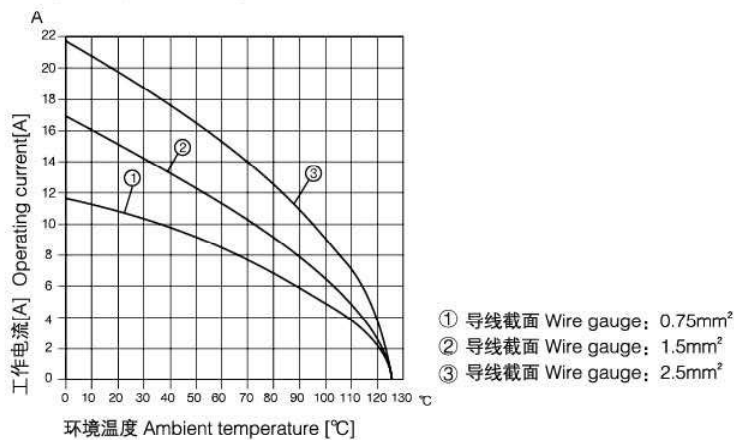

# Compact Series

## UTL-HQ-012/0 紧凑小体积型插芯 400 10A 12+⊕

### 插芯 Inserts

外壳尺寸：匹配3A外壳,详情请参考11-05-11-11页

Hoods/Housings: size 3A,detail please find the page P11-05-P11-11

冷压连接 Crimp terminal



插芯 Inserts	型号 Type	订货号 Part Number
公 Male	UTL-HQ-012/0-MC	09120123001
母 Female	UTL-HQ-012/0-FC	09120123101

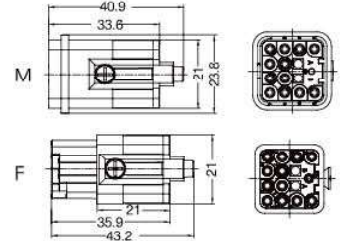

### 附件 Accessories

10A 冷压针 Crimp contacts

接触电阻 Contact resistance  $\leq 3m\Omega$

镀银 Silver plated



镀金 Gold plated



公 Male	订货号 Part Number	母 Female	订货号 Part Number
CDSM-0.37	09150006104	CDSF-0.37	09150006204
CDSM-0.5	09150006103	CDSF-0.5	09150006203
CDSM-0.75	09150006105	CDSF-0.75	09150006205
CDSM-1.0	09150006102	CDSF-1.0	09150006202
CDSM-1.5	09150006101	CDSF-1.5	09150006201
CDSM-2.5	09150006106	CDSF-2.5	09150006206

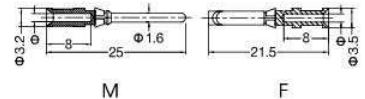

线规 Wire gauge	$\phi$	剥线长度 Stripping length
0.14-0.37 mm <sup>2</sup>	AWG 26-22	0.9
0.5 mm <sup>2</sup>	AWG 20	1.1
0.75 mm <sup>2</sup>	AWG 18	1.3
1 mm <sup>2</sup>	AWG 18	1.45
1.5 mm <sup>2</sup>	AWG 16	1.75
2.5 mm <sup>2</sup>	AWG 14	2.25

编码元件 Coding Element



描述 Description	型号 Type	订货号 Part Number
编码、防呆 Coding、Pokayoke	CODE-Q12	09120009924

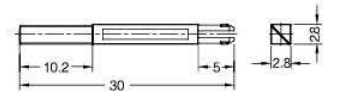

工具 Tools

冷压钳  
Crimping tool



压接线径 Wire gauge	型号 Type	订货号 Part Number
0.14-4mm <sup>2</sup>	TL02G	0999000021

退针器  
Removal tool



适用类型 For	型号 Type	订货号 Part Number
10A 冷压针 Crimp contacts	TL00	0999000059

# Compact Series

## UTL-HQ-008/0 紧凑型插芯

### 技术参数 Technical Characteristics

规范	Specifications	
规范	Specifications	DIN EN 60 664
		DIN EN 61 984
插芯	Inserts	
依据 EN 61 984的额定电压	Electrical Data Acc. To EN 61 984	
接插件针数	Number Of Contacts	8+PE
额定电流	Rated Current	16A
额定电压	Rated Voltage	500V
额定脉冲电压	Rated Impulse Voltage	6kV
污染程度	Pollution Degree	3
当污染等级2时的参数	Pollution Degree 2 Also	16A 400/690V 6kV 2
安装金属外壳时	Mounted Metal Hood	16A 230/400V 4kV 3
依据UL/CSA额定电压	Rated Voltage Acc.to UI CSA	600V
绝缘电阻	Insulation Resistance	$\geq 10^{10}\Omega$
材料	Material	聚碳酸酯 Polycarbonate
工作温度范围	Limiting Temperatures	-40°C...+125°C
依据UL94阻燃等级	Flammability Acc. To UL94	V0
可拔插次数	Mechanical Working Life-mating Cycles	$\geq 500$
插针	Contacts	
材料	Material	铜合金 Copper Alloy
表面处理	Surface	镀银 Hard-Silver Plated 镀金 Hard-Gold Plated
接触电阻	Contact Resistance	$\leq 1m\Omega$
冷压连接	Crimp Terminal	
-mm <sup>2</sup>	-mm <sup>2</sup>	0.14-2.5mm <sup>2</sup> (部分装备情况下可达到4mm <sup>2</sup> )
-AWG	-AWG	26-12
外壳	Hoods/housings	
塑料外壳	Plastic Hoods/housings	
-材料	-material	热塑性塑料 Hermoplastic
-联锁元件	-Locking element	聚酰胺(尼龙) Polyamide
-外壳密封	-Hoods/Housings seal	丁腈橡胶 NBR
-工作温度范围	-Limiting temperatures	-40°C...+125°C
-依据UL94的阻燃等级	-flammability Acc. To UL 94	V0
-联锁状态下依据DIN EN60 529的防护等级	-degree Of Protection Acc. To DIN EN60 529 For Coupled Connector	IP65
金属外壳	Hoods/housings, Metal	
-材料	-material	金属 Metal
-联锁元件	-Locking element	不锈钢 Stainless Steel
-外壳密封	-Hoods/Housings seal	丁腈橡胶 NBR
-工作温度范围	-Limiting temperatures	-40°C...+125°C
-联锁状态下依据DIN EN60 529的防护等级	-degree Of Protection Acc. To DIN EN60 529 For Coupled Connector	IP65

### 电流负载能力 Current Carrying Capacity

电流负载能力所受的限制主要来自包含接插针的接插体可承受的最大温度

THQ current carrying is limited by maximum temperature of materials for Inserts and contacts including terminals.

测试和控制过程依据 Measuring and testing techniques according to DIN EN 60512-5

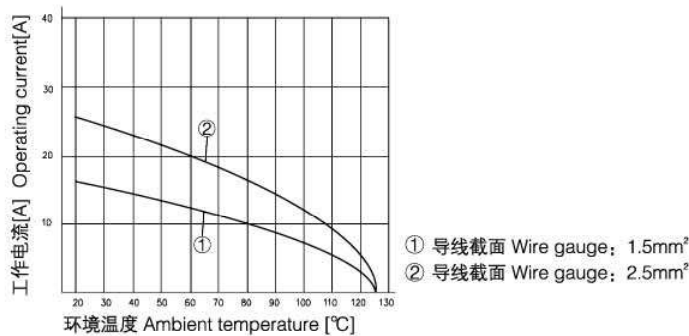

# Compact Series

## UTL-HQ-008/0 紧凑小体积型插芯 500 16A 8+⊕

### 插芯 Inserts

外壳尺寸：匹配HC外壳,详情请参考P21-01~21-08页

Hoods/Housings: size HC,detail please find the page P21-01~P21-08

冷压连接 Crimp terminal



插芯 Inserts	型号 Type	订货号 Part Number
公 Male	UTL-HQ-008/0-MC	09120083001
母 Female	UTL-HQ-008/0-FC	09120083101

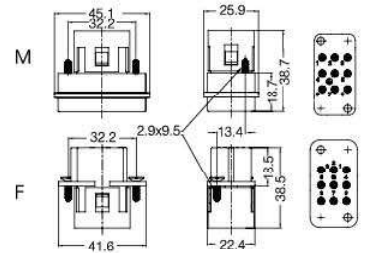

### 附件 Accessories

16A 冷压针 Crimp contacts

接触电阻 Contact resistance  $\leq 1m\Omega$   
镀银 Silver plated



镀金 Gold plated



保险延迟针 Relay contact

镀银 Silver plated



公 Male	订货号 Part Number	母 Female	订货号 Part Number
CESM-0.37	09330006127	CESF-0.37	09330006227
CESM-0.5	09330006121	CESF-0.5	09330006220
CESM-0.75	09330006114	CESF-0.75	09330006214
CESM-1.0	09330006105	CESF-1.0	09330006205
CESM-1.5	09330006104	CESF-1.5	09330006204
CESM-2.5	09330006102	CESF-2.5	09330006202
CESM-3.0	09330006106	CESF-3.0	09330006206
CESM-4.0	09330006107	CESF-4.0	09330006207

公 Male	订货号 Part Number	母 Female	订货号 Part Number
CEGM-0.37	09330006117	CEGF-0.37	09330006217
CEGM-0.5	09330006122	CEGF-0.5	09330006222
CEGM-0.75	09330006115	CEGF-0.75	09330006215
CEGM-1.0	09330006118	CEGF-1.0	09330006218
CEGM-1.5	09330006116	CEGF-1.5	09330006216
CEGM-2.5	09330006123	CEGF-2.5	09330006223
CEGM-4.0	09330006119	CEGF-4.0	09330006221

线规 Wire gauge(mm <sup>2</sup> )	型号 Type	订货号 Part Number
1	CESM-1.0R	09330006109
1.5	CESM-1.5R	09330006110
2.5	CESM-2.5R	09330006111

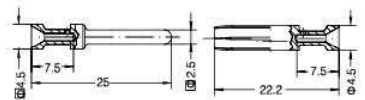

标示 Identification	线规 Wire gauge	剥线长度 Stripping length
no groove	0.14-0.37mm <sup>2</sup> AWG 26-22	7.5mm
1 groove	0.5mm <sup>2</sup> AWG 20	7.5mm
1 groove	0.75mm <sup>2</sup> AWG 18	7.5mm
2 groove	1mm <sup>2</sup> AWG 18	7.5mm
3 groove	1.5mm <sup>2</sup> AWG 16	7.5mm
3 groove	2.5mm <sup>2</sup> AWG 14	7.5mm
wide groove	3mm <sup>2</sup> AWG 12	7.5mm
no groove	4mm <sup>2</sup> AWG 12	7.5mm

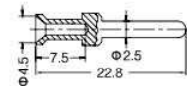

编码元件 Coding Element



描述 Description	型号 Type	订货号 Part Number
编码、防呆 Coding、Pokayoke	CODF-F	09330009954

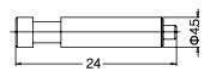

工具 Tools

冷压钳  
Crimping tool



压接线径 Wire gauge	型号 Type	订货号 Part Number
0.5-4mm <sup>2</sup>	TL02G	09990000021

压接线径: 0.14-0.37mm<sup>2</sup>请选择TL02冷压钳  
Wire gauge: 0.14-0.37mm<sup>2</sup> please select TL02 Crimping tool

退针器  
Removal tool



适用类型 For	型号 Type	订货号 Part Number
16A 冷压针 Crimp contacts	TL01	09990000059

# Compact Series

## UTL-HQ-017 紧凑型插芯

### 技术参数 Technical Characteristics

规范	Specifications	
规范	Specifications	DIN EN 60 664
		DIN EN 61 984
插芯	Inserts	
依据 EN 61 984的额定电压	Electrical Data Acc. To EN 61 984	
接插件针数	Number Of Contacts	17+PE
额定电流	Rated Current	10A
额定电压	Rated Voltage	250V
额定脉冲电压	Rated Impulse Voltage	4kV
污染程度	Pollution Degree	2
依据UL/CSA额定电压	Rated Voltage Acc.to UI CSA	250V
绝缘电阻	Insulation Resistance	$\geq 10^{10} \Omega$
材料	Material	聚碳酸酯 Polycarbonate
工作温度范围	Limiting Temperatures	-40°C...+125°C
依据UL94阻燃等级	Flammability Acc. To UL94	V0
可拔插次数	Mechanical Working Life-mating Cycles	$\geq 500$
插针	Contacts	
材料	Material	铜合金 Copper Alloy
表面处理	Surface	镀银 Hard-Silver Plated 镀金 Hard-Gold Plated
接触电阻	Contact Resistance	$\leq 3m\Omega$
冷压连接	Crimp Terminal	
-mm <sup>2</sup>	-mm <sup>2</sup>	0.14-2.5mm <sup>2</sup>
-AWG	-AWG	26-14
外壳	Hoods/housings	
塑料外壳	Plastic Hoods/housings	
-材料	-material	热塑性塑料 Thermoplastic
-联锁元件	-Locking element	聚酰胺(尼龙) Polyamide
-外壳密封	-Hoods/Housings seal	丁腈橡胶 NBR
-工作温度范围	-Limiting temperatures	-40°C...+125°C
-依据UL94的阻燃等级	-flammability Acc. To UL 94	V0
-联锁状态下依据DIN EN60 529的防护等级	-degree Of Protection Acc. To DIN EN60 529 For Coupled Connector	IP65
金属外壳	Hoods/housings, Metal	
-材料	-material	金属 Metal
-联锁元件	-Locking element	不锈钢 Stainless Steel
-外壳密封	-Hoods/Housings seal	丁腈橡胶 NBR
-工作温度范围	-Limiting temperatures	-40°C...+125°C
-联锁状态下依据DIN EN60 529的防护等级	-degree Of Protection Acc. To DIN EN60 529 For Coupled Connector	IP65

### 电流负载能力 Current Carrying Capacity

电流负载能力所受的限制主要来自包含接插针的接插体可承受的最大温度

TI IQ current carrying is limited by maximum temperature of materials for Inserts and contacts including terminals.

测试和控制过程依据 Measuring and testing techniques according to DIN EN 60512-5

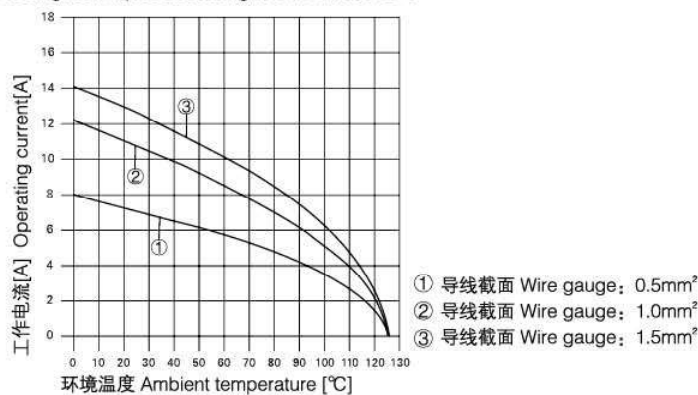

# Compact Series

## UTL-HQ-017 紧凑小体积型插芯 250 10A 17+⊕

### 插芯 Inserts

外壳尺寸: 匹配HC外壳, 详情请参考21-01~21-08页

Hoods/Housings: size HC, detail please find the page P21-01~P21-08

冷压连接 Crimp terminal



插芯 Inserts	型号 Type	订货号 Part Number
公 Male	UTL-HQ-017-MC	09120173001
母 Female	UTL-HQ-017-FC	09120173101

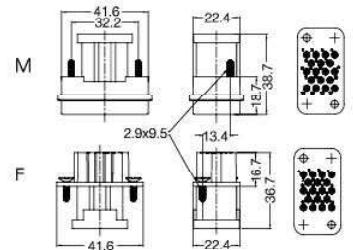

### 附件 Accessories

10A 冷压针 Crimp contacts

接触电阻 Contact resistance  $\leq 3m\Omega$

镀银 Silver plated



镀金 Gold plated



公 Male	订货号 Part Number	母 Female	订货号 Part Number
CDSM-0.37	09150006104	CDSF-0.37	09150006204
CDSM-0.5	09150006103	CDSF-0.5	09150006203
CDSM-0.75	09150006105	CDSF-0.75	09150006205
CDSM-1.0	09150006102	CDSF-1.0	09150006202
CDSM-1.5	09150006101	CDSF-1.5	09150006201
CDSM-2.5	09150006106	CDSF-2.5	09150006206
CDGM-0.37	09150006124	CDGF-0.37	09150006224
CDGM-0.5	09150006123	CDGF-0.5	09150006223
CDGM-0.75	09150006125	CDGF-0.75	09150006225
CDGM-1.0	09150006122	CDGF-1.0	09150006222
CDGM-1.5	09150006121	CDGF-1.5	09150006221
CDGM-2.5	09150006126	CDGF-2.5	09150006226

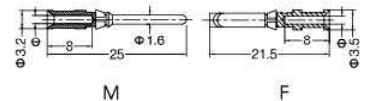

线规 Wire gauge	Φ	剥线长度 Stripping length
0.14-0.37 mm <sup>2</sup>	AWG 26-22	0.9
0.5 mm <sup>2</sup>	AWG 20	1.1
0.75 mm <sup>2</sup>	AWG 18	1.3
1 mm <sup>2</sup>	AWG 18	1.45
1.5 mm <sup>2</sup>	AWG 16	1.75
2.5 mm <sup>2</sup>	AWG 14	2.25

工具 Tools

冷压钳

Crimping tool



退针器

Removal tool



压接线经 Wire gauge	型号 Type	订货号 Part Number
0.14-4mm <sup>2</sup>	TL02G	09990000021

适用类型 For	型号 Type	订货号 Part Number
10A 冷压针 Crimp contacts	TL00	09990000059

# Compact Series

## UTL-HQ-004/2 紧凑小体积型插芯

### 技术参数 Technical Characteristics

规范	Specifications	
规范	Specifications	DIN EN 60 664
		DIN EN 61 984
插芯	Inserts	
依据 EN 61 984的额定电压	Electrical Data Acc. To EN 61 984	
接插件针数	Number Of Contacts	4/2+PE
电力区	Power Side	
额定电流	Rated Current	40A
相对地额定电压	Rated Voltage Conductor-ground	400V
相间额定电压	Rated Voltage Conductor-conductor	690V
额定脉冲电压	Rated Impulse Voltage	6kV
污染程度	Pollution Degree	3
信号区	Signal Side	
额定电流	Rated Current	10A
额定电压	Rated Voltage	250V
额定脉冲电压	Rated Impulse Voltage	4kV
污染程度	Pollution Degree	3
依据UL/CSA额定电压	Rated Voltage Acc.to UI CSA	600/250V
绝缘电阻	Insulation Resistance	$\geq 10^{10} \Omega$
材料	Material	聚碳酸酯 Polycarbonate
工作温度范围	Limiting Temperatures	-40°C...+125°C
依据UL94阻燃等级	Flammability Acc. To UL94	V0
可拔插次数	Mechanical Working Life-mating Cycles	$\geq 500$
插针	Contacts	
材料	Material	铜合金 Copper Alloy
表面处理	Surface	镀银 Hard-Silver Plated 镀金 Hard-Gold Plated
接触电阻	Contact Resistance	$\leq 0.3m\Omega$
冷压连接	Crimp Terminal	
-mm <sup>2</sup>	-mm <sup>2</sup>	1.5-6mm <sup>2</sup> / 0.14-2.5mm <sup>2</sup>
-AWG	-AWG	16-10/26-14
最大绝缘直径	Max. insulation diameter	
-强电针	- Power contacts	5mm
外壳	Hoods/housings	
塑料外壳	Plastic Hoods/housings	
-材料	-material	热塑性塑料 Hermoplastic
-联锁元件	-Locking element	聚酰胺(尼龙) Polyamide
-外壳密封	-Hoods/Housings seal	丁腈橡胶 NBR
-工作温度范围	-Limiting temperatures	-40°C...+125°C
-依据UL94的阻燃等级	-flammability Acc. To UL 94	V0
-联锁状态下依据DIN EN60 529的防护等级	-degree Of Protection Acc. To DIN EN60 529 For Coupled Connector	IP65

### 电流负载能力 Current Carrying Capacity

电流负载能力所受的限制主要来自包含接插针的接插体可承受的最大温度  
 THQ current carrying is limited by maximum temperature of materials for Inserts and contacts including terminals.  
 测试和控制过程依据 Measuring and testing techniques according to DIN EN 60512-5

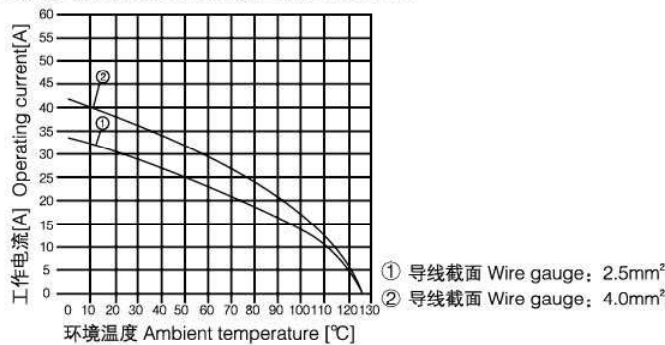



# Compact Series

## UTL-HQ-004/2 紧凑小体积型插芯 400/690V 40/10A 4/2+⊕

### 插芯 Inserts

外壳尺寸: 匹配HC外壳, 详情请参考21-01-21-08页

Hoods/Housings: size HC, detail please find the page P21-01~P21-08

冷压连接 Crimp terminal



插芯 Inserts	型号 Type	订货号 Part Number
公 Male	UTL-HQ-004/2-MC	09120063041
母 Female	UTL-HQ-004/2-FC	09120063141

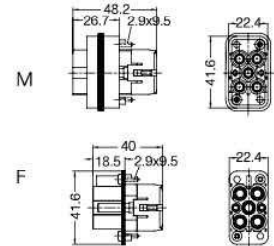

### 附件 Accessories

10A 冷压针 Crimp contacts

接触电阻 Contact resistance  $\leq 3\text{m}\Omega$   
镀银 Silver plated



镀金 Gold plated



公 Male	订货号 Part Number	母 Female	订货号 Part Number
CDSM-0.37	09150006104	CDSF-0.37	09150006204
CDSM-0.5	09150006103	CDSF-0.5	09150006203
CDSM-0.75	09150006105	CDSF-0.75	09150006205
CDSM-1.0	09150006102	CDSF-1.0	09150006202
CDSM-1.5	09150006101	CDSF-1.5	09150006201
CDSM-2.5	09150006106	CDSF-2.5	09150006206

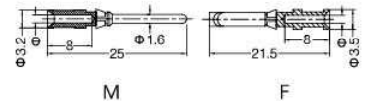

线规 Wire gauge	$\Phi$	剥线长度 Stripping length
0.14-0.37 mm <sup>2</sup> AWG 26-22	0.9	8 mm
0.5 mm <sup>2</sup> AWG 20	1.1	8 mm
0.75 mm <sup>2</sup> AWG 18	1.3	8 mm
1 mm <sup>2</sup> AWG 18	1.45	8 mm
1.5 mm <sup>2</sup> AWG 16	1.75	8 mm
2.5 mm <sup>2</sup> AWG 14	2.25	6 mm

40A 冷压针 Crimp contacts

接触电阻  $\leq 0.3\text{m}\Omega$   
Contact resistance  $\leq 0.3\text{m}\Omega$   
镀银 silver plated



公 Male	订货号 Part Number	母 Female	订货号 Part Number
CCSM-1.5	09320006104	CCSF-1.5	09320006204
CCSM-2.5	09320006105	CCSF-2.5	09320006205
CCSM-4.0	09320006107	CCSF-4.0	09320006207
CCSM-6.0	09320006108	CCSF-6.0	09320006208
CCSM-10.0	09320006109	CCSF-10.0	09320006209

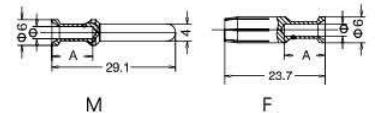

导线截面 Wire gauge	$\Phi$	剥线长度 Stripping length
1.5 mm <sup>2</sup> AWG 16	1.75	9 mm
2.5 mm <sup>2</sup> AWG 14	2.25	9 mm
4 mm <sup>2</sup> AWG 12	2.85	9.6 mm

工具 Tools

冷压钳  
Crimping tool



压接线径 Wire gauge	型号 Type	订货号 Part Number
0.14-4mm <sup>2</sup>	TL02G	09990000021
1.5-6mm <sup>2</sup>	TL02-0G	09990000110

退针器  
Removal tool



适用类型 For	型号 Type	订货号 Part Number
10A 冷压针 Crimp contacts	TL00	09990000059

适用类型 For	型号 Type	订货号 Part Number
40A 冷压针 Crimp contacts	TL06	09990000305

# 外壳 / Hood & Housing



## Hoods & Housings Contents

### 外壳部分 Hoods & Housings Contents

规格Size	页码Page
3A外壳Hoods/Housings	P114~P143
10A外壳Hoods/Housings	P144~P145
16A外壳Hoods/Housings	P146~P147
32A外壳Hoods/Housings	P148~P149
6B外壳Hoods/Housings	P150~P159
10B外壳Hoods/Housings	P160~178
16B外壳Hoods/Housings	P179~P199
24B外壳Hoods/Housings	P200~P221
32B外壳Hoods/Housings	P222~P227
48B外壳Hoods/Housings	P228~229
HC外壳Hoods/Housings	P230~238

# Hoods & Housings Contents

## 外壳部分

3A 塑料外壳 IP65 / Size 3A Plastic Hoods & Housings IP65		
材料	Material	聚碳酸酯 Polycarbonate
颜色	Colour	灰白 Light grey(RAL 7032)
联锁元件	Locking element	
-联锁方式	-Lever type	塑料弹性压合 Lever,plastic
-材料	-Material	聚酰胺 Polyamide
密封元件	Hoods & Housings seal	NBR
适用温度范围	Limiting temperatures	-40...+125°C
阻燃等级	Flammability acc. to UL 94	V0
防护等级(联锁状态,EN60529)	Degree of protection acc.to DIN EN 60 529 for coupled connector	IP65

塑料外壳 IP65 / Plastic Hoods & Housings IP65		
材料	Material	PA+20GF
颜色	Colour	深蓝色 Prussian blue
联锁元件	Locking element	
-联锁方式	-Lever type	塑料弹性压合 Lever,plastic
-材料	-Material	PA+20GF
密封元件	Hoods & Housings seal	NBR
适用温度范围	Limiting temperatures	-40...+125°C
阻燃等级	Flammability acc. to UL 94	V0
防护等级(联锁状态,EN60529)	Degree of protection acc.to DIN EN 60 529 for coupled connector	IP65

3A 金属外壳 IP65 / Size 3A Metal Hoods & Housings IP65		
材料	Material	铸锌 zinc die-cast
颜色	Colour	灰色 Grey
联锁元件	Locking element	
-联锁方式	-Lever type	金属弹性压合 Lever
-材料	-Material	金属(铁)镀锌 metal galvanized/nickel plating
密封元件	Hoods & Housings seal	NBR
适用温度范围	Limiting temperatures	-40...+125°C
阻燃等级	Flammability acc. to UL 94	V0
防护等级(联锁状态,EN60529)	Degree of protection acc.to DIN EN 60 529 for coupled connector	IP65

金属外壳 IP65 / Metal Hoods & Housings IP65		
材料	Material	铸铝合金 Aluminium die-cast,corrosion resistant
颜色	Colour	灰色 Grey
联锁元件	Locking element	
-联锁方式	-Lever type	金属弹性压合 Lever
-材料	-Material	金属(铁)镀锌 metal galvanized/nickel plating
密封元件	Hoods & Housings seal	NBR
适用温度范围	Limiting temperatures	-40...+125°C
阻燃等级	Flammability acc. to UL 94	V0
防护等级(联锁状态,EN60529)	Degree of protection acc.to DIN EN 60 529 for coupled connector	IP65

3A 高防护外壳 IP68 / Size 3A Pressure tight Hoods & Housings IP68		
表面处理	Surface	喷涂/镀铬 Epoxy power paint/Chromated
材料	Material	铸锌 zinc die-cast
颜色	Colour	黑色/灰色 Black or grey
联锁元件	Locking element	
-联锁方式	-Lever type	螺栓连接 Screw locking
-材料	-Material	不锈钢 Stainless steel
密封元件	Hoods & Housings seal	NBR
适用温度范围	Limiting temperatures	-40...+125°C
阻燃等级	Flammability acc. to UL 94	V0
防护等级(联锁状态,EN60529)	Degree of protection acc.to DIN EN 60 529 for coupled connector	IP68

# Hoods & Housings Contents

## 外壳部分

耐腐蚀(高环境)外壳 IP65 /		
表面处理	Surface	环氧粉末涂料 Epoxy powder
材料	Material	铸铝合金 Aluminium die-cast,corrosion resistant
颜色	Colour	RAL 9005(黑色Black)
联锁元件	Locking element	
-联锁方式	-Lever type	金属弹性压合 Lever
-材料	-Material	不锈钢 Stainless steel
密封元件	Hoods & Housings seal	NBR
适用温度范围	Limiting temperatures	-40...+125°C
阻燃等级	Flammability acc. to UL 94	V0
防护等级(联锁状态,EN60529)	Degree of protection acc.to DIN EN 60 529 for coupled connector	IP65

EMC电磁兼容外壳 / EMC Electromagnetic Compatibility Hoods & Housings IP65		
材料	Material	铸锌 zinc die-cast
颜色	Colour	
联锁元件	Locking element	
-联锁方式	-Lever type	金属(铁)弹性压合/螺栓连接 Lever/screw locking
-材料	-Material	金属(铁)镀锌 metal galvanized/nickel plating
密封元件	Hoods & Housings seal	NBR
适用温度范围	Limiting temperatures	-40...+125°C
阻燃等级	Flammability acc. to UL 94	V0
防护等级(联锁状态,EN60529)	Degree of protection acc.to DIN EN 60 529 for coupled connector	IP65

高防护外壳 IP68 / Pressure tight Hoods & Housings IP68		
材料	Material	铸铝合金 Aluminium die-cast,corrosion resistant
颜色	Colour	黑色或灰色 Black or grey
联锁元件	Locking element	
-联锁方式	-Lever type	螺栓连接 Screw locking
-材料	-Material	不锈钢 Stainless steel
密封元件	Hoods & Housings seal	NBR
适用温度范围	Limiting temperatures	-40...+125°C
阻燃等级	Flammability acc. to UL 94	V0
防护等级(联锁状态,EN60529)	Degree of protection acc.to DIN EN 60 529 for coupled connector	IP68

UTL-HC 金属外壳 IP65 / HC Metal Hoods & Housings IP65		
表面处理	Surface	喷涂/镀铬/镀镍 Epoxy power paint/Chromated/nickel
材料	Material	铸锌 zinc die-cast
颜色	Colour	黑色/黑色/亚光镍 Black/brushed nickel
联锁元件	Locking element	
-联锁方式	-Lever type	金属弹性压合 Lever
-材料	-Material	不锈钢 Stainless steel
密封元件	Hoods & Housings seal	NBR
适用温度范围	Limiting temperatures	-40...+125°C
阻燃等级	Flammability acc. to UL 94	V0
防护等级(联锁状态,EN60529)	Degree of protection acc.to DIN EN 60 529 for coupled connector	IP65

UTL-HC 塑料外壳 IP65 / HCPlastic Hoods & Housings IP65		
材料	Material	聚碳酸酯 Polycarbonate
颜色	Colour	灰白 Light grey(RAL 7032)
联锁元件	Locking element	
-联锁方式	-Lever type	塑料弹性压合 Lever,plastic
-材料	-Material	聚酰胺 Polyamide
密封元件	Hoods & Housings seal	NBR
适用温度范围	Limiting temperatures	-40...+125°C
阻燃等级	Flammability acc. to UL 94	V0
防护等级(联锁状态,EN60529)	Degree of protection acc.to DIN EN 60 529 for coupled connector	IP65

# Hoods & Housings Contents

## 外壳部分

3A 塑料外壳 IP65 / Size 3A Plastic Hoods & Housings IP65		
材料	Material	聚碳酸酯 Polycarbonate
颜色	Colour	灰白 Light grey(RAL 7032)
联锁元件	Locking element	
-联锁方式	-Lever type	塑料弹性压合 Lever,plastic
-材料	-Material	聚酰胺 Polyamide
密封元件	Hoods & Housings seal	NBR
适用温度范围	Limiting temperatures	-40...+125°C
阻燃等级	Flammability acc. to UL 94	V0
防护等级(联锁状态,EN60529)	Degree of protection acc.to DIN EN 60 529 for coupled connector	IP65

塑料外壳 IP65 / Plastic Hoods & Housings IP65		
材料	Material	PA+20GF
颜色	Colour	深蓝色 Prussian blue
联锁元件	Locking element	
-联锁方式	-Lever type	塑料弹性压合 Lever,plastic
-材料	-Material	PA+20GF
密封元件	Hoods & Housings seal	NBR
适用温度范围	Limiting temperatures	-40...+125°C
阻燃等级	Flammability acc. to UL 94	V0
防护等级(联锁状态,EN60529)	Degree of protection acc.to DIN EN 60 529 for coupled connector	IP65

3A 金属外壳 IP65 / Size 3A Metal Hoods & Housings IP65		
材料	Material	铸锌 zinc die-cast
颜色	Colour	灰色 Grey
联锁元件	Locking element	
-联锁方式	-Lever type	金属弹性压合 Lever
-材料	-Material	金属(铁)镀锌 metal galvanized/nickel plating
密封元件	Hoods & Housings seal	NBR
适用温度范围	Limiting temperatures	-40...+125°C
阻燃等级	Flammability acc. to UL 94	V0
防护等级(联锁状态,EN60529)	Degree of protection acc.to DIN EN 60 529 for coupled connector	IP65

金属外壳 IP65 / Metal Hoods & Housings IP65		
材料	Material	铸铝合金 Aluminium die-cast,corrosion resistant
颜色	Colour	灰色 Grey
联锁元件	Locking element	
-联锁方式	-Lever type	金属弹性压合 Lever
-材料	-Material	金属(铁)镀锌 metal galvanized/nickel plating
密封元件	Hoods & Housings seal	NBR
适用温度范围	Limiting temperatures	-40...+125°C
阻燃等级	Flammability acc. to UL 94	V0
防护等级(联锁状态,EN60529)	Degree of protection acc.to DIN EN 60 529 for coupled connector	IP65

3A 高防护外壳 IP68 / Size 3A Pressure tight Hoods & Housings IP68		
表面处理	Surface	喷涂/镀铬 Epoxy power paint/Chromated
材料	Material	铸锌 zinc die-cast
颜色	Colour	黑色/灰色 Black or grey
联锁元件	Locking element	
-联锁方式	-Lever type	螺栓连接 Screw locking
-材料	-Material	不锈钢 Stainless steel
密封元件	Hoods & Housings seal	NBR
适用温度范围	Limiting temperatures	-40...+125°C
阻燃等级	Flammability acc. to UL 94	V0
防护等级(联锁状态,EN60529)	Degree of protection acc.to DIN EN 60 529 for coupled connector	IP68

# Hoods & Housings Contents

## 外壳部分

耐腐蚀(高环境)外壳 IP65 /		
表面处理	Surface	环氧粉末涂料 Epoxy powder
材料	Material	铸铝合金 Aluminium die-cast,corrosion resistant
颜色	Colour	RAL 9005(黑色Black)
联锁元件	Locking element	
-联锁方式	-Lever type	金属弹性压合 Lever
-材料	-Material	不锈钢 Stainless steel
密封元件	Hoods & Housings seal	NBR
适用温度范围	Limiting temperatures	-40...+125°C
阻燃等级	Flammability acc. to UL 94	V0
防护等级(联锁状态,EN60529)	Degree of protection acc.to DIN EN 60 529 for coupled connector	IP65

EMC电磁兼容外壳 / EMC Electromagnetic Compatibility Hoods & Housings IP65		
材料	Material	铸锌 zinc die-cast
颜色	Colour	
联锁元件	Locking element	
-联锁方式	-Lever type	金属(铁)弹性压合/螺栓连接 Lever/screw locking
-材料	-Material	金属(铁)镀锌 metal galvanized/nickel plating
密封元件	Hoods & Housings seal	NBR
适用温度范围	Limiting temperatures	-40...+125°C
阻燃等级	Flammability acc. to UL 94	V0
防护等级(联锁状态,EN60529)	Degree of protection acc.to DIN EN 60 529 for coupled connector	IP65

高防护外壳 IP68 / Pressure tight Hoods & Housings IP68		
材料	Material	铸铝合金 Aluminium die-cast,corrosion resistant
颜色	Colour	黑色或灰色 Black or grey
联锁元件	Locking element	
-联锁方式	-Lever type	螺栓连接 Screw locking
-材料	-Material	不锈钢 Stainless steel
密封元件	Hoods & Housings seal	NBR
适用温度范围	Limiting temperatures	-40...+125°C
阻燃等级	Flammability acc. to UL 94	V0
防护等级(联锁状态,EN60529)	Degree of protection acc.to DIN EN 60 529 for coupled connector	IP68

UTL-HC 金属外壳 IP65 / HC Metal Hoods & Housings IP65		
表面处理	Surface	喷涂/镀铬/镀镍 Epoxy power paint/Chromated/nickeli
材料	Material	铸锌 zinc die-cast
颜色	Colour	黑色/黑色/亚光镍 Black/brushed nickel
联锁元件	Locking element	
-联锁方式	-Lever type	金属弹性压合 Lever
-材料	-Material	不锈钢 Stainless steel
密封元件	Hoods & Housings seal	NBR
适用温度范围	Limiting temperatures	-40...+125°C
阻燃等级	Flammability acc. to UL 94	V0
防护等级(联锁状态,EN60529)	Degree of protection acc.to DIN EN 60 529 for coupled connector	IP65

UTL-HC 塑料外壳 IP65 / HCPlastic Hoods & Housings IP65		
材料	Material	聚碳酸酯 Polycarbonate
颜色	Colour	灰白 Light grey(RAL 7032)
联锁元件	Locking element	
-联锁方式	-Lever type	塑料弹性压合 Lever,plastic
-材料	-Material	聚酰胺 Polyamide
密封元件	Hoods & Housings seal	NBR
适用温度范围	Limiting temperatures	-40...+125°C
阻燃等级	Flammability acc. to UL 94	V0
防护等级(联锁状态,EN60529)	Degree of protection acc.to DIN EN 60 529 for coupled connector	IP65





# Passic Hoods & Housings

## 3A 塑料外壳

**防护等级 Degree of protection: IP65**

防护盖 Protection covers





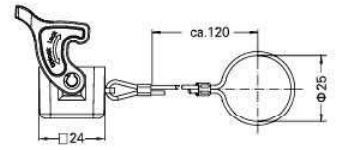

接线方式 Connect way	型号 Type	订货号 Part Number
	UTL-H3A-CV-1L/1M (配公芯 for male insert)	09200035442
	UTL-H3A-CV-1L/1F (配母芯 for female insert)	09200035441



防护盖 Protection covers



接线方式 Connect way	型号 Type	订货号 Part Number
	UTL-H3A-CV-2B/1M (配公芯 for male insert)	09200035448
	UTL-H3A-CV-2B/2M (配公芯 for male insert)	09200035446
	UTL-H3A-CV-2B/1F (配母芯 for female insert)	09200035447
	UTL-H3A-CV-2B/2F (配母芯 for female insert)	09200035445

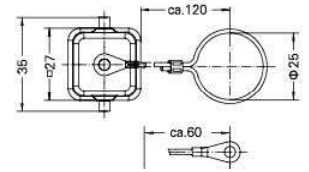

# Metal Hoods & Housings

## 3A 金属外壳

### 防护等级 Degree of protection: IP65

上壳 侧出线 Hoods, side entry



螺纹 Thread	型号 Type	订货号 Part Number
M20	UTL-H3A-SE-2B-M20	19200031640
PG11	UTL-H3A-SE-2B-PG11	09200031640

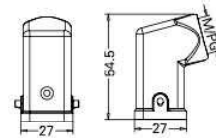

上壳 顶出线 Hoods, top entry



螺纹 Thread	型号 Type	订货号 Part Number
M20	UTL-H3A-TE-2B-M20	19200031440
PG11	UTL-H3A-TE-2B-PG11	09200031440
PG13.5	UTL-H3A-TE-2B-PG13.5	09200031441

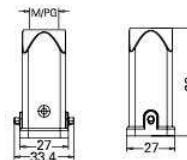

新增M25新品, 详见P11-09 (New M25 products, see P11-09)

不封底下壳 Housings, bulkhead mounting



螺纹 Thread	型号 Type	订货号 Part Number
---	UTL-H3A-BK-1L	09200030301

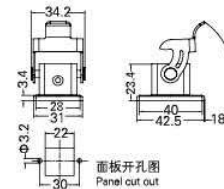

不封底下壳 Housings, bulkhead mounting



螺纹 Thread	型号 Type	订货号 Part Number
---	UTL-H3A-BK-1L-MCV/M (配公芯for male insert)	09200030305
---	UTL-H3A-BK-1L-MCV/F (配母芯for female insert)	09200030306

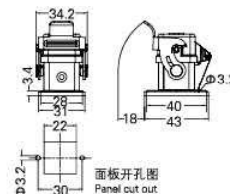

不封底下壳 Housings, bulkhead mounting



螺纹 Thread	型号 Type	订货号 Part Number
---	UTL-H3A-BK-1L-SE	09200030801

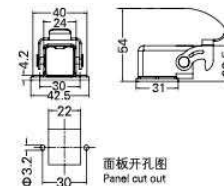

封底下壳 Housings, surface mounting



螺纹 Thread	型号 Type	订货号 Part Number
M20	UTL-H3A-SF-1L-M20	19200031250
PG11	UTL-H3A-SF-1L-PG11	09200031250
PG13.5	UTL-H3A-SF-1L-PG13.5	09200031251
底部封闭 Bottom closed		
M20	UTL-H3A.BC-SF-1L-M20	19200031252
Pg11	UTL-H3A.BC-SF-1L-PG11	09200031252
PG13.5	UTL-H3A.BC-SF-1L-PG13.5	09200031253

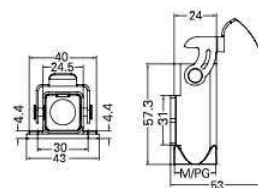

飞线下壳 Housings, cable to cable



螺纹 Thread	型号 Type	订货号 Part Number
M20	UTL-H3A-CCT-1L-M20	19200031750
PG11	UTL-H3A-CCT-1L-PG11	09200031750
PG13.5	UTL-H3A-CCT-1L-PG13.5	09200031751

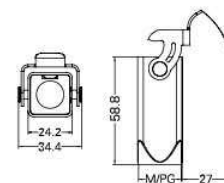

# Metal Hoods & Housings

## 3A 金属外壳

### 防护等级 Degree of protection: IP65

上壳 侧出线 Hoods, side entry



螺纹 Thread	型号 Type	订货号 Part Number
M20	UTL-EMC.H3A-SE-2B-M20	19620031640
PG11	UTL-EMC.H3A-SE-2B-PG11	09620031640

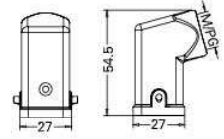

上壳 顶出线 Hoods, top entry



螺纹 Thread	型号 Type	订货号 Part Number
M20	UTL-EMC.H3A-TE-2B-M20	19620031440
PG11	UTL-EMC.H3A-TE-2B-PG11	09620031440

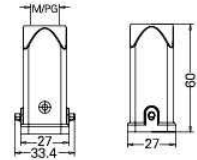

不封底下壳 Housings, bulkhead mounting



螺纹 Thread	型号 Type	订货号 Part Number
---	UTL-EMC.H3A-BK-1L	09620030301

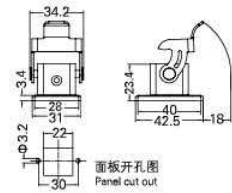

不封底下壳 Housings, bulkhead mounting



螺纹 Thread	型号 Type	订货号 Part Number
---	UTL-EMC.H3A-BK-1L-MCV/M (配公芯 for male insert)	09620030305
---	UTL-EMC.H3A-BK-1L-MCV/F (配母芯 for female insert)	09620030306

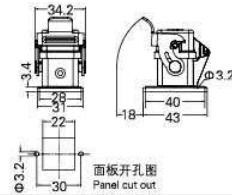

不封底下壳 Housings, bulkhead mounting



螺纹 Thread	型号 Type	订货号 Part Number
---	UTL-EMC.H3A-BK-1L-SE	09620030801

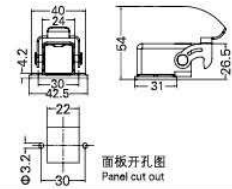

封底下壳 Housings, surface mounting



螺纹 Thread	型号 Type	订货号 Part Number
M20	UTL-EMC.H3A-SF-1L-M20	19620031250
PG11	UTL-EMC.H3A-SF-1L-PG11	09620031250

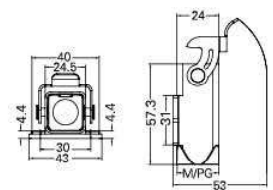

飞线下壳 Housings, cable to cable



螺纹 Thread	型号 Type	订货号 Part Number
M20	UTL-EMC.H3A-CCT-1L-M20	19620031750
PG11	UTL-EMC.H3A-CCT-1L-PG11	09620031750

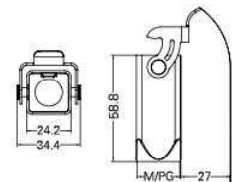

# Metal Hoods & Housings

## 3A 金属外壳

**防护等级 Degree of protection: IP65**

防护盖 Protection covers



接线方式 Connect way	型号 Type	订货号 Part Number
	UTL-H3A-MCV-1L/1M (配公芯 for male insert)	09200035422
	UTL-H3A-MCV-1L/1F (配母芯 for female insert)	09200035421

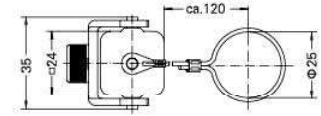

防护盖 Protection covers



接线方式 Connect way	型号 Type	订货号 Part Number
	UTL-H3A-MCV-2B/1M (配公芯 for male insert)	09200035426
	UTL-H3A-MCV-2B/2M (配公芯 for male insert)	09200035425
	UTL-H3A-MCV-2B/1F (配母芯 for female insert)	09200035428
	UTL-H3A-MCV-2B/2F (配母芯 for female insert)	09200035427

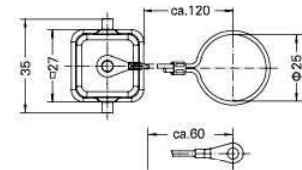

上壳 顶出线 Hoods, top entry

NEW



螺纹 Thread	型号 Type	订货号 Part Number
M25	UTL-H3A-TE-2B-M25	19200031441

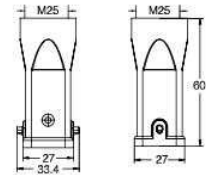

# Pressure tight Hoods & Housings

## 3A 高防护外壳

喷涂/镀铬 Epoxy power paint/Chromated 防护等级 Degree of protection: IP65 H version

上壳 顶出线 Hoods, top entry



螺纹 Thread	型号 Type	订货号 Part Number
M20	喷涂·螺栓联锁 Epoxy power paint·Screw locking	UTL-HP3A/H-TE-2S-M20 19407030410
PG13.5	喷涂·螺栓联锁 Epoxy power paint·Screw locking	UTL-HP3A/H-TE-2S-PG13.5 09407030302
M20	喷涂·轴销联锁 Epoxy power paint·Toggle locking	UTL-HP3A/H-TE-2T-M20 19407030400
PG13.5	喷涂·轴销联锁 Epoxy power paint·Toggle locking	UTL-HP3A/H-TE-2T-PG13.5 09407030402
M20	镀铬·螺栓联锁 Chromated·Screw locking	UTL-C.HP3A/H-TE-2S-M20 19400030410
PG13.5	镀铬·螺栓联锁 Chromated·Screw locking	UTL-C.HP3A/H-TE-2S-PG13.5 09400030302
M20	镀铬·轴销联锁 Chromated·Toggle locking	UTL-C.HP3A/H-TE-2T-M20 19400030400
PG13.5	镀铬·轴销联锁 Chromated·Toggle locking	UTL-C.HP3A/H-TE-2T-PG13.5 09400030402

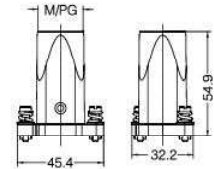

不封底下壳 Housings, bulkhead mounting\*



螺纹 Thread	型号 Type	订货号 Part Number
---	喷涂·螺栓联锁 Epoxy power paint·Screw locking	UTL-HP3A/H-BK-2H 09407030311
---	喷涂·轴销联锁 Epoxy power paint·Toggle locking	UTL-HP3A/H-BK-2T 09407030301
---	镀铬·螺栓联锁 Chromated·Screw locking	UTL-C.HP3A/H-BK-2H 09400030311
---	镀铬·轴销联锁 Chromated·Toggle locking	UTL-C.HP3A/H-BK-2T 09400030301

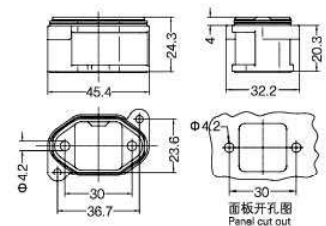

适配器 适用不封底下壳 Adaptor for Housings\*



螺纹 Thread	型号 Type	订货号 Part Number
---	喷涂 Epoxy power paint	UTL-HP3A/H-BK-SE 09407030902
---	镀铬 Chromated	UTL-C.HP3A/H-BK-SE 09400030902

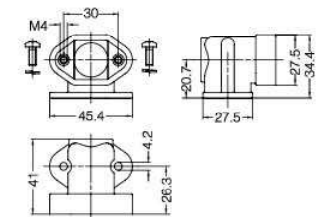

封底下壳 Housings, surface mounting



螺纹 Thread	型号 Type	订货号 Part Number
---	喷涂·螺栓联锁 Epoxy power paint·Screw locking	UTL-HP3A/H-SF-2H-M20 19407030950
PG13.5	喷涂·螺栓联锁 Epoxy power paint·Screw locking	UTL-HP3A/H-SF-2H-PG13.5 09407030502
M20	镀铬·螺栓联锁 Chromated·Screw locking	UTL-C.HP3A/H-SF-2H-M20 19400030950
PG13.5	镀铬·螺栓联锁 Chromated·Screw locking	UTL-C.HP3A/H-SF-2H-PG13.5 09407030602

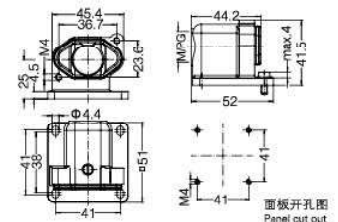

不封底下壳 Housings, bulkhead mounting



螺纹 Thread	型号 Type	订货号 Part Number
---	喷涂·螺栓联锁 Epoxy power paint·Screw locking	UTL-HP3A/H-SF-2H 09407030950
---	镀铬·螺栓联锁 Chromated·Screw locking	UTL-C.HP3A/H-SF-2H 09400030950

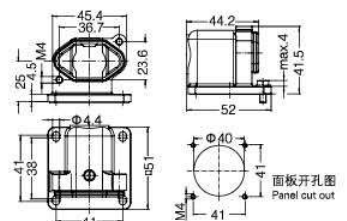

# Pressure tight Hoods & Housings

## 3A 高防护外壳

喷涂/镀铬 Epoxy power paint/Chromated 防护等级 Degree of protection: IP65 H version

上壳 顶出线 高结构 Hoods, top entry, high construction



螺纹 Thread	型号 Type	订货号 Part Number
M25	喷涂·螺栓联锁 Epoxy power paint · Screw locking UTL-HP3A/H-TEH-2S-M25	19407030411
M25	喷涂·轴销联锁 Epoxy power paint · Toggle locking UTL-HP3A/H-TEH-2T-M25	19407030500
M25	镀铬·螺栓联锁 Chromated · Screw locking UTL-C.HP3A/H-TEH-2S-M25	19400030411
M25	镀铬·轴销联锁 Chromated · Toggle locking UTL-C.HP3A/H-TEH-2T-M25	19400030500

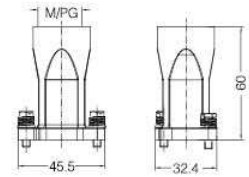

防护盖 Protection covers



接线方式 Connect way	型号 Type	订货号 Part Number
---	喷涂·螺栓联锁 Epoxy power paint · Screw locking UTL-HP3A/H-MCV-2S	09407030501
⊕	喷涂·轴销联锁 Epoxy power paint · Toggle locking UTL-HP3A/H-MCV-2T	09407030301
⊕	镀铬·螺栓联锁 Chromated · Screw locking UTL-C.HP3A/H-MCV-2S	09400030501
⊕	镀铬·轴销联锁 Chromated · Toggle locking UTL-C.HP3A/H-MCV-2T	09400030301

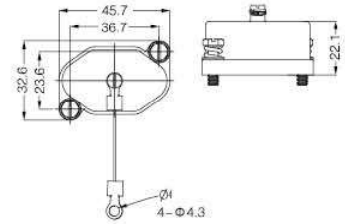

防护等级 Degree of protection: IP68

W version

上壳 顶出线 Hoods, top entry



螺纹 Thread	型号 Type	订货号 Part Number
M20	UTL-HP3A-TE-2S-M20	19407031440
PG11	HP3A-TE-2S-PG11	09407031440

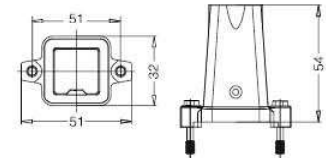

不封底下壳 Housings, bulkhead mounting



螺纹 Thread	型号 Type	订货号 Part Number
---	UTL-HP3A-BK-2H	09407030308

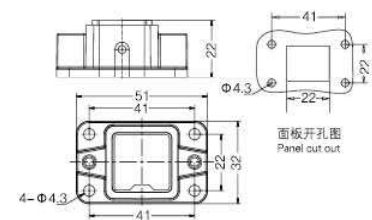

# Metal Hoods & Housings

## 10A 金属外壳

**防护等级 Degree of protection: IP65**

上壳 侧出线 Hoods, side entry



螺纹 Thread	型号 Type	订货号 Part Number
M20	UTL-H10A-SE-2B-M20	19200101540
PG16	UTL-H10A-SE-2B-PG16	09200101541

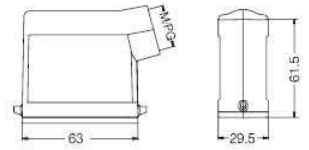

上壳 侧出线 高结构 Hoods, side entry, high construction



螺纹 Thread	型号 Type	订货号 Part Number
M25	UTL-H10A-SEH-2B-M25	19200100546
PG16	UTL-H10A-SEH-2B-PG16	09200100540
PG21	UTL-H10A-SEH-2B-PG21	09200100541

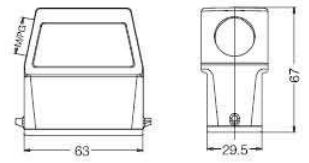

上壳 顶出线 Hoods, top entry



螺纹 Thread	型号 Type	订货号 Part Number
M20	UTL-H10A-TE-2B-M20	19200101440
PG13.5	UTL-H10A-TE-2B-PG13.5	09200101440

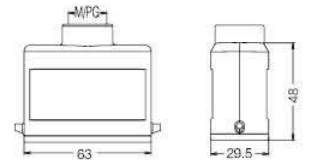

上壳 顶出线 高结构 Hoods, top entry, high construction



螺纹 Thread	型号 Type	订货号 Part Number
M25	UTL-H10A-TEH-2B-M25	19200100446
PG16	UTL-H10A-TEH-2B-PG16	09200100440
PG21	UTL-H10A-TEH-2B-PG21	09200100441

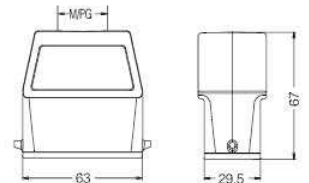

不封底下壳 Housings, bulkhead mounting



螺纹 Thread	型号 Type	订货号 Part Number
---	UTL-H10A-BK-1L	09200100301
---	带塑料盖 With plastic cover	
---	UTL-H10A-BK-1L-CV	09200100321
---	带金属盖 With metal cover	
---	UTL-H10A-BK-1L-MCV	09200100331

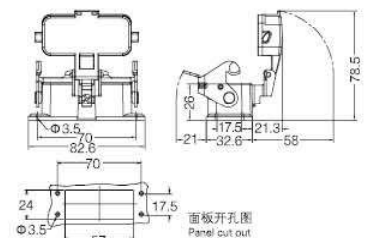

# Metal Hoods & Housings

## 10A 金属外壳

**防护等级 Degree of protection: IP65**

封底下壳 Housings, surface mounting



螺纹 Thread	型号 Type	订货号 Part Number
M20	UTL-H10A-SF-1L-M20	19200100250
2M20	UTL-H10A-SF-1L-2M20	19200100290
M25	UTL-H10A-SF-1L-M25	19200100251
PG16	UTL-H10A-SF-1L-PG16	09200100251
2PG16	UTL-H10A-SF-1L-2PG16	09200100291
PG21	UTL-H10A-SF-1L-PG21	09200100252
带塑料盖 With plastic cover		
M20	UTL-H10A-SF-1L-CV-M20	19200100294
2M20	UTL-H10A-SF-1L-CV-2M20	19200100295
M25	UTL-H10A-SF-1L-CV-M25	19200100296
PG16	UTL-H10A-SF-1L-CV-PG16	09200100221
2PG16	UTL-H10A-SF-1L-CV-2PG16	09200100296
PG21	UTL-H10A-SF-1L-CV-PG21	09200100231
带金属盖 With metal cover		
M20	UTL-H10A-SF-1L-MCV-M20	19200100694
2M20	UTL-H10A-SF-1L-MCV-2M20	19200100695
M25	UTL-H10A-SF-1L-MCV-M25	19200100696
PG16	UTL-H10A-SF-1L-MCV-PG16	09200100651
2PG16	UTL-H10A-SF-1L-MCV-2PG16	09200100691
PG21	UTL-H10A-SF-1L-MCV-PG21	09200100652

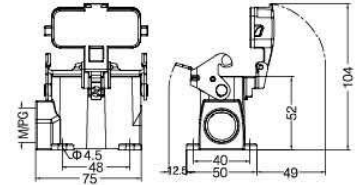

防护盖 Protection covers



接线方式 Connect way	描述 Applications	型号 Type	订货号 Part Number
	金属盖/用于上壳 For hoods	UTL-H10A-MCV-1L.1	09200105423

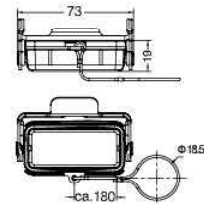

防护盖 Protection covers



接线方式 Connect way	描述 Applications	型号 Type	订货号 Part Number
	金属盖/用于下壳 For housings	UTL-H10A-MCV-2B/1S	09200105424
	金属盖/用于下壳 For housings	UTL-H10A-MCV-2B/2S	09200105425

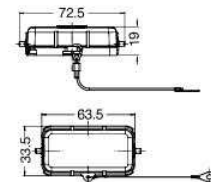



# Metal Hoods & Housings

## 16A 金属外壳

**防护等级 Degree of protection: IP65**

上壳 侧出线 Hoods, side entry



螺纹 Thread	型号 Type	订货号 Part Number
M20	UTL-H16A-SE-2B-M20	19200161540
PG16	UTL-H16A-SE-2B-PG16	09200161541

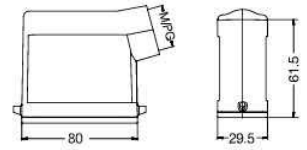

上壳 侧出线 高结构 Hoods, side entry, high construction



螺纹 Thread	型号 Type	订货号 Part Number
M25	UTL-H16A-SEH-2B-M25	19200160546
PG16	UTL-H16A-SEH-2B-PG16	09200160540
PG21	UTL-H16A-SEH-2B-PG21	09200160541

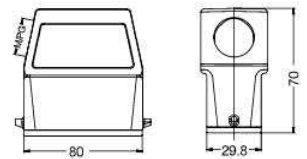

上壳 顶出线 Hoods, top entry



螺纹 Thread	型号 Type	订货号 Part Number
M20	UTL-H16A-TE-2B-M20	19200161440
PG16	UTL-H16A-TE-2B-PG16	09200161440

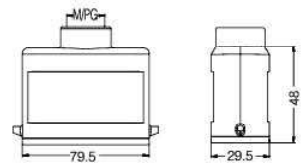

上壳 顶出线 高结构 Hoods, top entry, high construction



螺纹 Thread	型号 Type	订货号 Part Number
M25	UTL-H16A-TEH-2B-M25	19200160446
PG16	UTL-H16A-TEH-2B-PG16	09200160440
PG21	UTL-H16A-TEH-2B-PG21	09200160441

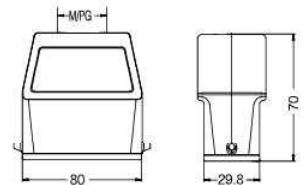

不封底下壳 Housings, bulkhead mounting



螺纹 Thread	型号 Type	订货号 Part Number
---	UTL-H16A-BK-1L	09200160301
---	带塑料盖 With plastic cover	
---	UTL-H16A-BK-1L-CV	09200160321
---	带金属盖 With metal cover	
---	UTL-H16A-BK-1L-MCV	09200160331

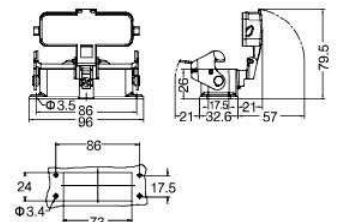

# Metal Hoods & Housings

## 16A 金属外壳

**防护等级 Degree of protection: IP65**

封底下壳 Housings, surface mounting



螺纹 Thread	型号 Type	订货号 Part Number
M20	UTL-H16A-SF-1L-M20	19200161250
2M20	UTL-H16A-SF-1L-2M20	09200160290
M25	UTL-H16A-SF-1L-M25	19200160251
2M25	UTL-H16A-SF-1L-2M25	09200160291
PG16	UTL-H16A-SF-1L-PG16	09200160251
2PG16	UTL-H16A-SF-1L-2PG16	09200160291
PG21	UTL-H16A-SF-1L-PG21	09200160252
带塑料盖 With plastic cover		
M20	UTL-H16A-SF-1L-CV-M20	19200160294
2M20	UTL-H16A-SF-1L-CV-2M20	19200160295
M25	UTL-H16A-SF-1L-CV-M25	19200160296
2M25	UTL-H16A-SF-1L-CV-2M25	19200160297
PG16	UTL-H16A-SF-1L-CV-PG16	09200160221
2PG16	UTL-H16A-SF-1L-CV-2PG16	09200160296
PG21	UTL-H16A-SF-1L-CV-PG21	09200160222
带金属盖 With metal cover		
M20	UTL-H16A-SF-1L-MCV-M20	19200160694
2M20	UTL-H16A-SF-1L-MCV-2M20	19200160695
M25	UTL-H16A-SF-1L-MCV-M25	19200160696
2M25	UTL-H16A-SF-1L-MCV-2M25	19200160697
PG16	UTL-H16A-SF-1L-MCV-PG16	09200160651
2PG16	UTL-H16A-SF-1L-MCV-2PG16	09200160691
PG21	UTL-H16A-SF-1L-MCV-PG21	09200160652

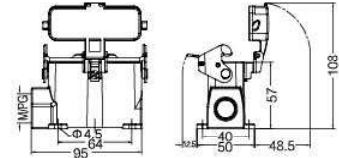

防护盖 Protection covers



接线方式 Connect way	描述 Applications	型号 Type	订货号 Part Number
	金属盖/用于上壳 For hoods	UTL-H16A-MCV-1L.1	09200165423

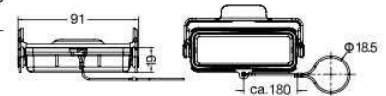

防护盖 Protection covers



接线方式 Connect way	描述 Applications	型号 Type	订货号 Part Number
	金属盖/用于下壳 For housings	UTL-H16A-MCV-2B/1S	09200165424
	金属盖/用于下壳 For housings	UTL-H16A-MCV-2B/2S	09200165425

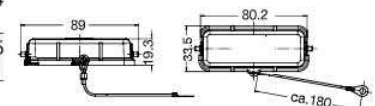

# Metal Hoods & Housings

## 32A 金属外壳

**防护等级 Degree of protection: IP65**

上壳 侧出线 Hoods, side entry



螺纹 Thread	型号 Type	订货号 Part Number
M25	UTL-H32A-SE-4B-M25	19200321521
PG21	UTL-H32A-SE-4B-PG21	09200321520

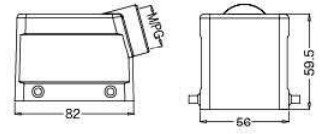

上壳 侧出线 高结构 Hoods, side entry, high construction



螺纹 Thread	型号 Type	订货号 Part Number
M32	UTL-H32A-SEH-4B-M32	19200320527
PG21	UTL-H32A-SEH-4B-PG21	09200320520
PG29	UTL-H32A-SEH-4B-PG29	09200320521

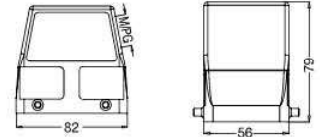

上壳 顶出线 高结构 Hoods, top entry, high construction



螺纹 Thread	型号 Type	订货号 Part Number
M25	UTL-H32A-TEH-4B-M25	19200320426
M32	UTL-H32A-TEH-4B-M32	19200320427
PG21	UTL-H32A-TEH-4B-PG21	09200320420
PG29	UTL-H32A-TEH-4B-PG29	09200320421

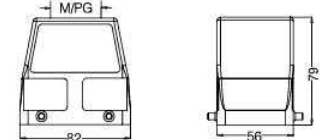

不封底下壳 Housings, bulkhead mounting



螺纹 Thread	型号 Type	订货号 Part Number
---	UTL-H32A-BK-2L	09200320301

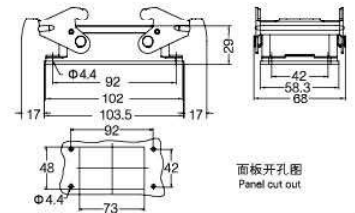

封底下壳 Housings, surface mounting



螺纹 Thread	型号 Type	订货号 Part Number
M25	UTL-H32A-SF-2L-M25	19200320231
M32	UTL-H32A-SF-2L-M32	19200320232
2M32	UTL-H32A-SF-2L-2M32	19200320272
PG21	UTL-H32A-SF-2L-PG21	09200320230
2PG21	UTL-H32A-SF-2L-2PG21	09200320270
PG29	UTL-H32A-SF-2L-PG29	09200320231
2PG29	UTL-H32A-SF-2L-2PG29	09200320271

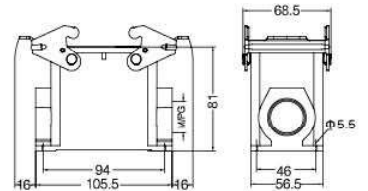

塑料防护盖 4卡扣 Protection covers, plastic cover 4 clamps



接线方式 Connect way	描述 Applications	型号 Type	订货号 Part Number
	用于上壳 For housings	UTL-H32A-CV-4C	09200328001

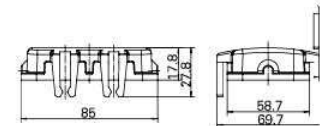

塑料防护盖 Protection covers, plastic cover



接线方式 Connect way	描述 Applications	型号 Type	订货号 Part Number
	用于电缆对接 For housings	UTL-H32A-CV-4B/1	09200328030
	用于下壳 For housings	UTL-H32A-CV-4B/2	09200328031

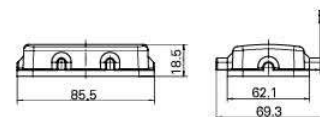

# Metal Hoods & Housings

## 32A 金属外壳

**防护等级 Degree of protection: IP65**

上壳 侧出线 Hoods, side entry



螺纹 Thread	型号 Type	订货号 Part Number
M25	UTL-H32A-SE-2L-M25	19200321531
PG21	UTL-H32A-SE-2L-PG21	09200321530

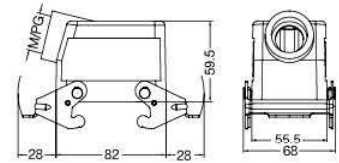

上壳 侧出线 高结构 Hoods, side entry, high construction



螺纹 Thread	型号 Type	订货号 Part Number
M32	UTL-H32A-SEH-2L-M32	19200320537
PG21	UTL-H32A-SEH-2L-PG21	09200320530
PG29	UTL-H32A-SEH-2L-PG29	09200320531

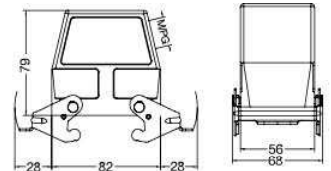

上壳 顶出线 高结构 Hoods, top entry, high construction



螺纹 Thread	型号 Type	订货号 Part Number
M25	UTL-H32A-TEH-2L-M25	19200320447
M32	UTL-H32A-TEH-2L-M32	19200320437
PG21	UTL-H32A-TEH-2L-PG21	09200320430
PG29	UTL-H32A-TEH-2L-PG29	09200320431

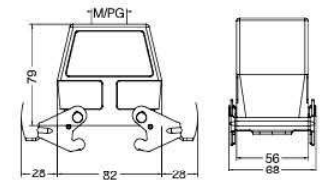

不封底下壳 Housings, bulkhead mounting



螺纹 Thread	型号 Type	订货号 Part Number
---	UTL-H32A-BK-4B 带塑料盖 With plastic cover	09200320202
---	UTL-H32A-BK-4B-CV 带金属盖 With metal cover	09200320302
---	UTL-H32A-BK-4B-MCV	09200320402

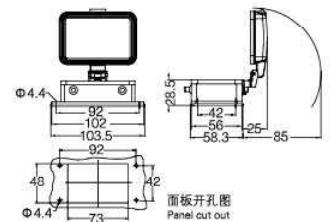

封底下壳 Housings, surface mounting



螺纹 Thread	型号 Type	订货号 Part Number
M25	UTL-H32A-SF-4B-M25	19200320251
M32	UTL-H32A-SF-4B-M32	19200320258
2M32	UTL-H32A-SF-4B-2M32	19200320298
PG21	UTL-H32A-SF-4B-PG21	09200320252
2PG21	UTL-H32A-SF-4B-2PG21	09200320292
PG29	UTL-H32A-SF-4B-PG29	09200320253
2PG29	UTL-H32A-SF-4B-2PG29	09200320293
	带塑料盖 With plastic cover	
M25	UTL-H32A-SF-4B-CV-M25	19200320226
M32	UTL-H32A-SF-4B-CV-M32	19200320227
2M32	UTL-H32A-SF-4B-CV-2M32	19200320267
PG21	UTL-H32A-SF-4B-CV-PG21	09200320220
2PG21	UTL-H32A-SF-4B-CV-2PG21	09200320260
PG29	UTL-H32A-SF-4B-CV-PG29	09200320221
2PG29	UTL-H32A-SF-4B-CV-2PG29	09200320261
	带金属盖 With metal cover	
M25	UTL-H32A-SF-4B-MCV-M25	19200320696
M32	UTL-H32A-SF-4B-MCV-M32	19200320698
2M32	UTL-H32A-SF-4B-MCV-2M32	19200320699
PG21	UTL-H32A-SF-4B-MCV-PG21	09200320652
2PG21	UTL-H32A-SF-4B-MCV-2PG21	09200320692
PG29	UTL-H32A-SF-4B-MCV-PG29	09200320653
2PG29	UTL-H32A-SF-4B-MCV-2PG29	09200320693

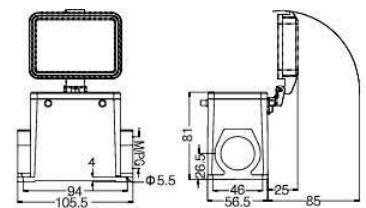

# Plastic Hoods & Housings

## 6B 金属外壳

### 防护等级 Degree of protection: IP65

上壳 侧出线 高结构 Hoods, side entry, high construction



螺纹 Thread	型号 Type	订货号 Part Number
M25	UTL-H6B.P-SEH-4B-M25	19300060110
M32	UTL-H6B.P-SEH-4B-M32	19300060111

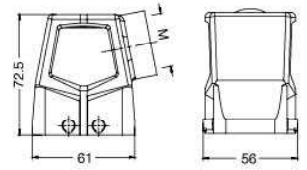

上壳 顶出线 高结构 Hoods, top entry, high construction



螺纹 Thread	型号 Type	订货号 Part Number
M25	UTL-H6B.P-TEH-4B-M25	19300060120
M32	UTL-H6B.P-TEH-4B-M32	19300060121

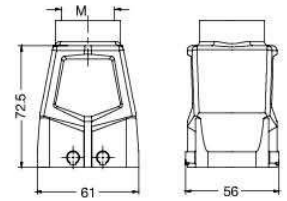

不封底下壳 Housings, bulkhead mounting



螺纹 Thread	型号 Type	订货号 Part Number
---	UTL-H6B.P-BK-2L	09300060300

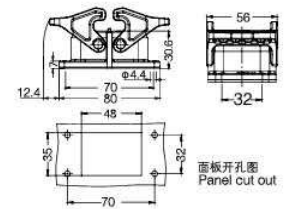

封底下壳 高结构 Housings, surface mounting, high construction



螺纹 Thread	型号 Type	订货号 Part Number
M25	UTL-H6B.P-SFH-2L-M25	19300060131
2M25	UTL-H6B.P-SFH-2L-2M25	19300060135
M32	UTL-H6B.P-SFH-2L-M32	19300060132
2M32	UTL-H6B.P-SFH-2L-2M32	19300060136

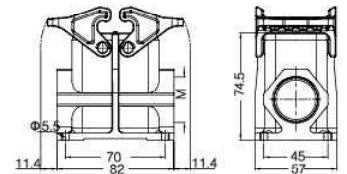

防护盖 Protection covers



螺纹 Thread	型号 Type	订货号 Part Number
---	UTL-H6B.P-CV-4B/2	09300060140

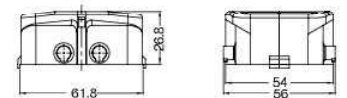

防护盖 Protection covers



螺纹 Thread	型号 Type	订货号 Part Number
---	UTL-H6B.P-CV-2L/1	09300060145

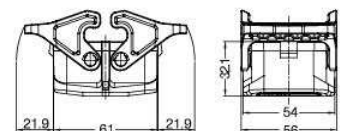

# Metal Hoods & Housings

## 6B 金属外壳

**防护等级 Degree of protection: IP65**

上壳 侧出线 Hoods, side entry



螺纹 Thread	型号 Type	订货号 Part Number
M20	UTL-H6B-SE-2B-M20	19300061540
M25	UTL-H6B-SE-2B-M25	19300061541
PG13.5	UTL-H6B-SE-2B-PG13.5	09300061540
PG16	UTL-H6B-SE-2B-PG16	09300061541

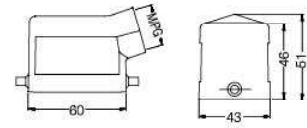

上壳 侧出线 高结构 Hoods, side entry, high construction



螺纹 Thread	型号 Type	订货号 Part Number
M25	UTL-H6B-SEH-2B-M25	19300060546
M32	UTL-H6B-SEH-2B-M32	19300060547
PG21	UTL-H6B-SEH-2B-PG21	09300060542
PG29	UTL-H6B-SEH-2B-PG29	09300060543

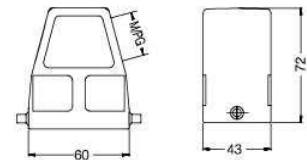

上壳 顶出线 Hoods, top entry



螺纹 Thread	型号 Type	订货号 Part Number
M20	UTL-H6B-TE-2B-M20	19300061440
M25	UTL-H6B-TE-2B-M25	19300061441
PG13.5	UTL-H6B-TE-2B-PG13.5	09300061440
PG16	UTL-H6B-TE-2B-PG16	09300061441

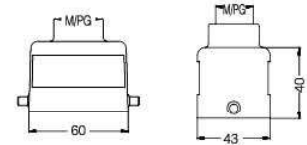

上壳 顶出线 高结构 Hoods, top entry, high construction



螺纹 Thread	型号 Type	订货号 Part Number
M20	UTL-H6B-TEH-2B-M20	19300060445
M25	UTL-H6B-TEH-2B-M25	19300060446
M32	UTL-H6B-TEH-2B-M32	19300060447
PG16	UTL-H6B-TEH-2B-PG16	09300060441
PG21	UTL-H6B-TEH-2B-PG21	09300060442
PG29	UTL-H6B-TEH-2B-PG29	09300060443

我可提供顶部、侧面同时出线的非标品，详见P15-04  
We can provide non-standard products with both top&side entry, see P15-04

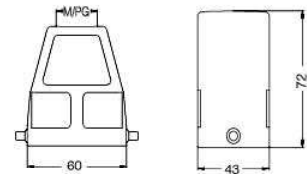

飞线下壳 Housings, cable to cable



螺纹 Thread	型号 Type	订货号 Part Number
M20	UTL-H6B-CCT-1L-M20	19300061750
PG13.5	UTL-H6B-CCT-1L-PG13.5	09300061750
PG16	UTL-H6B-CCT-1L-PG16	09300061751

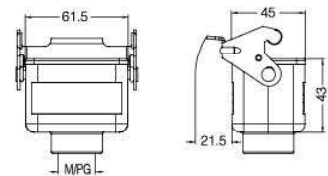

飞线下壳 高结构 Housings, cable to cable, high construction



螺纹 Thread	型号 Type	订货号 Part Number
M25	UTL-H6B-CCTH-1L-M25	19300060756
PG21	UTL-H6B-CCTH-1L-PG21	09300060752
PG29	UTL-H6B-CCTH-1L-PG29	09300060753

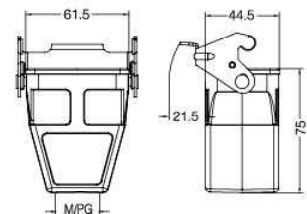

# Plastic Hoods & Housings

## 6B 金属外壳

### 防护等级 Degree of protection: IP65

不封底下壳 Housings, bulkhead mounting



螺纹 Thread	型号 Type	订货号 Part Number
---	UTL-H6B-BK-1L	09300060301
	带塑料盖 With plastic cover	
---	UTL-H6B-BK-1L-CV	09300060302
	带金属料盖 With metal cover	
---	UTL-H6B-BK-1L-MCV	09300060318

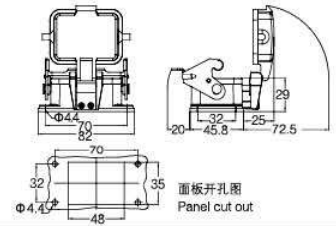

封底下壳 Housings, surface mounting



螺纹 Thread	型号 Type	订货号 Part Number
M20	UTL-H6B-SF-1L-M20	19300061250
2M20	UTL-H6B-SF-1L-2M20	19300061290
M25	UTL-H6B-SF-1L-M25	19300061350
2M25	UTL-H6B-SF-1L-2M25	19300061390
PG16	UTL-H6B-SF-1L-PG16	09300061251
2PG16	UTL-H6B-SF-1L-2PG16	09300061291
	带塑料盖 With plastic cover	
M20	UTL-H6B-SF-1L-CV-M20	19300061255
2M20	UTL-H6B-SF-1L-CV-2M20	19300061295
M25	UTL-H6B-SF-1L-CV-M25	19300061355
2M25	UTL-H6B-SF-1L-CV-2M25	19300061395
PG16	UTL-H6B-SF-1L-CV-PG16	09300061256
2PG16	UTL-H6B-SF-1L-CV-2PG16	09300061296
	带金属盖 With metal cover	
M20	UTL-H6B-SF-1L-MCV-M20	19300062255
2M20	UTL-H6B-SF-1L-MCV-2M20	19300062295
M25	UTL-H6B-SF-1L-MCV-M25	19300062355
2M25	UTL-H6B-SF-1L-MCV-2M25	19300062395
PG16	UTL-H6B-SF-1L-MCV-PG16	09300062256
2PG16	UTL-H6B-SF-1L-MCV-2PG16	09300062296

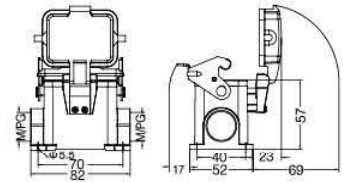

封底下壳 高结构 Housings, surface mounting, high construction



螺纹 Thread	型号 Type	订货号 Part Number
M25	UTL-H6B-SFH-1L-M25	19300060251
2M25	UTL-H6B-SFH-1L-2M25	19300060291
M32	UTL-H6B-SFH-1L-M32	19300060252
2M32	UTL-H6B-SFH-1L-2M32	19300060292
PG21	UTL-H6B-SFH-1L-PG21	09300060252
2PG21	UTL-H6B-SFH-1L-2PG21	09300060292
PG29	UTL-H6B-SFH-1L-PG29	09300060253
2PG29	UTL-H6B-SFH-1L-2PG29	09300060293
	带塑料盖 With plastic cover	
M25	UTL-H6B-SFH-1L-CV-M25	19300060256
2M25	UTL-H6B-SFH-1L-CV-2M25	19300060296
M32	UTL-H6B-SFH-1L-CV-M32	19300060257
2M32	UTL-H6B-SFH-1L-CV-2M32	19300060297
PG21	UTL-H6B-SFH-1L-CV-PG21	09300060257
2PG21	UTL-H6B-SFH-1L-CV-2PG21	09300060297
PG29	UTL-H6B-SFH-1L-CV-PG29	09300060258
2PG29	UTL-H6B-SFH-1L-CV-2PG29	09300060298
	带金属盖 With metal cover	
M25	UTL-H6B-SFH-1L-MCV-M25	19300067256
2M25	UTL-H6B-SFH-1L-MCV-2M25	19300067296
M32	UTL-H6B-SFH-1L-MCV-M32	19300061257
2M32	UTL-H6B-SFH-1L-MCV-2M32	19300061297
PG21	UTL-H6B-SFH-1L-MCV-PG21	09300062257
2PG21	UTL-H6B-SFH-1L-MCV-2PG21	09300062297
PG29	UTL-H6B-SFH-1L-MCV-PG29	09300062258
2PG29	UTL-H6B-SFH-1L-MCV-2PG29	09300062298

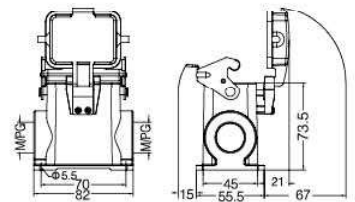

# Metal Hoods & Housings

## 6B 金属外壳

**防护等级** Degree of protection: IP65

防护盖 Protection covers, plastic



接线方式 Connect way	描述 Applications	型号 Type	订货号 Part Number
---	塑料盖 For hoods	UTL-H6B-CV-2C	09300065420

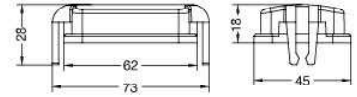

防护盖 Protection covers, metal



接线方式 Connect way	描述 Applications	型号 Type	订货号 Part Number
	金属盖/用于上壳 For hoods	UTL-H6B-MCV-2B/1	09300065427
	金属盖/用于下壳 For housings	UTL-H6B-MCV-2B/2	09300065425

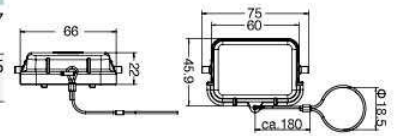

防护盖 Protection covers, metal



接线方式 Connect way	描述 Applications	型号 Type	订货号 Part Number
	金属盖/用于上壳 For hoods	UTL-H6B-MCV-1L.1S	09300065423

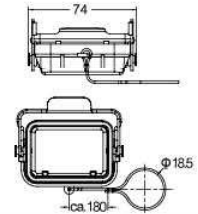

上壳侧出线/顶出线 高结构 Hoods, side&top entry, high construction



型号为:UTL-H6B-SEH/TEH-2B-XX/XX  
如有需要请与我司联系



# Metal Hoods & Housings For higher environmental requirements

## 6B 金属外壳适用于苛刻环境 (耐腐蚀)

**防护等级 Degree of protection: IP65**

上壳 侧出线 Hoods, side entry



螺纹 Thread	型号 Type	订货号 Part Number
M20	UTL-H6B-MSE-2B-M20	19370061540
PG13.5	UTL-H6B-MSE-2B-PG13.5	09370061540

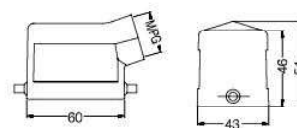

上壳 侧出线 高结构 Hoods, side entry, high construction



螺纹 Thread	型号 Type	订货号 Part Number
M25	UTL-H6B-MSEH-2B-M25	19370060546
PG21	UTL-H6B-MSEH-2B-PG21	09370060542

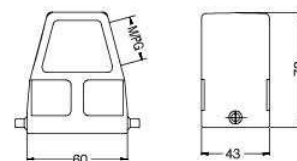

上壳 顶出线 Hoods, top entry



螺纹 Thread	型号 Type	订货号 Part Number
M20	UTL-H6B-MTE-2B-M20	19370061440
PG13.5	UTL-H6B-MTE-2B-PG13.5	09370061440
PG16	UTL-H6B-MTE-2B-PG16	09370061441

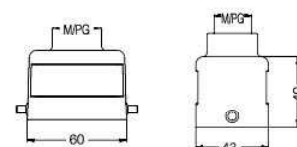

上壳 顶出线 高结构 Hoods, top entry, high construction



螺纹 Thread	型号 Type	订货号 Part Number
M25	UTL-H6B-MTEH-2B-M25	19370060446

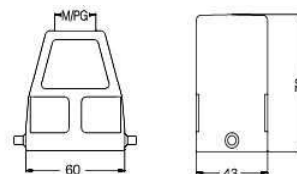

飞线下壳 Housings, cable to cable



螺纹 Thread	型号 Type	订货号 Part Number
PG13.5	UTL-H6B-MCCT-1L-PG13.5	09370061750

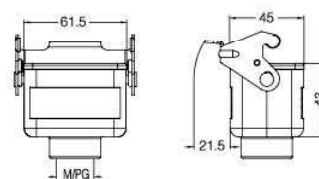

# Metal Hoods & Housings For higher environmental requirements

## 6B 金属外壳适用于苛刻环境 (耐腐蚀)

**防护等级 Degree of protection: IP65**

上壳 侧出线 Hoods, side entry



螺纹 Thread	型号 Type	订货号 Part Number
---	UTL-H6B-MBK-1L	09370060301
	带金属盖 With metal cover	
---	UTL-H6B-MBK-1L-MMCV	09370060318

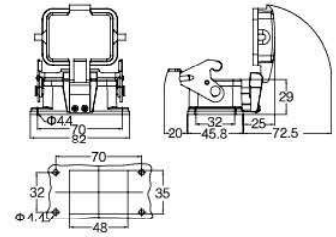

封底下壳 Housings, surface mounting



螺纹 Thread	型号 Type	订货号 Part Number
2PG16	UTL-H6B-MSF-1L-2PG16	09370061291
2M20	UTL-H6B-MSF-1L-2M20	19370061290

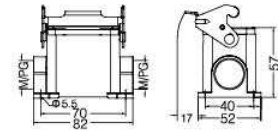

防护盖 Protection covers



螺纹 Thread	型号 Type	订货号 Part Number
M25	UTL-H6B-MMCV-2B/1	09370065407
	UTL-H6B-MMCV-2B/2	09370065405

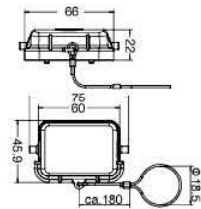

# Hoods & Housings for harsh environmental requirements

## 6B 高防护外壳

防护等级 Degree of protection: IP65

W version

上壳 侧出线 高结构 Hoods, side entry, high construction



螺纹 Thread	型号 Type	订货号 Part Number
M20	UTL-HP6B-SEH-2S-M20	19400060210
M25	UTL-HP6B-SEH-2S-M25	19400060211
M32	UTL-HP6B-SEH-2S-M32	19400060212
PG16	UTL-HP6B-SEH-2S-PG16	09400060211
PG21	UTL-HP6B-SEH-2S-PG21	09400060212

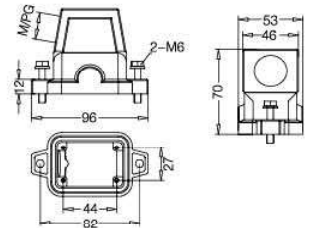

上壳 顶出线 高结构 Hoods, top entry, high construction



螺纹 Thread	型号 Type	订货号 Part Number
M20	UTL-HP6B-TEH-2S-M20	19400060220
M25	UTL-HP6B-TEH-2S-M25	19400060221
M32	UTL-HP6B-TEH-2S-M32	19400060222
PG16	UTL-HP6B-TEH-2S-PG16	09400060221
PG21	UTL-HP6B-TEH-2S-PG21	09400060222
PG29	UTL-HP6B-TEH-2S-PG29	09400060223

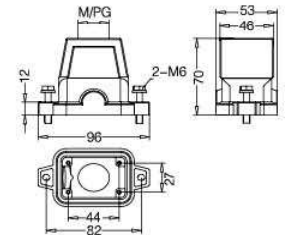

封底下壳 高结构 Housings, surface mounting, high construction



螺纹 Thread	型号 Type	订货号 Part Number
M20	UTL-HP6B-SFH-2H-M20	19400060230
M25	UTL-HP6B-SFH-2H-M25	19400060231
M32	UTL-HP6B-SFH-2H-M32	19400060232
PG16	UTL-HP6B-SFH-2H-PG16	09400060231
PG21	UTL-HP6B-SFH-2H-PG21	09400060232

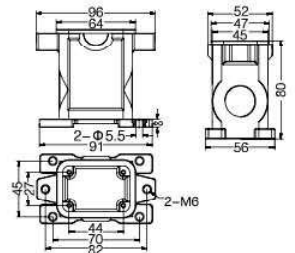

不封底下壳 Housings, bulkhead mounting



螺纹 Thread	型号 Type	订货号 Part Number
---	UTL-HP6B-BK-2H	09400060201

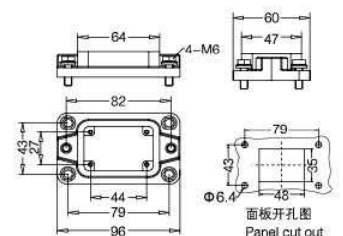

# Hoods & Housings for harsh environmental requirements

## 6B 高防护外壳

防护等级 Degree of protection: IP65

H version

上壳 侧出线 高结构 Hoods, side entry, high construction



螺纹 Thread	型号 Type	订货号 Part Number
螺栓联锁 Screw locking		
M20	UTL-HP6B/H-SEH-2S-M20	19400060510
M25	UTL-HP6B/H-SEH-2S-M25	19400060511
M32	UTL-HP6B/H-SEH-2S-M32	19400060512
PG16	UTL-HP6B/H-SEH-2S-PG16	09400060511
PG21	UTL-HP6B/H-SEH-2S-PG21	09400060512
PG29	UTL-HP6B/H-SEH-2S-PG29	09400060513
轴销联锁 Toggle locking		
M20	UTL-HP6B/H-SEH-2T-M20	19400060500
M25	UTL-HP6B/H-SEH-2T-M25	19400060501
M32	UTL-HP6B/H-SEH-2T-M32	19400060502
PG16	UTL-HP6B/H-SEH-2T-PG16	09400060501
PG21	UTL-HP6B/H-SEH-2T-PG21	09400060502

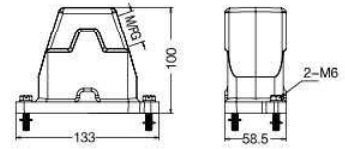

上壳 顶出线 高结构 Hoods, top entry, high construction



螺纹 Thread	型号 Type	订货号 Part Number
螺栓联锁 Screw locking		
M20	UTL-HP6B/H-TEH-2S-M20	19400060410
M25	UTL-HP6B/H-TEH-2S-M25	19400060411
M32	UTL-HP6B/H-TEH-2S-M32	19400060412
PG16	UTL-HP6B/H-TEH-2S-PG16	09400060411
PG21	UTL-HP6B/H-TEH-2S-PG21	09400060412
PG29	UTL-HP6B/H-TEH-2S-PG29	09400060413
轴销联锁 Toggle locking		
M20	UTL-HP6B/H-TEH-2T-M20	19400060400
M25	UTL-HP6B/H-TEH-2T-M25	19400060401
M32	UTL-HP6B/H-TEH-2T-M32	19400060402
PG16	UTL-HP6B/H-TEH-2T-PG16	09400060401
PG21	UTL-HP6B/H-TEH-2T-PG21	09400060402
PG29	UTL-HP6B/H-TEH-2T-PG29	09400060403

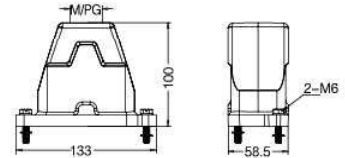

封底下壳 高结构 Housings, surface mounting, high construction



螺纹 Thread	型号 Type	订货号 Part Number
螺栓联锁 Screw locking		
M20	UTL-HP6B/H-SFH-2H-M20	19400061260
M25	UTL-HP6B/H-SFH-2H-M25	19400061261
M32	UTL-HP6B/H-SFH-2H-M32	19400061262
PG16	UTL-HP6B/H-SFH-2H-PG16	09400061260
PG21	UTL-HP6B/H-SFH-2H-PG21	09400061261
PG29	UTL-HP6B/H-SFH-2H-PG29	09400061262
轴销联锁 Toggle locking		
M20	UTL-HP6B/H-SFH-2T-M20	19400061270
M25	UTL-HP6B/H-SFH-2T-M25	19400061271
M32	UTL-HP6B/H-SFH-2T-M32	19400061272
PG16	UTL-HP6B/H-SFH-2T-PG16	09400061270
PG21	UTL-HP6B/H-SFH-2T-PG21	09400061271
PG29	UTL-HP6B/H-SFH-2T-PG29	09400061272

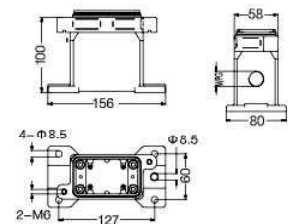

# Hoods & Housings for harsh environmental requirements

## 6B 高防护外壳

### 防护等级 Degree of protection: IP65

### H version

不封底下壳 Housings, bulkhead mounting



螺纹 Thread	型号 Type	订货号 Part Number
---	螺栓联锁 Screw locking	
---	UTL-HP6B/H-BK-2H	09400060311
---	轴销联锁 Toggle locking	
---	UTL-HP6B/H-BK-2T	09400060301
---	带金属盖 With metal cover	
---	螺栓联锁 Screw locking	
---	UTL-HP6B/H-BK-2H-MCV	09400060317
---	轴销联锁 Toggle locking	
---	UTL-HP6B/H-BK-2T-MCV	09400060307

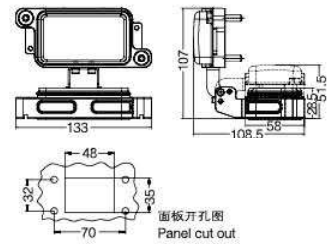

防护盖 Protection covers



螺纹 Thread	型号 Type	订货号 Part Number
---	螺栓联锁 Screw locking	
---	UTL-HP6B/H-MCV-2S	09400065411
---	轴销联锁 Toggle locking	
---	UTL-HP6B/H-MCV-2T	09400065401

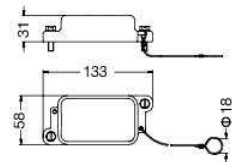

上壳 侧出线 高结构 Hoods, side entry, high construction



螺纹 Thread	型号 Type	订货号 Part Number
M20	UTL-HP6B/H-SEH-4S-M20	19400061360
M25	UTL-HP6B/H-SEH-4S-M25	19400061361
M32	UTL-HP6B/H-SEH-4S-M32	19400061362
M40	UTL-HP6B/H-SEH-4S-M40	19400061363
PG16	UTL-HP6B/H-SEH-4S-PG16	09400061361
PG21	UTL-HP6B/H-SEH-4S-PG21	09400061362

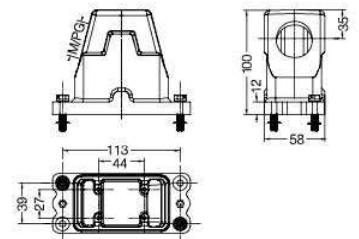

上壳 顶出线 高结构 Hoods, top entry, high construction



螺纹 Thread	型号 Type	订货号 Part Number
M20	UTL-HP6B/H-TEH-4S-M20	19400061460
M25	UTL-HP6B/H-TEH-4S-M25	19400061461
M32	UTL-HP6B/H-TEH-4S-M32	19400061462
M40	UTL-HP6B/H-TEH-4S-M40	19400061463
PG16	UTL-HP6B/H-TEH-4S-PG16	09400061461
PG21	UTL-HP6B/H-TEH-4S-PG21	09400061462
PG29	UTL-HP6B/H-TEH-4S-PG29	09400061463

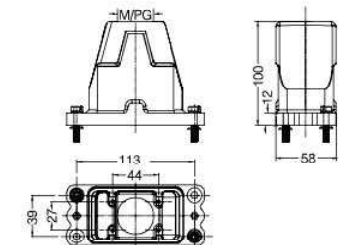

不封底下壳 Housings, bulkhead mounting



螺纹 Thread	型号 Type	订货号 Part Number
---	UTL-HP6B/H-BK-4H	09400060202

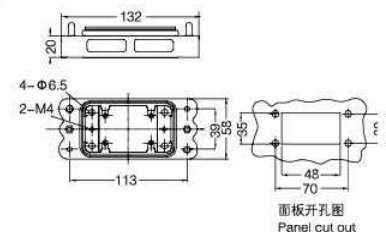

# Hoods & Housings for harsh environmental requirements

## 6B 高防护外壳

### 防护等级 Degree of protection: IP65

上壳 侧出线 高结构 Hoods, side entry, high construction



螺纹 Thread	型号 Type	订货号 Part Number
M20	UTL-HC6B-SEH-2S-M20	19400061500
M25	UTL-HC6B-SEH-2S-M25	19400061501
PG16	UTL-HC6B-SEH-2S-PG16	09400061500
PG21	UTL-HC6B-SEH-2S-PG21	09400061501

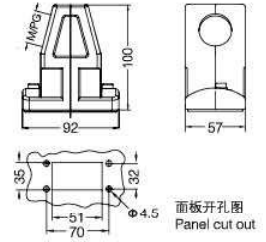

上壳 顶出线 高结构 Hoods, top entry, high construction



螺纹 Thread	型号 Type	订货号 Part Number
M20	UTL-HC6B-TEH-2S-M20	19400061550
M25	UTL-HC6B-TEH-2S-M25	19400061551
PG16	UTL-HC6B-TEH-2S-PG16	09400061550
PG21	UTL-HC6B-TEH-2S-PG21	09400061551

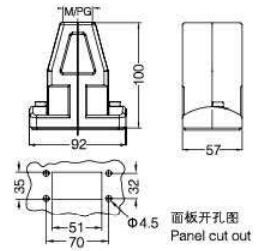

芯体安装支块 Protection covers



描述 Application	型号 Type	订货号 Part Number
整体型外壳适配 For integral type hoods	UTL-APT-C	09400061600

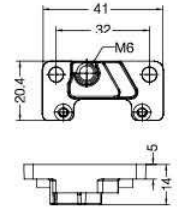

# Plastic Hoods & Housings

## 10B 塑料外壳

### 防护等级 Degree of protection: IP65

上壳 侧出线 高结构 Hoods, side entry, high construction



螺纹 Thread	型号 Type	订货号 Part Number
M25	UTL-H10B.P-SEH-4B-M25	19300100110
M32	UTL-H10B.P-SEH-4B-M32	19300100111

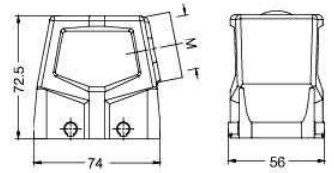

上壳 顶出线 高结构 Hoods, top entry, high construction



螺纹 Thread	型号 Type	订货号 Part Number
M25	UTL-H10B.P-TEH-4B-M25	19300100120
M32	UTL-H10B.P-TEH-4B-M32	19300100121

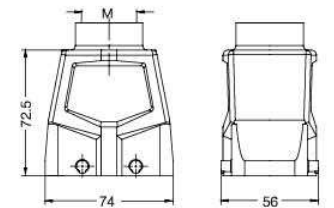

不封底下壳 Housings, bulkhead mounting



螺纹 Thread	型号 Type	订货号 Part Number
---	UTL-H10B.P-BK-2L	09300100300

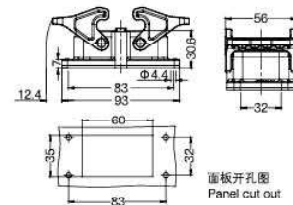

封底下壳 高结构 Housings, surface mounting, high construction



螺纹 Thread	型号 Type	订货号 Part Number
M25	UTL-H10B.P-SFH-2L-M25	19300100131
2M25	UTL-H10B.P-SFH-2L-2M25	19300100135
M32	UTL-H10B.P-SFH-2L-M32	19300100132
2M32	UTL-H10B.P-SFH-2L-2M32	19300100136

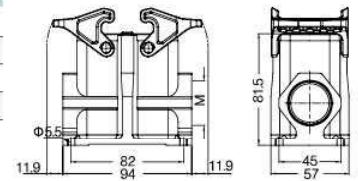

防护盖 Protection covers



螺纹 Thread	型号 Type	订货号 Part Number
---	UTL-H10B.P-CV-4B/2	09300100140

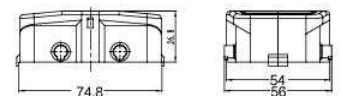

防护盖 Protection covers



螺纹 Thread	型号 Type	订货号 Part Number
---	UTL-H10B.P-CV-2L/1	09300100145

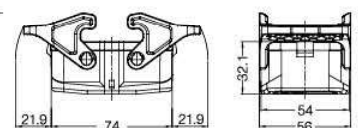

# Metal Hoods & Housings

## 10B 金属外壳

**防护等级 Degree of protection: IP65**

上壳 侧出线 Hoods, side entry



螺纹 Thread	型号 Type	订货号 Part Number
M20	UTL-H10B-SE-2B-M20	19300101540
M25	UTL-H10B-SE-2B-M25	19300101541
PG16	UTL-H10B-SE-2B-PG16	09300101541

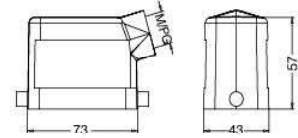

上壳 侧出线 高结构 Hoods, side entry, high construction



螺纹 Thread	型号 Type	订货号 Part Number
M25	UTL-H10B-SEH-2B-M25	19300100546
M32	UTL-H10B-SEH-2B-M32	19300100547
PG21	UTL-H10B-SEH-2B-PG21	09300100542
PG29	UTL-H10B-SEH-2B-PG29	09300100543

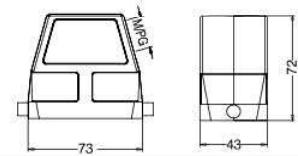

上壳 顶出线 Hoods, top entry



螺纹 Thread	型号 Type	订货号 Part Number
M20	UTL-H10B-TE-2B-M20	19300101440
M25	UTL-H10B-TE-2B-M25	19300101441
PG16	UTL-H10B-TE-2B-PG16	09300101441

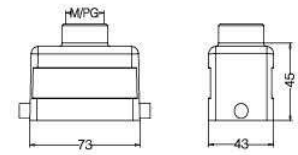

上壳 顶出线 高结构 Hoods, top entry, high construction



螺纹 Thread	型号 Type	订货号 Part Number
M25	UTL-H10B-TEH-2B-M25	19300100446
M32	UTL-H10B-TEH-2B-M32	19300100447
PG21	UTL-H10B-TEH-2B-PG21	09300100442
PG29	UTL-H10B-TEH-2B-PG29	09300100443

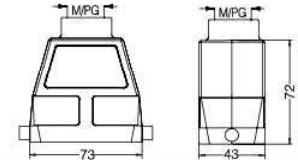

飞线下壳 Housings, cable to cable



螺纹 Thread	型号 Type	订货号 Part Number
M20	UTL-H10B-CCT-1L-M20	19300101750
PG16	UTL-H10B-CCT-1L-PG16	09300101751

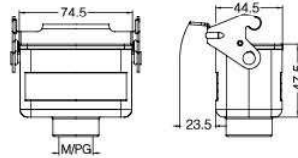

飞线下壳 高结构 Housings, cable to cable, high construction



螺纹 Thread	型号 Type	订货号 Part Number
M25	UTL-H10B-CCTH-1L-M25	19300100756
M32	UTL-H10B-CCTH-1L-M32	19300100757
PG21	UTL-H10B-CCTH-1L-PG21	09300100752
PG29	UTL-H10B-CCTH-1L-PG29	09300100753

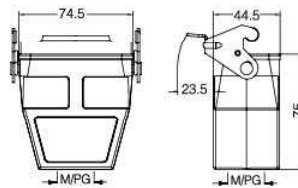

不封底下壳 Housings, bulkhead mounting



螺纹 Thread	型号 Type	订货号 Part Number
---	UTL-H10B-BK-SE-1L(82-68-4.5)	09300100901
---	UTL-H10B-BK-SE-1L(82-70-4.5)	09300100961
---	UTL-H10B-BK-SE-1L(85-73-4.5)	09304100921
---	UTL-H10B-BK-SE-1L(85-73-5.5)	09304100971
---	UTL-H10B-BK-SE-1L(92-70-4.1)	09628100974
---	UTL-H10B-BK-SE-1L(92-70-4.3)	09304100974
---	UTL-H10B-BK-SE-1L(92-77-4.3)	09304100970
---	UTL-H10B-BK-SE-1L(92-80-5.1)	09304100983
---	UTL-H10B-BK-SE-1L(98-70-4.3)	09304100960
---	UTL-H10B-BK-SE-1L(98-68-4.5)	09304100909

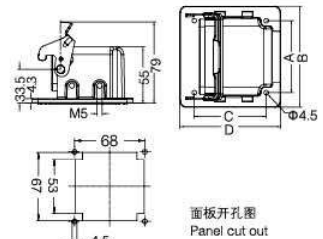



# Metal Hoods & Housings

## 10B 金属外壳

### 防护等级 Degree of protection: IP65

不封底下壳 Housings, bulkhead mounting



螺纹 Thread	型号 Type	订货号 Part Number
---	UTL-H10B-BK-1L	09300100305
	带塑料盖 With plastic cover	
---	UTL-H10B-BK-1L-CV	09300100303
	带金属料盖 With metal cover	
---	UTL-H10B-BK-1L-MCV	09300100318

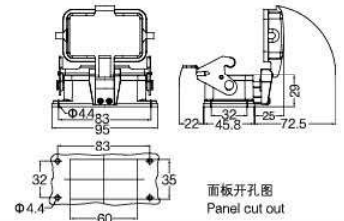

封底下壳 Housings, surface mounting



螺纹 Thread	型号 Type	订货号 Part Number
M20	UTL-H10B-SF-1L-M20	19300101250
2M20	UTL-H10B-SF-1L-2M20	19300101290
M25	UTL-H10B-SF-1L-M25	19300101251
2M25	UTL-H10B-SF-1L-2M25	19300101291
PG16	UTL-H10B-SF-1L-PG16	09300101251
2PG16	UTL-H10B-SF-1L-2PG16	09300101291
	带塑料盖 With plastic cover	
M20	UTL-H10B-SF-1L-CV-M20	19300101255
2M20	UTL-H10B-SF-1L-CV-2M20	19300101295
M25	UTL-H10B-SF-1L-CV-M25	19300101256
2M25	UTL-H10B-SF-1L-CV-2M25	19300101296
PG16	UTL-H10B-SF-1L-CV-PG16	09300101256
2PG16	UTL-H10B-SF-1L-CV-2PG16	09300101296
	带金属盖 With metal cover	
M20	UTL-H10B-SF-1L-MCV-M20	19300102255
2M20	UTL-H10B-SF-1L-MCV-2M20	19300102295
M25	UTL-H10B-SF-1L-MCV-M25	19300102256
2M25	UTL-H10B-SF-1L-MCV-2M25	19300102296
PG16	UTL-H10B-SF-1L-MCV-PG16	09300102256
2PG16	UTL-H10B-SF-1L-MCV-2PG16	09300102296

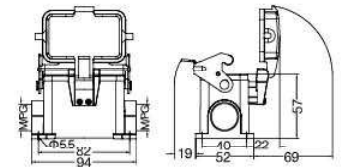

封底下壳 高结构 Housings, surface mounting, high construction



螺纹 Thread	型号 Type	订货号 Part Number
M25	UTL-H10B-SFH-1L-M25	19300100291
2M25	UTL-H10B-SFH-1L-2M25	19300100391
M32	UTL-H10B-SFH-1L-M32	19300100292
2M32	UTL-H10B-SFH-1L-2M32	19300100392
PG21	UTL-H10B-SFH-1L-PG21	09300100192
2PG21	UTL-H10B-SFH-1L-2PG21	09300100292
PG29	UTL-H10B-SFH-1L-PG29	09300100193
2PG29	UTL-H10B-SFH-1L-2PG29	09300100293
	带塑料盖 With plastic cover	
M25	UTL-H10B-SFH-1L-CV-M25	19300100196
2M25	UTL-H10B-SFH-1L-CV-2M25	19300100296
M32	UTL-H10B-SFH-1L-CV-M32	19300100197
2M32	UTL-H10B-SFH-1L-CV-2M32	19300100297
PG21	UTL-H10B-SFH-1L-CV-PG21	09300100197
2PG21	UTL-H10B-SFH-1L-CV-2PG21	09300100297
PG29	UTL-H10B-SFH-1L-CV-PG29	09300100198
2PG29	UTL-H10B-SFH-1L-CV-2PG29	09300100298
	带金属盖 With metal cover	
M25	UTL-H10B-SFH-1L-MCV-M25	19300107295
2M25	UTL-H10B-SFH-1L-MCV-2M25	19300107296
M32	UTL-H10B-SFH-1L-MCV-M32	19300107297
2M32	UTL-H10B-SFH-1L-MCV-2M32	19300107298
PG21	UTL-H10B-SFH-1L-MCV-PG21	09300102197
2PG21	UTL-H10B-SFH-1L-MCV-2PG21	09300102297
PG29	UTL-H10B-SFH-1L-MCV-PG29	09300102198
2PG29	UTL-H10B-SFH-1L-MCV-2PG29	09300102298

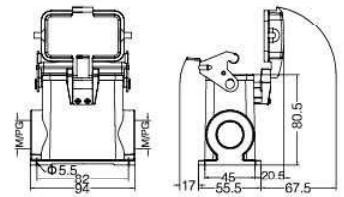

# Metal Hoods & Housings

## 10B 金属外壳

### 防护等级 Degree of protection: IP65

上壳 侧出线 Hoods, side entry



螺纹 Thread	型号 Type	订货号 Part Number
M20	UTL-H10B-SE-4B-M20	19300101520
M25	UTL-H10B-SE-4B-M25	19300101521
PG16	UTL-H10B-SE-4B-PG16	09300101521

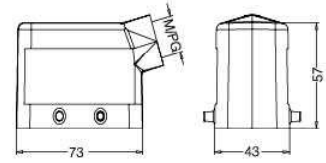

上壳 侧出线 高结构 Hoods, side entry, high construction



螺纹 Thread	型号 Type	订货号 Part Number
M25	UTL-H10B-SEH-4B-M25	19300100526
M32	UTL-H10B-SEH-4B-M32	19300100527
PG21	UTL-H10B-SEH-4B-PG21	09300100522
PG29	UTL-H10B-SEH-4B-PG29	09300100523

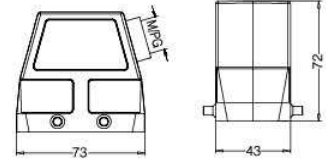

我司可提供顶部、侧面同时出线的非标品, 详见P16-06  
We can provide non-standard products with both top&side entry, see P16-06

上壳 顶出线 Hoods, top entry



螺纹 Thread	型号 Type	订货号 Part Number
M20	UTL-H10B-TE-4B-M20	19300101420
M25	UTL-H10B-TE-4B-M25	19300101421
PG16	UTL-H10B-TE-4B-PG16	09300101421

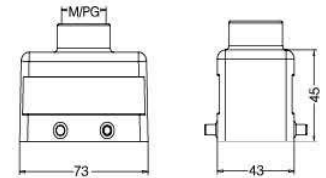

上壳 顶出线 高结构 Hoods, top entry, high construction



螺纹 Thread	型号 Type	订货号 Part Number
M25	UTL-H10B-TEH-4B-M25	19300100426
M32	UTL-H10B-TEH-4B-M32	19300100427
2M20	UTL-H10B-TEH-4B-2M20	19300100465
PG16	UTL-H10B-TEH-4B-PG16	09300100421
PG21	UTL-H10B-TEH-4B-PG21	09300100422
PG29	UTL-H10B-TEH-4B-PG29	09300100423

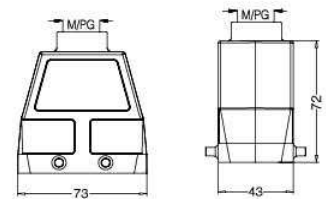

不封底下壳 Housings, bulkhead mounting



螺纹 Thread	型号 Type	订货号 Part Number
---	UTL-H10B-BK-2L	09300100301

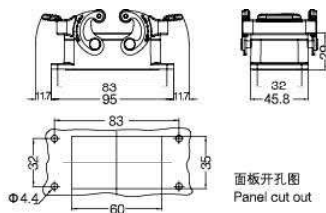

封底下壳 Housings, surface mounting



螺纹 Thread	型号 Type	订货号 Part Number
M20	UTL-H10B-SF-2L-M20	19300101230
2M20	UTL-H10B-SF-2L-2M20	19300101270
M25	UTL-H10B-SF-2L-M25	19300101231
2M25	UTL-H10B-SF-2L-2M25	19300101271
PG16	UTL-H10B-SF-2L-PG16	09300101231
2PG16	UTL-H10B-SF-2L-2PG16	09300101271

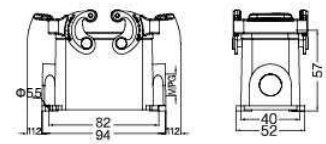

# Metal Hoods & Housings

## 10B 金属外壳

### 防护等级 Degree of protection: IP65

封底下壳 高结构 Housings, surface mounting, high construction



螺纹 Thread	型号 Type	订货号 Part Number
M25	UTL-H10B-SFH-2L-M25	19300100231
2M25	UTL-H10B-SFH-2L-2M25	19300100271
M32	UTL-H10B-SFH-2L-M32	19300100232
2M32	UTL-H10B-SFH-2L-2M32	19300100272
PG21	UTL-H10B-SFH-2L-PG21	09300100232
2PG21	UTL-H10B-SFH-2L-2PG21	09300100272
PG29	UTL-H10B-SFH-2L-PG29	09300100233
2PG29	UTL-H10B-SFH-2L-2PG29	09300100273

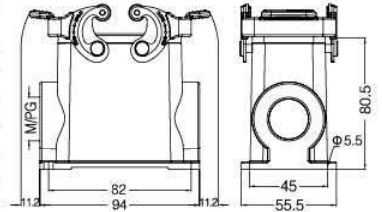

飞线下壳 Housings, cable to cable



螺纹 Thread	型号 Type	订货号 Part Number
M20	UTL-H10B-CCT-2L-M20	19300101730
PG16	UTL-H10B-CCT-2L-PG16	09300101731

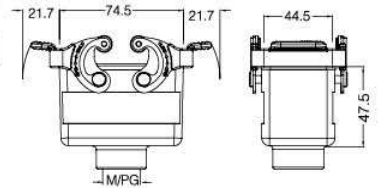

飞线下壳 高结构 Housings, cable to cable, high construction



螺纹 Thread	型号 Type	订货号 Part Number
M25	UTL-H10B-CCTH-2L-M25	19300100736
M32	UTL-H10B-CCTH-2L-M32	19300100737
PG21	UTL-H10B-CCTH-2L-PG21	09300100732
PG29	UTL-H10B-CCTH-2L-PG29	09300100733

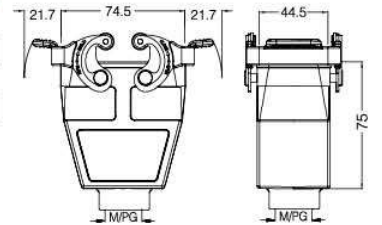

塑料防护盖 Protection covers, plastic



接线方式 Connect way	描述 Applications	型号 Type	订货号 Part Number
---	用于上壳 For hoods	UTL-H10B-CV-4C	09300105401

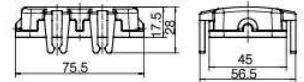

塑料防护盖 Protection covers, Plastic



接线方式 Connect way	描述 Applications	型号 Type	订货号 Part Number
	塑料盖/用于飞线下壳 For Housings, cable to cable	UTL-H10B-CV-4B/1	09300105426
	塑料盖/用于不封底,封底下壳 For housing, bulkhead/ surface mounting	UTL-H10B-CV-4B/2	09300105428

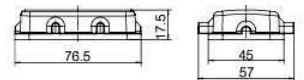

# Metal Hoods & Housings

## 10B 金属外壳

### 防护等级 Degree of protection: IP65

上壳 侧出线 Hoods, side entry



螺纹 Thread	型号 Type	订货号 Part Number
M20	UTL-H10B-SE-2L-M20	19300101530
PG16	UTL-H10B-SE-2L-PG16	09300101531

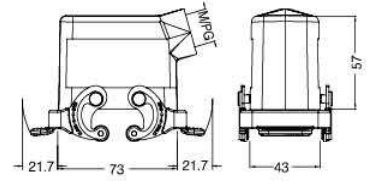

上壳 侧出线 高结构 Hoods, side entry, high construction



螺纹 Thread	型号 Type	订货号 Part Number
M25	UTL-H10B-SEH-2L-M25	19300100536
M32	UTL-H10B-SEH-2L-M32	19300100537
PG21	UTL-H10B-SEH-2L-PG21	09300100532
PG29	UTL-H10B-SEH-2L-PG29	09300100533

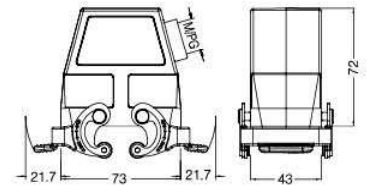

上壳 顶出线 Hoods, top entry



螺纹 Thread	型号 Type	订货号 Part Number
M20	UTL-H10B-TE-2L-M20	19300101430
PG16	UTL-H10B-TE-2L-PG16	09300101431

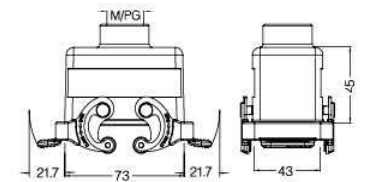

上壳 顶出线 高结构 Hoods, top entry, high construction



螺纹 Thread	型号 Type	订货号 Part Number
M25	UTL-H10B-TEH-2L-M25	19300100436
M32	UTL-H10B-TEH-2L-M32	19300100437
PG21	UTL-H10B-TEH-2L-PG21	09300100432
PG29	UTL-H10B-TEH-2L-PG29	09300100433

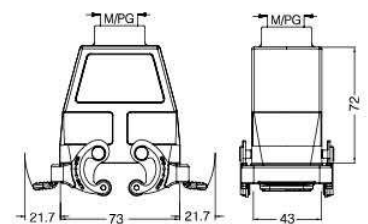

不封底下壳 Housings, bulkhead mounting



螺纹 Thread	型号 Type	订货号 Part Number
---	UTL-H10B-BK-4B 带塑料盖 With plastic cover	09300100300
---	UTL-H10B-BK-4B-CV 带金属盖 With metal cover	09300100302
---	UTL-H10B-BK-4B-MCV	09300100317

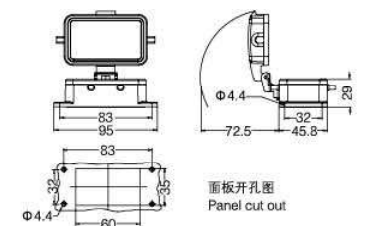

上壳侧出线/顶出线 高结构 Hoods, side&top entry, high construction



型号为:UTL-H10B-SEH/TEH-4B-XX/XX  
如有需要请与我司联系

# Metal Hoods & Housings

## 10B 金属外壳

### 防护等级 Degree of protection: IP65

封底下壳 Housings, surface mounting



螺纹 Thread	型号 Type	订货号 Part Number
M20	UTL-H10B-SF-4B-M20	19300101125
2M20	UTL-H10B-SF-4B-2M20	19300101165
M25	UTL-H10B-SF-4B-M25	19300101126
2M25	UTL-H10B-SF-4B-2M25	19300101166
PG16	UTL-H10B-SF-4B-PG16	09300101121
2PG16	UTL-H10B-SF-4B-2PG16	09300101161
带塑料盖 With plastic cover		
M20	UTL-H10B-SF-4B-CV-M20	19300101225
2M20	UTL-H10B-SF-4B-CV-2M20	19300101265
M25	UTL-H10B-SF-4B-CV-M25	19300101226
2M25	UTL-H10B-SF-4B-CV-2M25	19300101266
PG16	UTL-H10B-SF-4B-CV-PG16	09300101221
2PG16	UTL-H10B-SF-4B-CV-2PG16	09300101261
带金属盖 With metal cover		
M20	UTL-H10B-SF-4B-MCV-M20	19300102225
2M20	UTL-H10B-SF-4B-MCV-2M20	19300102265
M25	UTL-H10B-SF-4B-MCV-M25	19300102226
2M25	UTL-H10B-SF-4B-MCV-2M25	19300102266
PG16	UTL-H10B-SF-4B-MCV-PG16	09300102221
2PG16	UTL-H10B-SF-4B-MCV-2PG16	09300102261

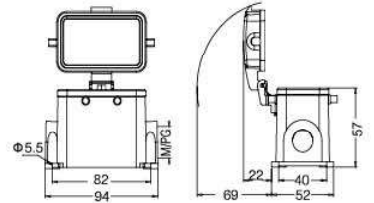

封底下壳 高结构 Housings, surface mounting, high construction



螺纹 Thread	型号 Type	订货号 Part Number
M25	UTL-H10B-SFH-4B-M25	19300100126
2M25	UTL-H10B-SFH-4B-2M25	19300100166
M32	UTL-H10B-SFH-4B-M32	19300100127
2M32	UTL-H10B-SFH-4B-2M32	19300100167
PG21	UTL-H10B-SFH-4B-PG21	09300100122
2PG21	UTL-H10B-SFH-4B-2PG21	09300100162
PG29	UTL-H10B-SFH-4B-PG29	09300100123
2PG29	UTL-H10B-SFH-4B-2PG29	09300100163
带塑料盖 With plastic cover		
M25	UTL-H10B-SFH-4B-CV-M25	19300100226
2M25	UTL-H10B-SFH-4B-CV-2M25	19300100266
M32	UTL-H10B-SFH-4B-CV-M32	19300100227
2M32	UTL-H10B-SFH-4B-CV-2M32	19300100267
PG21	UTL-H10B-SFH-4B-CV-PG21	09300100222
2PG21	UTL-H10B-SFH-4B-CV-2PG21	09300100262
PG29	UTL-H10B-SFH-4B-CV-PG29	09300100223
2PG29	UTL-H10B-SFH-4B-CV-2PG29	09300100263
带金属盖 With metal cover		
M25	UTL-H10B-SFH-4B-MCV-M25	19300102226
2M25	UTL-H10B-SFH-4B-MCV-2M25	19300102266
M32	UTL-H10B-SFH-4B-MCV-M32	19300102227
2M32	UTL-H10B-SFH-4B-MCV-2M32	19300102267
PG21	UTL-H10B-SFH-4B-MCV-PG21	09300102222
2PG21	UTL-H10B-SFH-4B-MCV-2PG21	09300102262
PG29	UTL-H10B-SFH-4B-MCV-PG29	09300102223
2PG29	UTL-H10B-SFH-4B-MCV-2PG29	09300102263

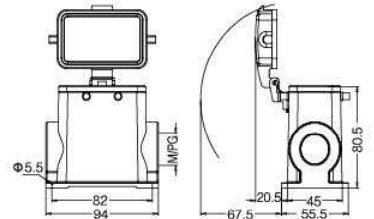

防护盖 Protection covers, metal



接线方式 Connect way	描述 Applications	型号 Type	订货号 Part Number
	金属盖/用于上壳 For hoods	UTL-H10B-MCV-4B/1	09300105427
	金属盖/用于下壳 For housings	UTL-H10B-MCV-4B/2	09300105425

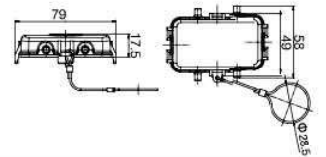

防护盖 Protection covers, metal



接线方式 Connect way	描述 Applications	型号 Type	订货号 Part Number
	金属盖/用于上壳 For hoods	UTL-H10B-MCV-2L.1S	09300105423
	金属盖/用于下壳 For housings	UTL-H10B-MCV-2L.2S	09300105424

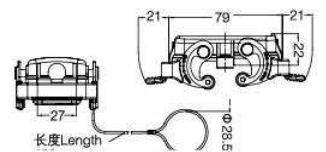

# Metal Hoods & Housings For higher environmental requirements

## 10B 金属外壳 适用于苛刻环境 (耐腐蚀)

防护等级 Degree of protection: IP65

w version

上壳 侧出线 Hoods, side entry



螺纹 Thread	型号 Type	订货号 Part Number
M20	UTL-H10B-MSE-4B-M20	19370101520
PG16	UTL-H10B-MSE-4B-PG16	09370101521

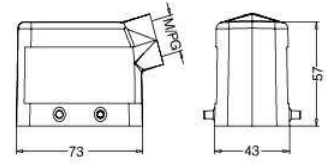

上壳 侧出线 高结构 Hoods, side entry, high construction



螺纹 Thread	型号 Type	订货号 Part Number
M25	UTL-H10B-MSEH-4B-M25	19370100526

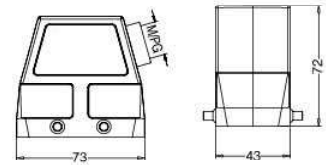

上壳 顶出线 Hoods, top entry



螺纹 Thread	型号 Type	订货号 Part Number
M20	UTL-H10B-MTE-4B-M20	19370101420
PG16	UTL-H10B-MTE-4B-PG16	09370101421

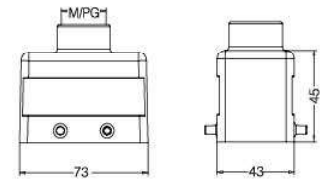

上壳 顶出线 高结构 Hoods, top entry, high construction



螺纹 Thread	型号 Type	订货号 Part Number
M32	UTL-H10B-MTEH-4B-M32	19370100427

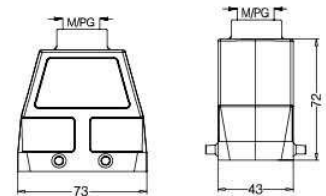

飞线下壳 Housings, cable to cable



螺纹 Thread	型号 Type	订货号 Part Number
PG16	UTL-H10B-MCCT-2L-PG16	09370101731

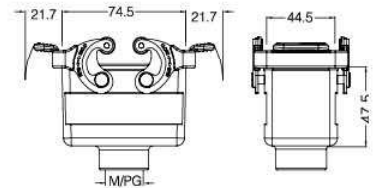

不封底下壳 Housings, bulkhead mounting



螺纹 Thread	型号 Type	订货号 Part Number
---	UTL-H10B-MBK-2L	09370100301

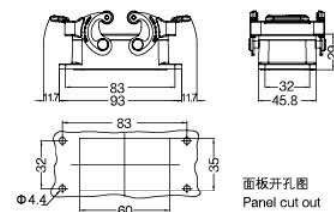

# Metal Hoods & Housings For higher environmental requirements

## 10B 金属外壳 适用于苛刻环境 (耐腐蚀)

### 防护等级 Degree of protection: IP65

上壳 侧出线 Hoods, side entry



螺纹 Thread	型号 Type	订货号 Part Number
M20	UTL-H10B-MSF-2L-2M20	19370101270
PG16	UTL-H10B-MSF-2L-2PG16	09370101271

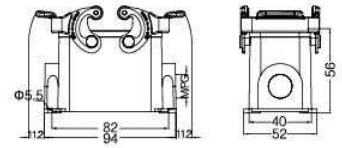

上壳 侧出线 高结构 Hoods, side entry, high construction



螺纹 Thread	型号 Type	订货号 Part Number
M32	UTL-H10B-MSFH-2L-2M32	19370100272

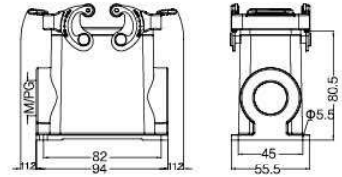

防护盖 Protection covers, metal



螺纹 Thread	型号 Type	订货号 Part Number
---	UTL-H10B-MMCV-2L-1S	09370105403

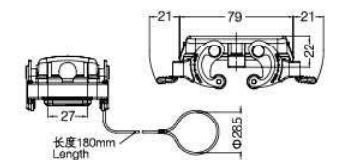

防护盖 Protection covers, metal



螺纹 Thread	型号 Type	订货号 Part Number
---	UTL-H10B-MMCV-4B/2	09370105405

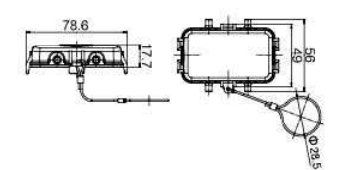

### 防护等级 Degree of protection: IP65 2耳

上壳 顶出线 高结构 Hoods, top entry, high construction



螺纹 Thread	型号 Type	订货号 Part Number
M32	UTL-H10B-MTEH-2B-M32	19370100447

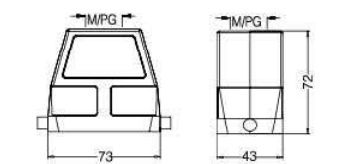

封底下壳 高结构 Housings, surface mounting, high construction



螺纹 Thread	型号 Type	订货号 Part Number
M25	UTL-H10B-MSFH-1L-M25	19370100291

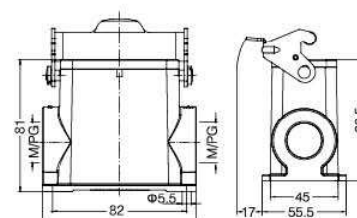

# Hoods & Housings for harsh environmental requirements

## 10B 高防护外壳

防护等级 Degree of protection: IP68

H version

上壳 侧出线 高结构 Hoods, side entry, high construction



螺纹 Thread	型号 Type	订货号 Part Number
螺栓联锁 Screw locking		
M20	UTL-HP10B/H-SEH-2S-M20	19400100510
M25	UTL-HP10B/H-SEH-2S-M25	19400100511
M32	UTL-HP10B/H-SEH-2S-M32	19400100512
M40	UTL-HP10B/H-SEH-2S-M40	19400100513
PG16	UTL-HP10B/H-SEH-2S-PG16	09400100511
PG21	UTL-HP10B/H-SEH-2S-PG21	09400100512
PG29	UTL-HP10B/H-SEH-2S-PG29	09400100513
轴销联锁 Toggle locking		
M20	UTL-HP10B/H-SEH-2T-M20	19400100500
M25	UTL-HP10B/H-SEH-2T-M25	19400100501
M32	UTL-HP10B/H-SEH-2T-M32	19400100502
PG16	UTL-HP10B/H-SEH-2T-PG16	09400100501
PG21	UTL-HP10B/H-SEH-2T-PG21	09400100502
PG29	UTL-HP10B/H-SEH-2T-PG29	09400100503

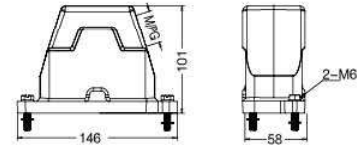

上壳 顶出线 高结构 Hoods, top entry, high construction



螺纹 Thread	型号 Type	订货号 Part Number
螺栓联锁 Screw locking		
M20	UTL-HP10B/H-TEH-2S-M20	19400100410
M25	UTL-HP10B/H-TEH-2S-M25	19400100411
M32	UTL-HP10B/H-TEH-2S-M32	19400100412
M40	UTL-HP10B/H-TEH-2S-M40	19400100413
2M20	UTL-HP10B/H-TEH-2S-2M20	19400100430
PG16	UTL-HP10B/H-TEH-2S-PG16	09400100411
PG21	UTL-HP10B/H-TEH-2S-PG21	09400100412
PG29	UTL-HP10B/H-TEH-2S-PG29	09400100413
轴销联锁 Toggle locking		
M20	UTL-HP10B/H-TEH-2T-M20	19400100400
M25	UTL-HP10B/H-TEH-2T-M25	19400100401
M32	UTL-HP10B/H-TEH-2T-M32	19400100402
PG16	UTL-HP10B/H-TEH-2T-PG16	09400100401
PG21	UTL-HP10B/H-TEH-2T-PG21	09400100402
PG29	UTL-HP10B/H-TEH-2T-PG29	09400100403

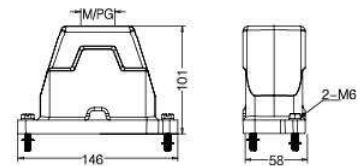

封底下壳 高结构 Housings, surface mounting, high construction



螺纹 Thread	型号 Type	订货号 Part Number
螺栓联锁 Screw locking		
M20	UTL-HP10B/H-SFH-2H-M20	19400101260
M25	UTL-HP10B/H-SFH-2H-M25	19400101261
M32	UTL-HP10B/H-SFH-2H-M32	19400101262
M40	UTL-HP10B/H-SFH-2H-M40	19400101263
2M25	UTL-HP10B/H-SFH-2H-2M25	19400101271
2M32	UTL-HP10B/H-SFH-2H-2M32	19400101272
PG16	UTL-HP10B/H-SFH-2H-PG16	09400101260
PG21	UTL-HP10B/H-SFH-2H-PG21	09400101261
PG29	UTL-HP10B/H-SFH-2H-PG29	09400101262
轴销联锁 Toggle locking		
M20	UTL-HP10B/H-SFH-2T-M20	19400101280
M25	UTL-HP10B/H-SFH-2T-M25	19400101281
M32	UTL-HP10B/H-SFH-2T-M32	19400101282
PG16	UTL-HP10B/H-SFH-2T-PG16	09400101281
PG21	UTL-HP10B/H-SFH-2T-PG21	09400101282
PG29	UTL-HP10B/H-SFH-2T-PG29	09400101283

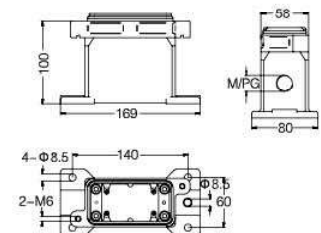



# Hoods & Housings for harsh environmental requirements

## 10B 高防护外壳

**防护等级 Degree of protection: IP68**

**W version**

上壳 侧出线 高结构 Hoods, side entry, high construction



螺纹 Thread	型号 Type	订货号 Part Number
M20	UTL-HP10B-SEH-2S-M20	19400100210
M25	UTL-HP10B-SEH-2S-M25	19400100211
M32	UTL-HP10B-SEH-2S-M32	19400100212
PG16	UTL-HP10B-SEH-2S-PG16	09400100211
PG21	UTL-HP10B-SEH-2S-PG21	09400100212

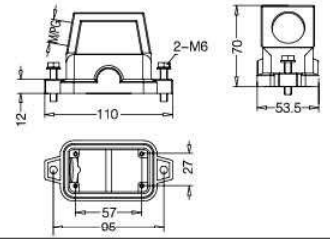

上壳 顶出线 高结构 Hoods, top entry, high construction



螺纹 Thread	型号 Type	订货号 Part Number
M20	UTL-HP10B-TEH-2S-M20	19400100220
M25	UTL-HP10B-TEH-2S-M25	19400100221
M32	UTL-HP10B-TEH-2S-M32	19400100222
PG16	UTL-HP10B-TEH-2S-PG16	09400100221
PG21	UTL-HP10B-TEH-2S-PG21	09400100222
PG29	UTL-HP10B-TEH-2S-PG29	09400100223

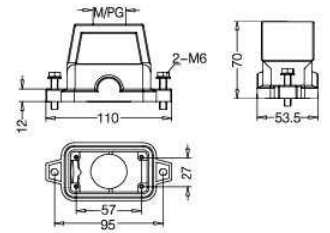

封底下壳 高结构 Housings, surface mounting, high construction



螺纹 Thread	型号 Type	订货号 Part Number
M20	UTL-HP10B-SFH-2H-M20	19400100230
M25	UTL-HP10B-SFH-2H-M25	19400100231
M32	UTL-HP10B-SFH-2H-M32	19400100232
PG16	UTL-HP10B-SFH-2H-PG16	09400100231
PG21	UTL-HP10B-SFH-2H-PG21	09400100232

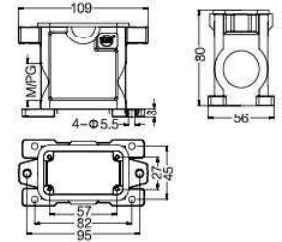

不封底下壳 Housings, bulkhead mounting



螺纹 Thread	型号 Type	订货号 Part Number
---	UTL-HP10B-BK-2H	09400100201

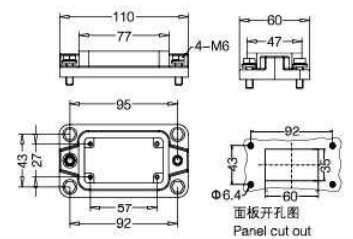

# Hoods & Housings for harsh environmental requirements

## 10B 高防护外壳

防护等级 Degree of protection: IP68

H version

不封底下壳 Housings, bulkhead mounting



螺纹 Thread	型号 Type	订货号 Part Number
---	螺栓联锁 Screw locking	
---	UTL-HP10B/H-BK-2H	09400100311
---	轴销联锁 Toggle locking	
---	UTL-HP10B/H-BK-2T	09400100301
---	带金属盖	
---	螺栓联锁 Screw locking	
---	UTL-HP10B/H-BK-2H-MCV	09400100317
---	轴销联锁 Toggle locking	
---	UTL-HP10B/H-BK-2T-MCV	09400100307

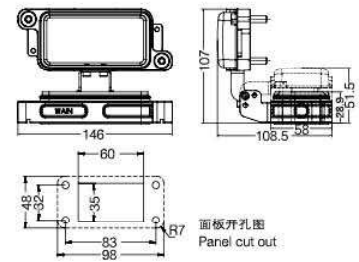

防护盖 Protection covers



螺纹 Thread	型号 Type	订货号 Part Number
---	螺栓联锁 Screw locking	
---	UTL-HP10B/H-MCV-2S	09400105411
---	轴销联锁 Toggle locking	
---	UTL-HP10B/H-MCV-2T	09400105401

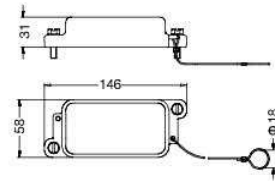

上壳 侧出线 高结构 Hoods, side entry, high construction



螺纹 Thread	型号 Type	订货号 Part Number
M20	UTL-HP10B/H-SEH-4S-M20	19400101360
M25	UTL-HP10B/H-SEH-4S-M25	19400101361
M32	UTL-HP10B/H-SEH-4S-M32	19400101362
M40	UTL-HP10B/H-SEH-4S-M40	19400101363
PG16	UTL-HP10B/H-SEH-4S-PG16	09400101361
PG21	UTL-HP10B/H-SEH-4S-PG21	09400101362

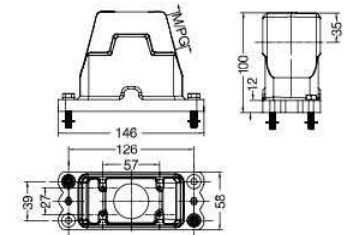

上壳 顶出线 高结构 Hoods, top entry, high construction



螺纹 Thread	型号 Type	订货号 Part Number
M20	UTL-HP10B/H-TEH-4S-M20	19400101460
M25	UTL-HP10B/H-TEH-4S-M25	19400101461
M32	UTL-HP10B/H-TEH-4S-M32	19400101462
M40	UTL-HP10B/H-TEH-4S-M40	19400101463
PG16	UTL-HP10B/H-TEH-4S-PG16	09400101461
PG21	UTL-HP10B/H-TEH-4S-PG21	09400101462
PG29	UTL-HP10B/H-TEH-4S-PG29	09400101463

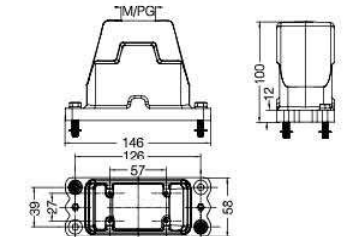

不封底下壳 Housings, bulkhead mounting



螺纹 Thread	型号 Type	订货号 Part Number
---	UTL-HP10B/H-BK-4H	09400100202

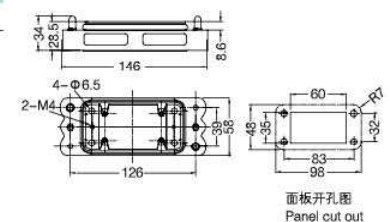

# Hoods & Housings for harsh environmental requirements

## 10B 高防护外壳

**防护等级 Degree of protection: IP68**

上壳 侧出线 高结构 Hoods, side entry, high construction



螺纹 Thread	型号 Type	订货号 Part Number
M25	UTL-HC10B-SEH-2S-M25	19400101500
M32	UTL-HC10B-SEH-2S-M32	19400101501
PG16	UTL-HC10B-SEH-2S-PG16	09400101500
PG21	UTL-HC10B-SEH-2S-PG21	09400101501

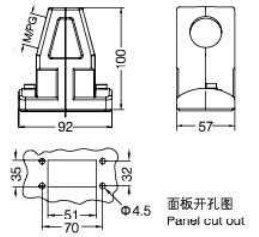

上壳 顶出线 高结构 Hoods, top entry, high construction



螺纹 Thread	型号 Type	订货号 Part Number
M25	UTL-HC10B-TEH-2S-M25	19400101550
M32	UTL-HC10B-TEH-2S-M32	19400101551
PG16	UTL-HC10B-TEH-2S-PG16	09400101550
PG21	UTL-HC10B-TEH-2S-PG21	09400101551

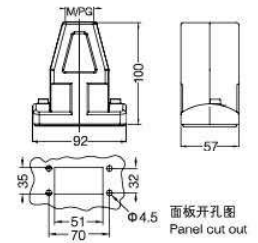

芯体安装支块 Protection covers



描述 Application	型号 Type	订货号 Part Number
整体型外壳适配 For integral type hoods	UTL-APT-C	09400101600

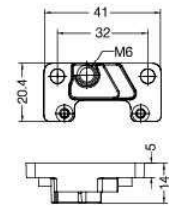

# Metal Hoods & Housings For High Voltage Inserts(HVE Series)

## HV10B 金属外壳用于高电压插芯 (HVE 系列)

**防护等级 Degree of protection: IP65**

上壳 侧出线 Hoods, side entry



螺纹 Thread	型号 Type	订货号 Part Number
M20	UTL-HV10B-SE-2B-M20	19340101540
PG16	UTL-HV10B-SE-2B-PG16	09340101541

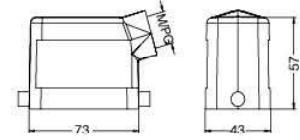

上壳 侧出线 高结构 Hoods, side entry, high construction



螺纹 Thread	型号 Type	订货号 Part Number
M25	UTL-HV10B-SEH-2B-M25	19340100546
M32	UTL-HV10B-SEH-2B-M32	19340100547
PG21	UTL-HV10B-SEH-2B-PG21	09340100542
PG29	UTL-HV10B-SEH-2B-PG29	09340100543

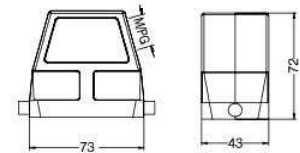

上壳 顶出线 Hoods, top entry



螺纹 Thread	型号 Type	订货号 Part Number
M20	UTL-HV10B-TE-2B-M20	19340101440
PG16	UTL-HV10B-TE-2B-PG16	09340101441

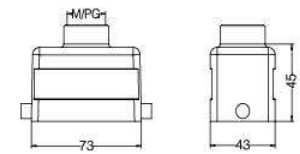

上壳 顶出线 高结构 Hoods, top entry, high construction



螺纹 Thread	型号 Type	订货号 Part Number
M25	UTL-HV10B-TEH-2B-M25	19340100446
M32	UTL-HV10B-TEH-2B-M32	19340100447
PG21	UTL-HV10B-TEH-2B-PG21	09340100442
PG29	UTL-HV10B-TEH-2B-PG29	09340100443

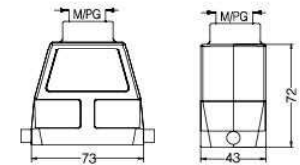

飞线下壳 Housings, cable to cable



螺纹 Thread	型号 Type	订货号 Part Number
M20	UTL-HV10B-CCT-1L-M20	19340101750
PG16	UTL-HV10B-CCT-1L-PG16	09340101751

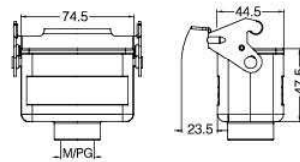

飞线下壳 高结构 Housings, cable to cable, high construction



螺纹 Thread	型号 Type	订货号 Part Number
M25	UTL-HV10B-CCTH-1L-M25	19340100756
M32	UTL-HV10B-CCTH-1L-M32	19340100757
PG21	UTL-HV10B-CCTH-1L-PG21	09340100752
PG29	UTL-HV10B-CCTH-1L-PG29	09340100753

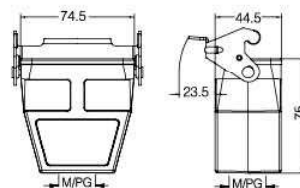

# Metal Hoods & Housings For High Voltage Inserts(HVE Series) HV10B 金属外壳用于高电压插芯 (HVE 系列)

**防护等级 Degree of protection: IP65**

不封底下壳 Housings, bulkhead mounting



螺纹 Thread	型号 Type	订货号 Part Number
---	UTL-HV10B-BK-1L 带塑料盖 With plastic cover	09340100305
---	UTL-HV10B-BK-1L-CV 带金属盖 With metal cover	09340100303
---	UTL-HV10B-BK-1L-MCV	09340100318

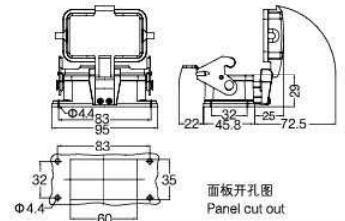

封底下壳 Housings, surface mounting



螺纹 Thread	型号 Type	订货号 Part Number
M20	UTL-HV10B-SF-1L-M20	19340101250
2M20	UTL-HV10B-SF-1L-2M20	19340101290
M25	UTL-HV10B-SF-1L-M25	19340101251
2M25	UTL-HV10B-SF-1L-2M25	19340101291
PG16	UTL-HV10B-SF-1L-PG16	09340101251
2PG16	UTL-HV10B-SF-1L-2PG16	09340101291
	带塑料盖 With plastic cover	
M20	UTL-HV10B-SF-1L-CV-M20	19340101255
2M20	UTL-HV10B-SF-1L-CV-2M20	19340101295
M25	UTL-HV10B-SF-1L-CV-M25	19340101256
2M25	UTL-HV10B-SF-1L-CV-2M25	19340101296
PG16	UTL-HV10B-SF-1L-CV-PG16	09340101256
2PG16	UTL-HV10B-SF-1L-CV-2PG16	09340101296
	带金属盖 With metal cover	
M20	UTL-HV10B-SF-1L-MCV-M20	19340102255
2M20	UTL-HV10B-SF-1L-MCV-2M20	19340102295
M25	UTL-HV10B-SF-1L-MCV-M25	19340102256
2M25	UTL-HV10B-SF-1L-MCV-2M25	19340102296
PG16	UTL-HV10B-SF-1L-MCV-PG16	09340102256
2PG16	UTL-HV10B-SF-1L-MCV-2PG16	09340102296

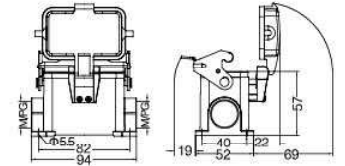

封底下壳 高结构 Housings, surface mounting, high construction



螺纹 Thread	型号 Type	订货号 Part Number
M25	UTL-HV10B-SFH-1L-M25	19340100291
2M25	UTL-HV10B-SFH-1L-2M25	19340100391
M32	UTL-HV10B-SFH-1L-M32	19340100292
2M32	UTL-HV10B-SFH-1L-2M32	19340100392
PG21	UTL-HV10B-SFH-1L-PG21	09340100192
2PG21	UTL-HV10B-SFH-1L-2PG21	09340100292
PG29	UTL-HV10B-SFH-1L-PG29	09340100193
2PG29	UTL-HV10B-SFH-1L-2PG29	09340100293
	带塑料盖 With plastic cover	
M25	UTL-HV10B-SFH-1L-CV-M25	19340100196
2M25	UTL-HV10B-SFH-1L-CV-2M25	19340100296
M32	UTL-HV10B-SFH-1L-CV-M32	19340100197
2M32	UTL-HV10B-SFH-1L-CV-2M32	19340100297
PG21	UTL-HV10B-SFH-1L-CV-PG21	09340100197
2PG21	UTL-HV10B-SFH-1L-CV-2PG21	09340100297
PG29	UTL-HV10B-SFH-1L-CV-PG29	09340100198
2PG29	UTL-HV10B-SFH-1L-CV-2PG29	09340100298
	带金属盖 With metal cover	
M25	UTL-HV10B-SFH-1L-MCV-M25	19340107295
2M25	UTL-HV10B-SFH-1L-MCV-2M25	19340107296
M32	UTL-HV10B-SFH-1L-MCV-M32	19340107297
2M32	UTL-HV10B-SFH-1L-MCV-2M32	19340107298
PG21	UTL-HV10B-SFH-1L-MCV-PG21	09340102197
2PG21	UTL-HV10B-SFH-1L-MCV-2PG21	09340102297
PG29	UTL-HV10B-SFH-1L-MCV-PG29	09340102198
2PG29	UTL-HV10B-SFH-1L-MCV-2PG29	09340102298

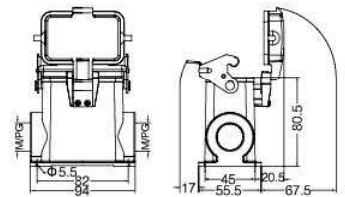

# Metal Hoods & Housings For High Voltage Inserts(HVE Series)

## HV10B 金属外壳用于高电压插芯 (HVE 系列)

**防护等级 Degree of protection: IP65**

上壳 侧出线 Hoods, side entry



螺纹 Thread	型号 Type	订货号 Part Number
M20	UTL-HV10B-SE-4B-M20	19340100520
PG16	UTL-HV10B-SE-4B-PG16	09340100521

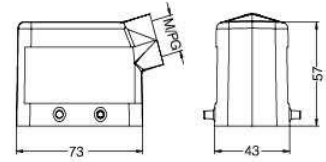

上壳 侧出线 高结构 Hoods, side entry, high construction



螺纹 Thread	型号 Type	订货号 Part Number
M25	UTL-HV10B-SEH-4B-M25	19340100551
M32	UTL-HV10B-SEH-4B-M32	19340100552
PG21	UTL-HV10B-SEH-4B-PG21	09340100552
PG29	UTL-HV10B-SEH-4B-PG29	09340100553

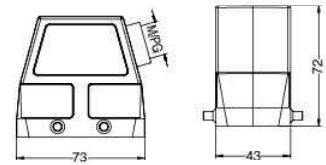

上壳 顶出线 Hoods, top entry



螺纹 Thread	型号 Type	订货号 Part Number
M20	UTL-HV10B-TE-4B-M20	19340100420
M25	UTL-HV10B-TE-4B-M25	19340100421
PG16	UTL-HV10B-TE-4B-PG16	09340100421

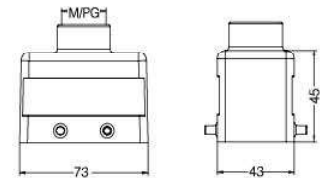

上壳 顶出线 高结构 Hoods, top entry, high construction



螺纹 Thread	型号 Type	订货号 Part Number
M25	UTL-HV10B-TEH-4B-M25	19340100451
M32	UTL-HV10B-TEH-4B-M32	19340100452
PG21	UTL-HV10B-TEH-4B-PG21	09340100452
PG29	UTL-HV10B-TEH-4B-PG29	09340100453

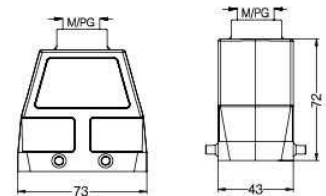

不封底下壳 Housings, bulkhead mounting



螺纹 Thread	型号 Type	订货号 Part Number
---	UTL-HV10B-BK-2L	09340100301

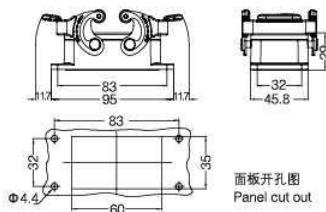

封底下壳 Housings, surface mounting



螺纹 Thread	型号 Type	订货号 Part Number
M20	UTL-HV10B-SF-2L-M20	19340100270
2M20	UTL-HV10B-SF-2L-2M20	19340100275
M25	UTL-HV10B-SF-2L-M25	19340100271
2M25	UTL-HV10B-SF-2L-2M25	19340100276
PG16	UTL-HV10B-SF-2L-PG16	09340100271
2PG16	UTL-HV10B-SF-2L-2PG16	09340100276

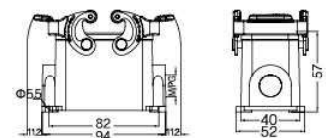

# Metal Hoods & Housings For High Voltage inserts(HVE Series) HV10B 金属外壳用于高电压插芯 (HVE 系列)

**防护等级 Degree of protection: IP65**

封底下壳 高结构 Housings, surface mounting, high construction



螺纹 Thread	型号 Type	订货号 Part Number
M25	UTL-HV10B-SFH-2L-M25	19340100231
2M25	UTL-HV10B-SFH-2L-2M25	19340100276
M32	UTL-HV10B-SFH-2L-M32	19340100232
2M32	UTL-HV10B-SFH-2L-2M32	19340100272
PG21	UTL-HV10B-SFH-2L-PG21	09340100232
2PG21	UTL-HV10B-SFH-2L-2PG21	09340100272
PG29	UTL-HV10B-SFH-2L-PG29	09340100233
2PG29	UTL-HV10B-SFH-2L-2PG29	09340100273

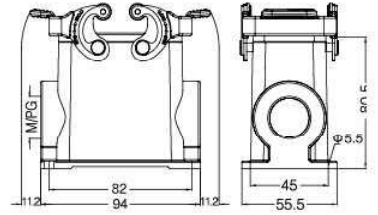

飞线下壳 Housings, cable to cable



螺纹 Thread	型号 Type	订货号 Part Number
M20	UTL-HV10B-CCT-2L-M20	19340100730
M25	UTL-HV10B-CCT-2L-M25	19340100731
PG16	UTL-HV10B-CCT-2L-PG16	09340101731

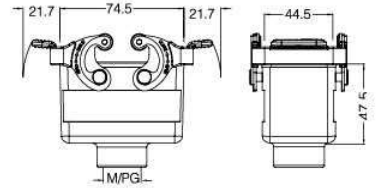

飞线下壳 高结构 Housings, cable to cable, high construction



螺纹 Thread	型号 Type	订货号 Part Number
M25	UTL-HV10B-CCTH-2L-M25	19340100736
M32	UTL-HV10B-CCTH-2L-M32	19340100737
PG21	UTL-HV10B-CCTH-2L-PG21	09340100732
PG29	UTL-HV10B-CCTH-2L-PG29	09340100733

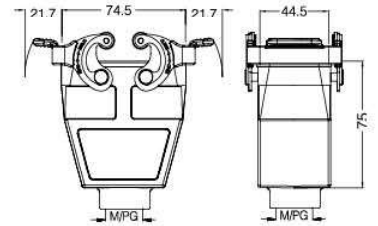

塑料防护盖 4卡扣 Protection covers, plastic



接线方式 Connect way	描述 Applications	型号 Type	订货号 Part Number
---	用于上壳 For hoods	UTL-H10B-CV-4C	09340105401

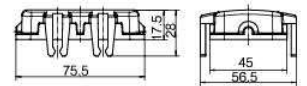

塑料防护盖 Protection covers, plastic



接线方式 Connect way	描述 Applications	型号 Type	订货号 Part Number
	塑料盖/用于飞线下壳 For Housings,cable to cable	UTL-H10B-CV-4B/1	09300105426
	塑料盖/用于不封底,封底下壳 For housing,bulkhead/ UTL-H10B-CV-4B/2 surface mounting	UTL-H10B-CV-4B/2	09300105428

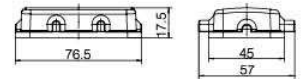

# Metal Hoods & Housings For High Voltage inserts(HVE Series)

## HV10B 金属外壳用于高电压插芯 (HVE 系列)

**防护等级 Degree of protection: IP65**

上壳 侧出线 Hoods, side entry



螺纹 Thread	型号 Type	订货号 Part Number
M20	UTL-HV10B-SE-2L-M20	19340101530
PG16	UTL-HV10B-SE-2L-PG16	09340101531

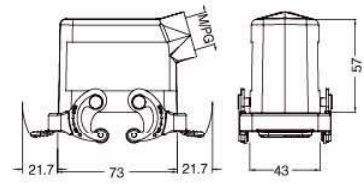

上壳 侧出线 高结构 Hoods, side entry, high construction



螺纹 Thread	型号 Type	订货号 Part Number
M25	UTL-HV10B-SEH-2L-M25	19340100536
M32	UTL-HV10B-SEH-2L-M32	19340100537
PG21	UTL-HV10B-SEH-2L-PG21	09340100532
PG29	UTL-HV10B-SEH-2L-PG29	09340100533

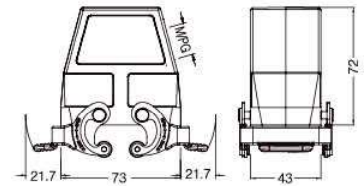

上壳 顶出线 Hoods, top entry



螺纹 Thread	型号 Type	订货号 Part Number
M20	UTL-HV10B-TE-2L-M20	19340101430
PG16	UTL-HV10B-TE-2L-PG16	09340101431

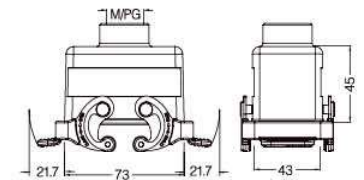

上壳 顶出线 高结构 Hoods, top entry, high construction



螺纹 Thread	型号 Type	订货号 Part Number
M25	UTL-HV10B-TEH-2L-M25	19340100436
M32	UTL-HV10B-TEH-2L-M32	19340100437
PG21	UTL-HV10B-TEH-2L-PG21	09340100432
PG29	UTL-HV10B-TEH-2L-PG29	09340100433

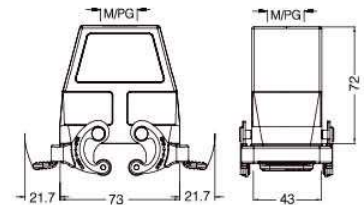

不封底下壳 Housings, bulkhead mounting



螺纹 Thread	型号 Type	订货号 Part Number
---	UTL-HV10B-BK-4B	09300100300
---	带塑料盖 With plastic cover	
---	UTL-HV10B-BK-4B-CV	09340100302
---	带金属盖 With metal cover	
---	UTL-HV10B-BK-4B-MCV	09340100317

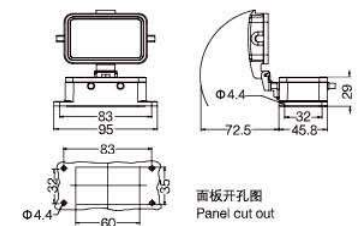



# Metal Hoods & Housings For High Voltage Inserts(HVE Series) HV10B 金属外壳用于高电压插芯 (HVE 系列)

防护等级 Degree of protection: IP65

封底下壳 Housings, surface mounting



螺纹 Thread	型号 Type	订货号 Part Number
M20	UTL-HV10B-SF-4B-M20	19340101125
2M20	UTL-HV10B-SF-4B-2M20	19340101165
M25	UTL-HV10B-SF-4B-M25	19340101126
2M25	UTL-HV10B-SF-4B-2M25	19340101166
PG16	UTL-HV10B-SF-4B-PG16	09340101121
2PG16	UTL-HV10B-SF-4B-2PG16	09340101161
带塑料盖 With plastic cover		
M20	UTL-HV10B-SF-4B-CV-M20	19340101225
2M20	UTL-HV10B-SF-4B-CV-2M20	19340101265
M25	UTL-HV10B-SF-4B-CV-M25	19340101226
2M25	UTL-HV10B-SF-4B-CV-2M25	19340101266
PG16	UTL-HV10B-SF-4B-CV-PG16	09340101221
2PG16	UTL-HV10B-SF-4B-CV-2PG16	09340101261
带金属盖 With metal cover		
M20	UTL-HV10B-SF-4B-MCV-M20	19340102225
2M20	UTL-HV10B-SF-4B-MCV-2M20	19340102265
M25	UTL-HV10B-SF-4B-MCV-M25	19340102226
2M25	UTL-HV10B-SF-4B-MCV-2M25	19340102266
PG16	UTL-HV10B-SF-4B-MCV-PG16	09340102221
2PG16	UTL-HV10B-SF-4B-MCV-2PG16	09340102261

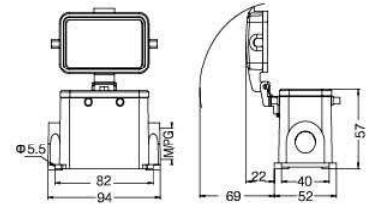

封底下壳 高结构 Housings, surface mounting, high construction



螺纹 Thread	型号 Type	订货号 Part Number
M25	UTL-HV10B-SFH-4B-M25	19340100126
2M25	UTL-HV10B-SFH-4B-2M25	19340100166
M32	UTL-HV10B-SFH-4B-M32	19340100127
2M32	UTL-HV10B-SFH-4B-2M32	19340100167
PG21	UTL-HV10B-SFH-4B-PG21	09340100122
2PG21	UTL-HV10B-SFH-4B-2PG21	09340100162
PG29	UTL-HV10B-SFH-4B-PG29	09340100123
2PG29	UTL-HV10B-SFH-4B-2PG29	09340100163
带塑料盖 With plastic cover		
M25	UTL-HV10B-SFH-4B-CV-M25	19340100226
2M25	UTL-HV10B-SFH-4B-CV-2M25	19340100266
M32	UTL-HV10B-SFH-4B-CV-M32	19340100227
2M32	UTL-HV10B-SFH-4B-CV-2M32	19340100267
PG21	UTL-HV10B-SFH-4B-CV-PG21	09340100222
2PG21	UTL-HV10B-SFH-4B-CV-2PG21	09340100262
PG29	UTL-HV10B-SFH-4B-CV-PG29	09340100223
2PG29	UTL-HV10B-SFH-4B-CV-2PG29	09340100263
带金属盖 With metal cover		
M25	UTL-HV10B-SFH-4B-MCV-M25	19340102226
2M25	UTL-HV10B-SFH-4B-MCV-2M25	19340102266
M32	UTL-HV10B-SFH-4B-MCV-M32	19340102227
2M32	UTL-HV10B-SFH-4B-MCV-2M32	19340102267
PG21	UTL-HV10B-SFH-4B-MCV-PG21	09340102222
2PG21	UTL-HV10B-SFH-4B-MCV-2PG21	09340102262
PG29	UTL-HV10B-SFH-4B-MCV-PG29	09340102223
2PG29	UTL-HV10B-SFH-4B-MCV-2PG29	09340102263

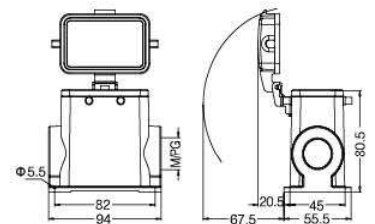

防护盖 Protection covers, metal



接线方式 Connect way	描述 Applications	型号 Type	订货号 Part Number
	金属盖/用于上壳 For hoods	UTL-H10B-MCV-4B/1	09340105457
	金属盖/用于下壳 For housings	UTL-H10B-MCV-4B/2	09340105458

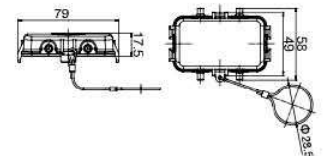

防护盖 Protection covers, metal



接线方式 Connect way	描述 Applications	型号 Type	订货号 Part Number
	金属盖/用于上壳 For hoods	UTL-H10B-MCV-2L.1S	09340105423
	金属盖/用于下壳 For housings	UTL-H10B-MCV-2L.2S	09340105424

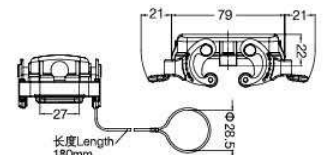

# Plastic Hoods & Housings

## 16B 塑料外壳

**防护等级 Degree of protection: IP65**

上壳 侧出线 高结构 Hoods, side entry, high construction



螺纹 Thread	型号 Type	订货号 Part Number
M32	UTL-H16B.P-SEH-4B-M32	19300160111
M40	UTL-H16B.P-SEH-4B-M40	19300160112

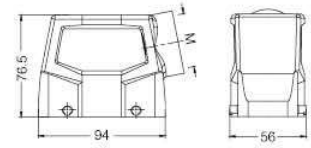

上壳 顶出线 高结构 Hoods, top entry, high construction



螺纹 Thread	型号 Type	订货号 Part Number
M32	UTL-H16B.P-TEH-4B-M32	19300160121
M40	UTL-H16B.P-TEH-4B-M40	19300160122

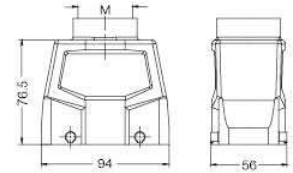

不封底下壳 Housings, bulkhead mounting



螺纹 Thread	型号 Type	订货号 Part Number
---	UTL-H16B.P-BK-2L	09300160300

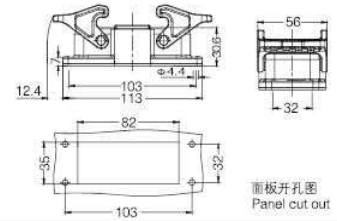

封底下壳 高结构 Housings, surface mounting, high construction



螺纹 Thread	型号 Type	订货号 Part Number
M32	UTL-H16B.P-SFH-2L-M32	19300160132
2M32	UTL-H16B.P-SFH-2L-2M32	19300160136
M40	UTL-H16B.P-SFH-2L-M40	19300160133
2M40	UTL-H16B.P-SFH-2L-2M40	19300160137

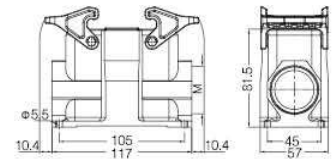

防护盖 Protection covers, metal



螺纹 Thread	型号 Type	订货号 Part Number
---	UTL-H16B.P-CV-4B/2	09300160140

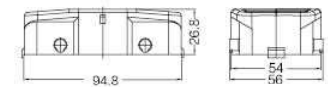

防护盖 Protection covers, metal



螺纹 Thread	型号 Type	订货号 Part Number
---	UTL-H16B.P-CV-2L/1	09300160145

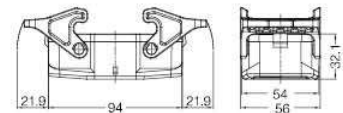

# Plastic Hoods & Housings

## 16B 塑料外壳

**防护等级 Degree of protection: IP65**

上壳 侧出线 Hoods, side entry



螺纹 Thread	型号 Type	订货号 Part Number
M25	UTL-H16B-SE-2B-M25	19300161541
M32	UTL-H16B-SE-2B-M32	19300161542
PG21	UTL-H16B-SE-2B-PG21	09300161540

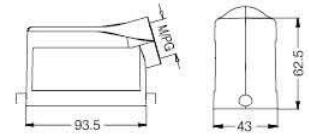

上壳 侧出线 高结构 Hoods, side entry, high construction



螺纹 Thread	型号 Type	订货号 Part Number
M32	UTL-H16B-SEH-2B-M32	19300160547
M40	UTL-H16B-SEH-2B-M40	19300160548
PG21	UTL-H16B-SEH-2B-PG21	09300160540
PG29	UTL-H16B-SEH-2B-PG29	09300160541

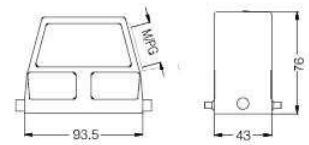

上壳 顶出线 Hoods, top entry



螺纹 Thread	型号 Type	订货号 Part Number
M25	UTL-H16B-TE-2B-M25	19300161441
M32	UTL-H16B-TE-2B-M32	19300161442
PG21	UTL-H16B-TE-2B-PG21	09300161440

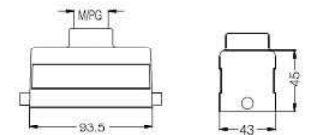

上壳 顶出线 高结构 Hoods, top entry, high construction



螺纹 Thread	型号 Type	订货号 Part Number
M32	UTL-H16B-TEH-2B-M32	19300160447
M40	UTL-H16B-TEH-2B-M40	19300160448
PG21	UTL-H16B-TEH-2B-PG21	09300160440
PG29	UTL-H16B-TEH-2B-PG29	09300160441

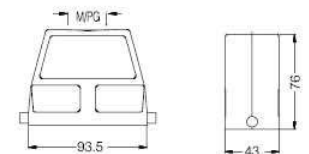

飞线下壳 Housings, cable to cable



螺纹 Thread	型号 Type	订货号 Part Number
M25	UTL-H16B-CCT-1L-M25	19300161751
M32	UTL-H16B-CCT-1L-M32	19300161752
PG21	UTL-H16B-CCT-1L-PG21	09300161750

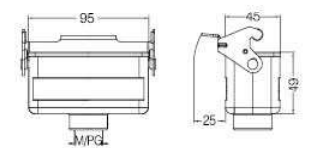

飞线下壳 高结构 Housings, cable to cable, high construction



螺纹 Thread	型号 Type	订货号 Part Number
M32	UTL-H16B-CCTH-1L-M32	19300160757
M40	UTL-H16B-CCTH-1L-M40	19300160758
PG21	UTL-H16B-CCTH-1L-PG21	09300160750
PG29	UTL-H16B-CCTH-1L-PG29	09300160751

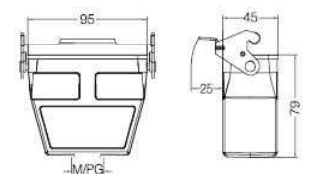

# Metal Hoods & Housings

## 16B 金属外壳

### 防护等级 Degree of protection: IP65

不封底下壳 Housings, bulkhead mounting



螺纹 Thread	型号 Type	订货号 Part Number
---	UTL-H16B-BK-1L	09300160307
	带塑料盖 With plastic cover	
---	UTL-H16B-BK-1L-CV	09300160306
	带金属盖 With metal cover	
---	UTL-H16B-BK-1L-MCV	09300160318

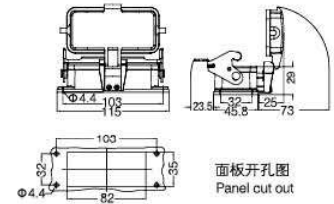

封底下壳 Housings, surface mounting



螺纹 Thread	型号 Type	订货号 Part Number
M25	UTL-H16B-SF-1L-M25	19300161251
2M25	UTL-H16B-SF-1L-2M25	19300161291
PG21	UTL-H16B-SF-1L-PG21	09300161250
2PG21	UTL-H16B-SF-1L-2PG21	09300161290
	带塑料盖 With plastic cover	
M25	UTL-H16B-SF-1L-CV-M25	19300161256
2M25	UTL-H16B-SF-1L-CV-2M25	19300161296
PG21	UTL-H16B-SF-1L-CV-PG21	09300161255
2PG21	UTL-H16B-SF-1L-CV-2PG21	09300161295
	带金属盖 With metal cover	
M25	UTL-H16B-SF-1L-MCV-M25	19300162256
2M25	UTL-H16B-SF-1L-MCV-2M25	19300162296
PG21	UTL-H16B-SF-1L-MCV-PG21	09300162255
2PG21	UTL-H16B-SF-1L-MCV-2PG21	09300162295

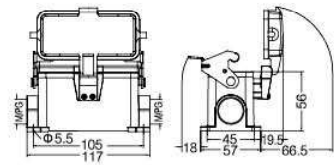

封底下壳 高结构 Housings, surface mounting, high construction



螺纹 Thread	型号 Type	订货号 Part Number
M32	UTL-H16B-SFH-1L-M32	19300160252
2M25	UTL-H16B-SFH-1L-2M25	19300160291
2M32	UTL-H16B-SFH-1L-2M32	19300160292
PG21	UTL-H16B-SFH-1L-PG21	09300160250
2PG21	UTL-H16B-SFH-1L-2PG21	09300160290
PG29	UTL-H16B-SFH-1L-PG29	09300160251
2PG29	UTL-H16B-SFH-1L-2PG29	09300160291
	带塑料盖 With plastic cover	
M32	UTL-H16B-SFH-1L-CV-M32	19300160257
2M32	UTL-H16B-SFH-1L-CV-2M32	19300160297
PG21	UTL-H16B-SFH-1L-CV-PG21	09300160255
2PG21	UTL-H16B-SFH-1L-CV-2PG21	09300160295
PG29	UTL-H16B-SFH-1L-CV-PG29	09300160256
2PG29	UTL-H16B-SFH-1L-CV-2PG29	09300160296
	带金属盖 With metal cover	
M32	UTL-H16B-SFH-1L-MCV-M32	19300167257
2M32	UTL-H16B-SFH-1L-MCV-2M32	19300167297
PG21	UTL-H16B-SFH-1L-MCV-PG21	09300162257
2PG21	UTL-H16B-SFH-1L-MCV-2PG21	09300162297
PG29	UTL-H16B-SFH-1L-MCV-PG29	09300162258
2PG29	UTL-H16B-SFH-1L-MCV-2PG29	09300162298

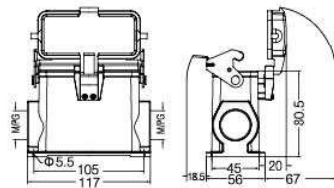

# Metal Hoods & Housings

## 16B 金属外壳

**防护等级 Degree of protection: IP65**

上壳 侧出线 Hoods, side entry



螺纹 Thread	型号 Type	订货号 Part Number
M25	UTL-H16B-SE-4B-M25	19300161521
M32	UTL-H16B-SE-4B-M32	19300161522
PG21	UTL-H16B-SE-4B-PG21	09300161520

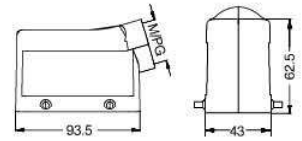

上壳 侧出线 高结构 Hoods, side entry, high construction



螺纹 Thread	型号 Type	订货号 Part Number
M25	UTL-H16B-SEH-4B-M25	19300160526
M32	UTL-H16B-SEH-4B-M32	19300160527
M40	UTL-H16B-SEH-4B-M40	19300160528
PG21	UTL-H16B-SEH-4B-PG21	09300160520
PG29	UTL-H16B-SEH-4B-PG29	09300160521

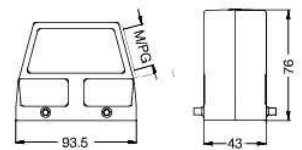

我司可提供顶部、侧面同时出线的非标品, 详见P17-08  
We can provide non-standard products with both top&side entry, see P17-08

上壳 顶出线 Hoods, top entry



螺纹 Thread	型号 Type	订货号 Part Number
M25	UTL-H16B-TE-4B-M25	19300161421
M32	UTL-H16B-TE-4B-M32	19300161422
PG21	UTL-H16B-TE-4B-PG21	09300161420

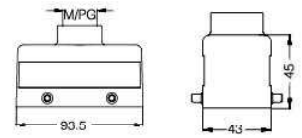

上壳 顶出线 高结构 Hoods, top entry, high construction



螺纹 Thread	型号 Type	订货号 Part Number
M32	UTL-H16B-TEH-4B-M32	19300160427
M40	UTL-H16B-TEH-4B-M40	19300160428
PG21	UTL-H16B-TEH-4B-PG21	09300160420
PG29	UTL-H16B-TEH-4B-PG29	09300160421
2M25	UTL-H16B-TEH-4B-2M25	19300160466
2PG16	UTL-H16B-TEH-4B-2PG16	09300160461
2PG21	UTL-H16B-TEH-4B-2PG21	09300160462



不封底下壳 Housings, bulkhead mounting



螺纹 Thread	型号 Type	订货号 Part Number
---	UTL-H16B-BK-2L	09300160301

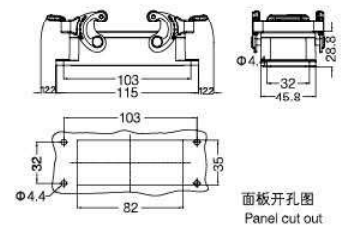

封底下壳 Housings, surface mounting



螺纹 Thread	型号 Type	订货号 Part Number
M25	UTL-H16B-SF-2L-M25	19300161231
2M25	UTL-H16B-SF-2L-2M25	19300161271
PG21	UTL-H16B-SF-2L-PG21	09300161230
2PG21	UTL-H16B-SF-2L-2PG21	09300161270

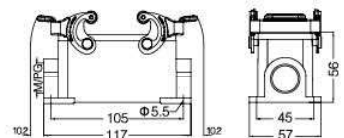

# Metal Hoods & Housings

## 16B 金属外壳

### 防护等级 Degree of protection: IP65

封底下壳 高结构 Housings, surface mounting, high construction



螺纹 Thread	型号 Type	订货号 Part Number
2M25	UTL-H16B-SFH-2L-2M25	19300160271
M32	UTL-H16B-SFH-2L-M32	19300160232
2M32	UTL-H16B-SFH-2L-2M32	19300160272
2M40	UTL-H16B-SFH-2L-2M40	19300160273
PG21	UTL-H16B-SFH-2L-PG21	09300160230
2PG21	UTL-H16B-SFH-2L-2PG21	09300160270
PG29	UTL-H16B-SFH-2L-PG29	09300160231
2PG29	UTL-H16B-SFH-2L-2PG29	09300160271

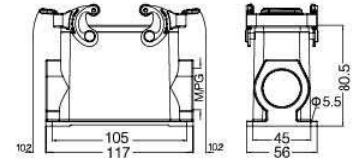

飞线下壳 Housings, cable to cable



螺纹 Thread	型号 Type	订货号 Part Number
M25	UTL-H16B-CCT-2L-M25	19300161731
M32	UTL-H16B-CCT-2L-M32	19300161732
PG21	UTL-H16B-CCT-2L-PG21	09300161730

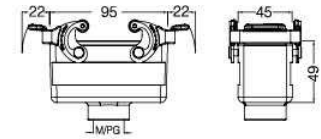

飞线下壳 高结构 Housings, cable to cable, high construction



螺纹 Thread	型号 Type	订货号 Part Number
M25	UTL-H16B-CCTH-2L-M25	19300160736
M32	UTL-H16B-CCTH-2L-M32	19300160737
M40	UTL-H16B-CCTH-2L-M40	19300160738
PG21	UTL-H16B-CCTH-2L-PG21	09300160730
PG29	UTL-H16B-CCTH-2L-PG29	09300160731

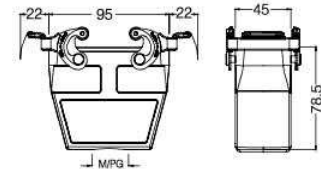

塑料防护盖 4卡扣 Protection covers, plastic



接线方式 Connect way	描述 Applications	型号 Type	订货号 Part Number
---	用于上壳	UTL-H16B-CV-4C	09300165401

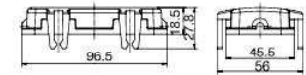

塑料防护盖 Protection covers, plastic



接线方式 Connect way	描述 Applications	型号 Type	订货号 Part Number
	塑料盖/用于飞线下壳 For Housings, cable to cable	UTL-H16B-CV-4B/1	09300165427
	塑料盖/用于不封底,封底下壳 For housing, bulkhead/ surface mounting	UTL-H16B-CV-4B/2	09300165428

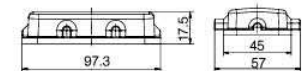

# Metal Hoods & Housings

## 16B 金属外壳

**防护等级 Degree of protection: IP65**

上壳 侧出线 Hoods, side entry



螺纹 Thread	型号 Type	订货号 Part Number
M25	UTL-H16B-SE-2L-M25	19300161531
M32	UTL-H16B-SE-2L-M32	19300161532
PG21	UTL-H16B-SE-2L-PG21	09300161530

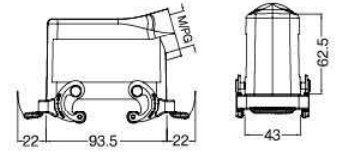

上壳 侧出线 高结构 Hoods, side entry, high construction



螺纹 Thread	型号 Type	订货号 Part Number
M25	UTL-H16B-SEH-2L-M25	19300160536
M32	UTL-H16B-SEH-2L-M32	19300160537
M40	UTL-H16B-SEH-2L-M40	19300160538
PG21	UTL-H16B-SEH-2L-PG21	09300160530
PG29	UTL-H16B-SEH-2L-PG29	09300160531

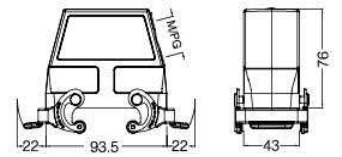

上壳 顶出线 Hoods, top entry



螺纹 Thread	型号 Type	订货号 Part Number
M25	UTL-H16B-TE-2L-M25	19300161431
M32	UTL-H16B-TE-2L-M32	19300161432
PG21	UTL-H16B-TE-2L-PG21	09300161430

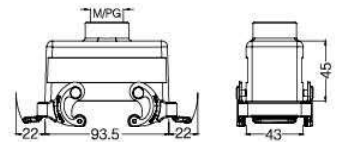

上壳 顶出线 高结构 Hoods, top entry, high construction



螺纹 Thread	型号 Type	订货号 Part Number
M32	UTL-H16B-TEH-2L-M32	19300160437
M40	UTL-H16B-TEH-2L-M40	19300160438
PG21	UTL-H16B-TEH-2L-PG21	09300160430
PG29	UTL-H16B-TEH-2L-PG29	09300160431

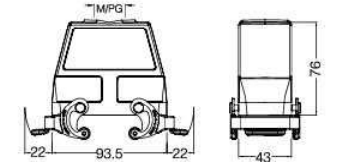

不封底下壳 Housings, bulkhead mounting



螺纹 Thread	型号 Type	订货号 Part Number
---	UTL-H16B-BK-4B	09300160300
	带塑料盖 With plastic cover	
---	UTL-H16B-BK-4B-CV	09300160302
	带金属盖 With metal cover	
---	UTL-H16B-BK-4B-MCV	09300160317

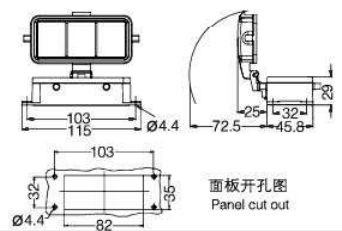

# Metal Hoods & Housings

## 16B 金属外壳

防护等级 Degree of protection: IP65

封底下壳 Housings, surface mounting



螺纹 Thread	型号 Type	订货号 Part Number
M25	UTL-H16B-SF-4B-M25	19300161126
2M25	UTL-H16B-SF-4B-2M25	19300161166
PG21	UTL-H16B-SF-4B-PG21	09300161120
2PG21	UTL-H16B-SF-4B-2PG21	09300161160
带塑料盖 With plastic cover		
M25	UTL-H16B-SF-4B-CV-M25	19300161226
2M25	UTL-H16B-SF-4B-CV-2M25	19300161266
PG21	UTL-H16B-SF-4B-CV-PG21	09300161220
2PG21	UTL-H16B-SF-4B-CV-2PG21	09300161260
带金属盖 With metal cover		
M25	UTL-H16B-SF-4B-MCV-M25	19300162226
2M25	UTL-H16B-SF-4B-MCV-2M25	19300162266
PG21	UTL-H16B-SF-4B-MCV-PG21	09300162220
2PG21	UTL-H16B-SF-4B-MCV-2PG21	09300162260

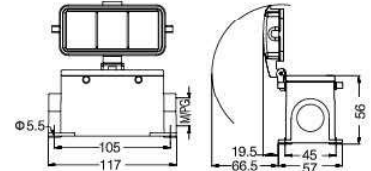

封底下壳 高结构 Housings, surface mounting, high construction



螺纹 Thread	型号 Type	订货号 Part Number
M25	UTL-H16B-SFH-4B-M32	19300160127
M32	UTL-H16B-SFH-4B-2M32	19300160167
M40	UTL-H16B-SFH-4B-PG21	09300160120
PG21	UTL-H16B-SFH-4B-2PG21	09300160160
PG29	UTL-H16B-SFH-4B-PG29	09300160121
2PG29	UTL-H16B-SFH-4B-2PG29	09300160161
带塑料盖 With plastic cover		
M32	UTL-H16B-SFH-4B-CV-M32	19300160227
2M32	UTL-H16B-SFH-4B-CV-2M32	19300160267
PG21	UTL-H16B-SFH-4B-CV-PG21	09300160220
2PG21	UTL-H16B-SFH-4B-CV-2PG21	09300160260
PG29	UTL-H16B-SFH-4B-CV-PG29	09300160221
2PG29	UTL-H16B-SFH-4B-CV-2PG29	09300160261
带金属盖 With metal cover		
M32	UTL-H16B-SFH-4B-MCV-M32	19300160327
2M32	UTL-H16B-SFH-4B-MCV-2M32	19300160367
PG21	UTL-H16B-SFH-4B-MCV-PG21	09300160320
2PG21	UTL-H16B-SFH-4B-MCV-2PG21	09300160360
PG29	UTL-H16B-SFH-4B-MCV-PG29	09300160321
2PG29	UTL-H16B-SFH-4B-MCV-2PG29	09300160361

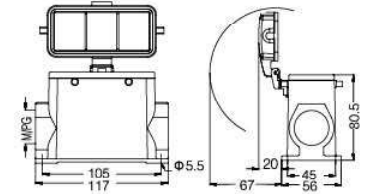

防护盖 Protection covers, metal



接线方式 Connect way	描述 Applications	型号 Type	订货号 Part Number
	金属盖/用于上壳 For hoods	UTL-H16B-MCV-4B/1	09300165426
	金属盖/用于下壳 For housings	UTL-H16B-MCV-4B/2	09300165425

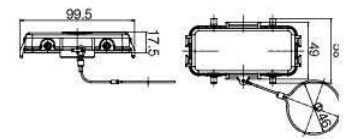

防护盖 Protection covers, metal



接线方式 Connect way	描述 Applications	型号 Type	订货号 Part Number
	金属盖/用于上壳 For hoods	UTL-H16B-MCV-2L.1S	09300165422
	金属盖/用于下壳 For housings	UTL-H16B-MCV-2L.2	09300165423

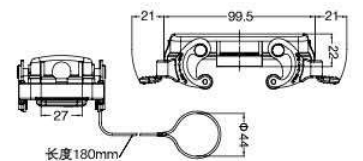



# Metal Hoods & Housings

## 16B 金属外壳

**防护等级 Degree of protection: IP65**

上壳 侧出线 高结构 Hoods, side entry, high construction



螺纹 Thread	型号 Type	订货号 Part Number
M25	UTL-H16B-SEH-1L/C-M25	19300160586
M32	UTL-H16B-SEH-1L/C-M32	19300160587
PG21	UTL-H16B-SEH-1L/C-PG21	09300160580
PG29	UTL-H16B-SEH-1L/C-PG29	09300160581

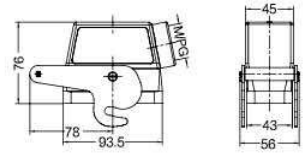

不封底下壳 Housings, bulkhead mounting



螺纹 Thread	型号 Type	订货号 Part Number
---	UTL-H16B-BK-2B/C	09300160381

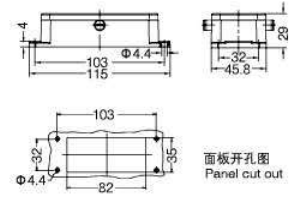

上壳侧出线/顶出线 高结构 Hoods, side&top entry, high construction



型号为:UTL-H16B-SEH/TEH-4B-XX/XX  
如有需要请与我司联系

# Metal Hoods & Housings For higher environmental requirements

## 16B 金属外壳 适用于苛刻环境 (耐腐蚀)

**防护等级 Degree of protection: IP65**

上壳 侧出线 Hoods, side entry



螺纹 Thread	型号 Type	订货号 Part Number
M25	UTL-H16B-MSE-4B-M25	19370161521
PG21	UTL-H16B-MSE-4B-PG21	09370161520

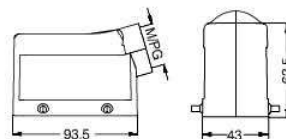

上壳 侧出线 高结构 Hoods, side entry, high construction



螺纹 Thread	型号 Type	订货号 Part Number
M32	UTL-H16B-MSEH-4B-M32	19370160527
M40	UTL-H16B-MSEH-4B-M40	19370160528
PG29	UTL-H16B-MSEH-4B-PG29	09370160521

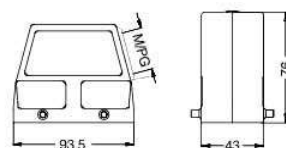

上壳 顶出线 Hoods, top entry



螺纹 Thread	型号 Type	订货号 Part Number
M25	UTL-H16B-MTE-4B-M25	19370161421
PG21	UTL-H16B-MTE-4B-PG21	09370161420

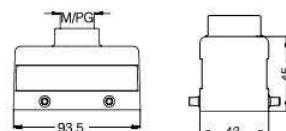

上壳 顶出线 高结构 Hoods, top entry, high construction



螺纹 Thread	型号 Type	订货号 Part Number
M32	UTL-H16B-MTEH-4B-M32	19370160427
PG29	UTL-H16B-MTEH-4B-PG29	09370160421

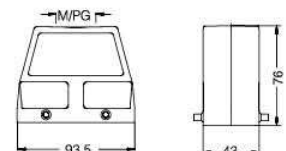

不封底下壳 Housings, bulkhead mounting



螺纹 Thread	型号 Type	订货号 Part Number
---	UTL-H16B-MBK-2L	09370160301

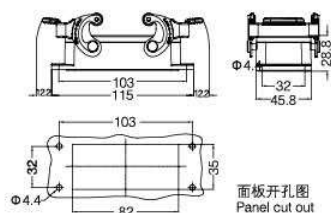

封底下壳 Housings, surface mounting



螺纹 Thread	型号 Type	订货号 Part Number
M25	UTL-H16B-MSF-2L-M25	19370161231
PG21	UTL-H16B-MSF-2L-PG21	09370161230

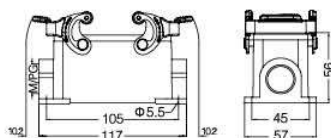

# Metal Hoods & Housings For higher environmental requirements

## 16B 金属外壳 适用于苛刻环境 (耐腐蚀)

### 防护等级 Degree of protection: IP65

封底下壳 高结构 Housings, surface mounting, high construction



螺纹 Thread	型号 Type	订货号 Part Number
2M32	UTL-H16B-MSFH-2L-2M32	19370160272
2M40	UTL-H16B-MSFH-2L-2M40	19370160273
2PG29	UTL-H16B-MSFH-2L-2PG29	09370160271

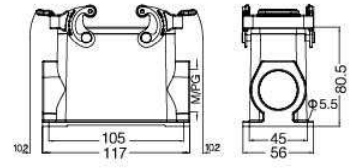

飞线下壳 Housings, cable to cable



螺纹 Thread	型号 Type	订货号 Part Number
PG21	UTL-H16B-MCCT-2L-PG21	09370161730

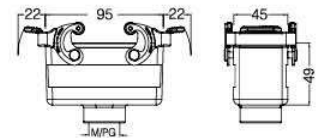

防护盖 Protection covers, metal



接线方式 Connect way	描述 Applications	型号 Type	订货号 Part Number
	金属盖/用于上壳 For hoods	UTL-H16B-MMCV-4B/1	09370165404
	金属盖/用于下壳 For housings	UTL-H16B-MMCV-4B/2	09370165405

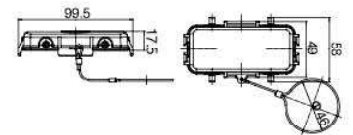

防护盖 Protection covers, metal



接线方式 Connect way	描述 Applications	型号 Type	订货号 Part Number
	金属盖/用于上壳 For hoods	UTL-H16B-MMCV-2L.1S	09370165402
	金属盖/用于下壳 For housings	UTL-H16B-MMCV-2L.2S	09370165403

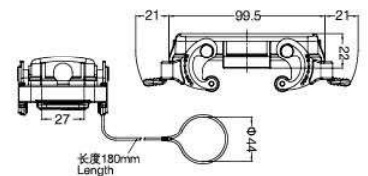

### 防护等级 Degree of protection: IP65

上壳 侧出线 高结构 Hoods, side entry, high construction



螺纹 Thread	型号 Type	订货号 Part Number
M32	UTL-H16B-MSEH-1L-M32	19370160587
PG21	UTL-H16B-MSEH-1L-PG21	09370160587
PG29	UTL-H16B-MSEH-1L-PG29	09370160588

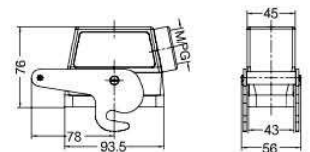

不封底下壳 Housings, bulkhead mounting



螺纹 Thread	型号 Type	订货号 Part Number
---	UTL-H16B-MBK-2B/C	09370160381

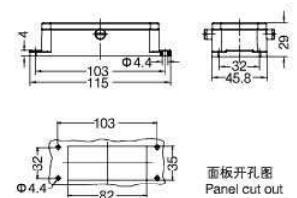

# Hoods & Housings For Harsh Environmental Requirements

## 16B 高防护外壳

**防护等级 Degree of protection: IP65**

上壳 侧出线 高结构 Hoods, side entry, high construction



螺纹 Thread	型号 Type	订货号 Part Number
M25	UTL-HP16B-SEH-2S-M25	19400160211
M32	UTL-HP16B-SEH-2S-M32	19400160212
M40	UTL-HP16B-SEH-2S-M40	19400160213
PG21	UTL-HP16B-SEH-2S-PG21	09400160212
PG29	UTL-HP16B-SEH-2S-PG29	09400160213

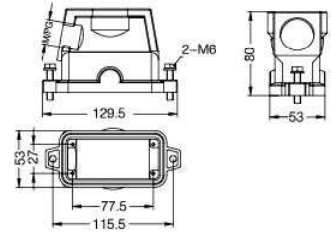

上壳 顶出线 高结构 Hoods, top entry, high construction



螺纹 Thread	型号 Type	订货号 Part Number
M25	UTL-HP16B-TEH-2S-M25	19400160221
M32	UTL-HP16B-TEH-2S-M32	19400160222
M40	UTL-HP16B-TEH-2S-M40	19400160223
M50	UTL-HP16B-TEH-2S-M50	19400160224
PG21	UTL-HP16B-TEH-2S-PG21	09400160222
PG29	UTL-HP16B-TEH-2S-PG29	09400160223

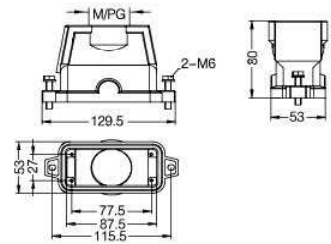

封底下壳 Housings, surface mounting



螺纹 Thread	型号 Type	订货号 Part Number
M25	UTL-HP16B-SFH-2H-M25	19400160231
M32	UTL-HP16B-SFH-2H-M32	19400160232
M40	UTL-HP16B-SFH-2H-M40	19400160233
PG21	UTL-HP16B-SFH-2H-PG21	09400160232
PG29	UTL-HP16B-SFH-2H-PG29	09400160233

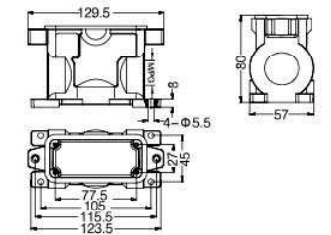

不封底下壳 Housings, bulkhead mounting



螺纹 Thread	型号 Type	订货号 Part Number
---	UTL-HP16B-BK-2H	09400160201

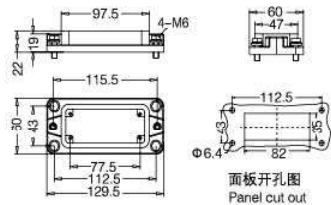

# Hoods & Housings For Harsh Environmental Requirements

## 16B 高防护外壳

### 防护等级 Degree of protection: IP65

上壳 侧出线 高结构 Hoods, side entry, high construction



螺纹 Thread	型号 Type	订货号 Part Number
螺栓联锁 Screw locking		
M25	UTL-HP16B/H-SEH-2S-M25	19400160511
M32	UTL-HP16B/H-SEH-2S-M32	19400160512
M40	UTL-HP16B/H-SEH-2S-M40	19400160513
M50	UTL-HP16B/H-SEH-2S-M50	19400160514
PG21	UTL-HP16B/H-SEH-2S-PG21	09400160512
PG29	UTL-HP16B/H-SEH-2S-PG29	09400160513
PG36	UTL-HP16B/H-SEH-2S-PG36	09400160514
轴销联锁 Toggle locking		
M25	UTL-HP16B/H-SEH-2T-M25	19400160501
M32	UTL-HP16B/H-SEH-2T-M32	19400160502
M40	UTL-HP16B/H-SEH-2T-M40	19400160503
PG21	UTL-HP16B/H-SEH-2T-PG21	09400160502
PG29	UTL-HP16B/H-SEH-2T-PG29	09400160503
PG36	UTL-HP16B/H-SEH-2T-PG36	09400160504

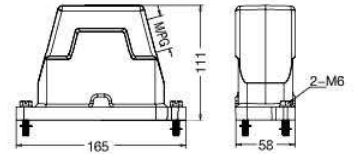

上壳 顶出线 高结构 Hoods, top entry, high construction



螺纹 Thread	型号 Type	订货号 Part Number
螺栓联锁 Screw locking		
M25	UTL-HP16B/H-TEH-2S-M25	19400160411
M32	UTL-HP16B/H-TEH-2S-M32	19400160412
M40	UTL-HP16B/H-TEH-2S-M40	19400160413
M50	UTL-HP16B/H-TEH-2S-M50	19400160414
PG21	UTL-HP16B/H-TEH-2S-PG21	09400160412
PG29	UTL-HP16B/H-TEH-2S-PG29	09400160413
PG36	UTL-HP16B/H-TEH-2S-PG36	09400160414
轴销联锁 Toggle locking		
M25	UTL-HP16B/H-TEH-2T-M25	19400160401
M32	UTL-HP16B/H-TEH-2T-M32	19400160402
M40	UTL-HP16B/H-TEH-2T-M40	19400160403
M50	UTL-HP16B/H-TEH-2T-M50	19400160404
PG21	UTL-HP16B/H-TEH-2T-PG21	09400160402
PG29	UTL-HP16B/H-TEH-2T-PG29	09400160403
PG36	UTL-HP16B/H-TEH-2T-PG36	09400160404

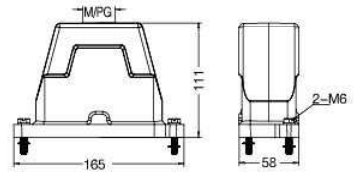

封底下壳 高结构 Housings, surface mounting, high construction



螺纹 Thread	型号 Type	订货号 Part Number
螺栓联锁 Screw locking		
M25	UTL-HP16B/H-SFH-2H-M25	19400161261
M32	UTL-HP16B/H-SFH-2H-M32	19400161262
M40	UTL-HP16B/H-SFH-2H-M40	19400161263
PG21	UTL-HP16B/H-SFH-2H-PG21	09400161261
PG29	UTL-HP16B/H-SFH-2H-PG29	09400161262
PG36	UTL-HP16B/H-SFH-2H-PG36	09400161263
轴销联锁 Toggle locking		
M25	UTL-HP16B/H-SFH-2T-M25	19400161281
M32	UTL-HP16B/H-SFH-2T-M32	19400161282
M40	UTL-HP16B/H-SFH-2T-M40	19400161283
PG21	UTL-HP16B/H-SFH-2T-PG21	09400161282
PG29	UTL-HP16B/H-SFH-2T-PG29	09400161283

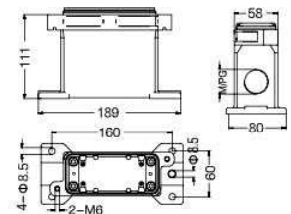

# Hoods & Housings For Harsh Environmental Requirements

## 16B 高防护外壳

防护等级 Degree of protection: IP65

不封底下壳 Housings, bulkhead mounting



螺纹 Thread	型号 Type	订货号 Part Number
	螺栓联锁 Screw locking	
---	UTL-HP16B/H-BK-2H	09400160311
	轴销联锁 Toggle locking	
---	UTL-HP16B/H-BK-2T	09400160301
	带金属盖 With metal cover	
	螺栓联锁 Screw locking	
---	UTL-HP16B/H-BK-2H-MCV	09400160317
	轴销联锁 Toggle locking	
---	UTL-HP16B/H-BK-2T-MCV	09400160307

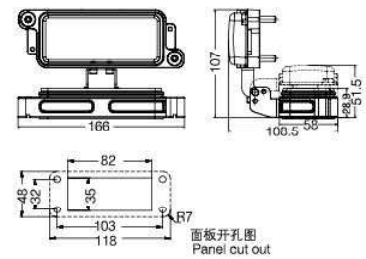

防护盖 Protection covers, metal



螺纹 Thread	型号 Type	订货号 Part Number
	螺栓联锁 Screw locking	
---	UTL-HP16B/H-MCV-2S	09400165411
	轴销联锁 Toggle locking	
---	UTL-HP16B/H-MCV-2T	09400165401

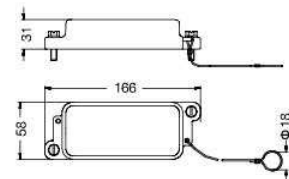

上壳 侧出线 高结构 Hoods, side entry, high construction



螺纹 Thread	型号 Type	订货号 Part Number
M25	UTL-HP16B/H-SEH-4S-M25	19400161361
M32	UTL-HP16B/H-SEH-4S-M32	19400161362
M40	UTL-HP16B/H-SEH-4S-M40	19400161363
PG21	UTL-HP16B/H-SEH-4S-PG21	09400161362
PG29	UTL-HP16B/H-SEH-4S-PG29	09400161363

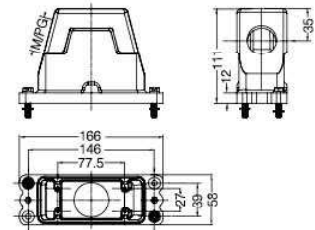

上壳 顶出线 高结构 Hoods, top entry, high construction



螺纹 Thread	型号 Type	订货号 Part Number
M25	UTL-HP16B/H-TEH-4S-M25	19400161461
M32	UTL-HP16B/H-TEH-4S-M32	19400161462
M40	UTL-HP16B/H-TEH-4S-M40	19400161463
M50	UTL-HP16B/H-TEH-4S-M50	19400161464
PG21	UTL-HP16B/H-TEH-4S-PG21	09400161461
PG29	UTL-HP16B/H-TEH-4S-PG29	09400161462
PG36	UTL-HP16B/H-TEH-4S-PG36	09400161463

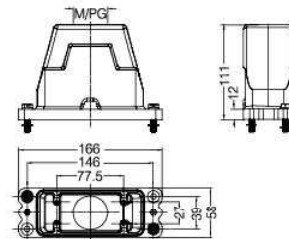

不封底下壳 Housings, bulkhead mounting



螺纹 Thread	型号 Type	订货号 Part Number
---	UTL-HP16B/H-BK-4H	09400160202

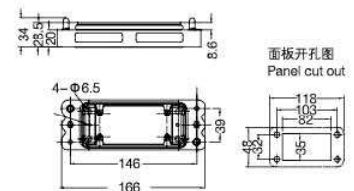

# Hoods & Housings For Harsh Environmental Requirements

## 16B 高防护外壳

### 防护等级 Degree of protection: IP65

上壳 顶出线 高结构 Hoods, top entry, high construction EMC version



螺纹 Thread	型号 Type	订货号 Part Number
M32	UTL-EMC · H16B-TEH-4S-M32	19620160442
M40	UTL-EMC · H16B-TEH-4S-M40	19620160443
PG21	UTL-EMC · H16B-TEH-4S-PG21	09620160540
PG29	UTL-EMC · H16B-TEH-4S-PG29	09620160541

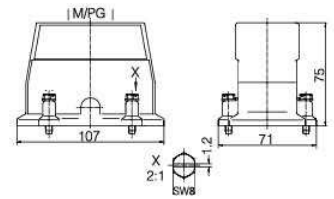

不封底下壳 Housings, bulkhead mounting EMC version



螺纹 Thread	型号 Type	订货号 Part Number
---	UTL-EMC · H16B-BK-4H	09620160301

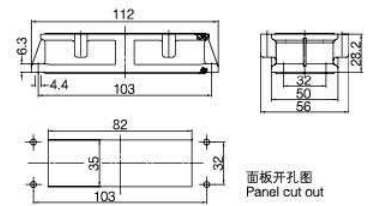

整体型外壳 侧出线 高结构 Hoods, side entry, high construction



螺纹 Thread	型号 Type	订货号 Part Number
M25	UTL-HC16B-SEH-2S-M32	19400161501
M32	UTL-HC16B-SEH-2S-M40	19400161502
PG21	UTL-HC16B-SEH-2S-PG21	09400161501
PG29	UTL-HC16B-SEH-2S-PG29	09400161502

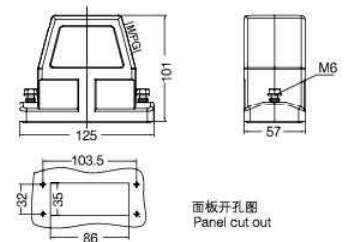

整体型外壳 顶出线 高结构 Hoods, top entry, high construction



螺纹 Thread	型号 Type	订货号 Part Number
M32	UTL-HC16B-TEH-2S-M32	19400161551
M40	UTL-HC16B-TEH-2S-M40	19400161552
PG21	UTL-HC16B-TEH-2S-PG21	09400161551
PG29	UTL-HC16B-TEH-2S-PG29	09400161552

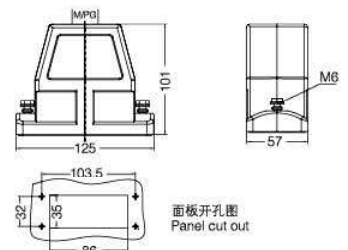

芯体安装支块 Mounting frames



螺纹 Thread	型号 Type	订货号 Part Number
---	UTL-APT-C	09400161600

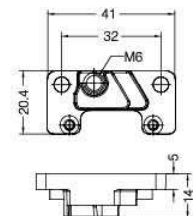

# Metal Hoods & Housings For HighVoltage Inserts(HVE Series)

## UTL-HV16B 金属外壳 适用高压插芯 (HVE 系列)

**防护等级 Degree of protection: IP65**

上壳 侧出线 Hoods, side entry



螺纹 Thread	型号 Type	订货号 Part Number
M25	UTL-HV16B-SE-2B-M25	19340161541
M32	UTL-HV16B-SE-2B-M32	19340161542
PG21	UTL-HV16B-SE-2B-PG21	09340161540

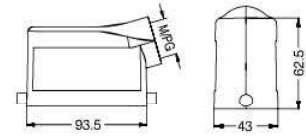

上壳 侧出线 高结构 Hoods, side entry,high construction



螺纹 Thread	型号 Type	订货号 Part Number
M32	UTL-HV16B-SEH-2B-M32	19340160547
M40	UTL-HV16B-SEH-2B-M40	19340160548
PG21	UTL-HV16B-SEH-2B-PG21	09340160540
PG29	UTL-HV16B-SEH-2B-PG29	09340160541

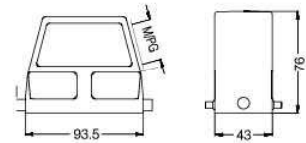

上壳 顶出线 Hoods, top entry



螺纹 Thread	型号 Type	订货号 Part Number
M25	UTL-HV16B-TE-2B-M25	19340161441
M32	UTL-HV16B-TE-2B-M32	19340161442
PG21	UTL-HV16B-TE-2B-PG21	09340161440

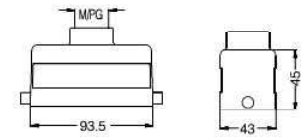

上壳 顶出线 高结构 Hoods, top entry, high construction



螺纹 Thread	型号 Type	订货号 Part Number
M32	UTL-HV16B-TEH-2B-M32	19340160447
M40	UTL-HV16B-TEH-2B-M40	19340160448
PG21	UTL-HV16B-TEH-2B-PG21	09340160440
PG29	UTL-HV16B-TEH-2B-PG29	09340160441

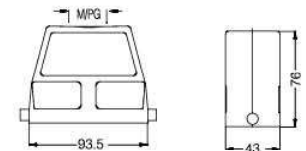

飞线下壳 Housings, cable to cable



螺纹 Thread	型号 Type	订货号 Part Number
M25	UTL-HV16B-CCT-1-M25	19340161751
M32	UTL-HV16B-CCT-1-M32	19340161752
PG21	UTL-HV16B-CCT-1L-PG21	09340161750

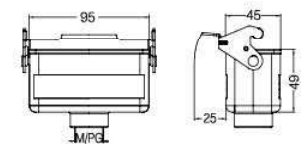

飞线下壳 高结构 Housings, cable to cable, high construction



螺纹 Thread	型号 Type	订货号 Part Number
M25	UTL-HV16B-CCTH-1L-M32	19340160757
M40	UTL-HV16B-CCTH-1L-M40	19340160758
PG21	UTL-HV16B-CCTH-1L-PG21	09340160750
PG29	UTL-HV16B-CCTH-1L-PG29	09340160751

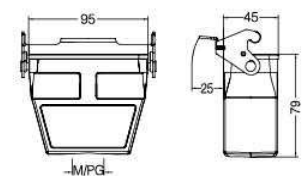



# Metal Hoods & Housings For High Voltage Inserts(HVE Series)

## UTL-HV16B 金属外壳 适用高压插芯 (HVE 系列)

**防护等级 Degree of protection: IP65**

不封底下壳 Housings, bulkhead mounting



螺纹 Thread	型号 Type	订货号 Part Number
---	UTL-HV16B-BK-1L	09340160307
	带塑料盖 With Plastic Cover	
---	UTL-HV16B-BK-1L-CV	09340160306
	带金属盖 With Metal Cover	
---	UTL-HV16B-BK-1L-MCV	09340160318

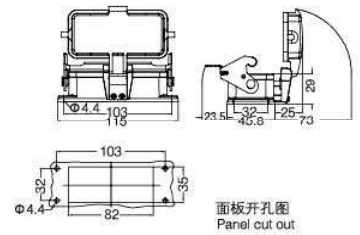

封底下壳 Housings, surface mounting



螺纹 Thread	型号 Type	订货号 Part Number
M25	UTL-HV16B-SF-1L-M25	19340161251
2M25	UTL-HV16B-SF-1L-2M25	19340161291
PG21	UTL-HV16B-SF-1L-PG21	09340161250
2PG21	UTL-HV16B-SF-1L-2PG21	09340161290
	带塑料盖 With Plastic Cover	
M25	UTL-HV16B-SF-1L-CV-M25	19340161256
2M25	UTL-HV16B-SF-1L-CV-2M25	19340161296
PG21	UTL-HV16B-SF-1L-CV-PG21	09340161255
2PG21	UTL-HV16B-SF-1L-CV-2PG21	09340161295
	带金属盖 With Metal Cover	
M25	UTL-HV16B-SF-1L-MCV-M25	19340162256
2M25	UTL-HV16B-SF-1L-MCV-2M25	19340162296
PG21	UTL-HV16B-SF-1L-MCV-PG21	09340162255
2PG21	UTL-HV16B-SF-1L-MCV-2PG21	09340162295

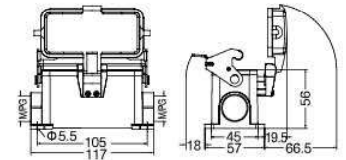

封底下壳 高结构 Housings, surface mounting, high construction



螺纹 Thread	型号 Type	订货号 Part Number
M32	UTL-HV16B-SFH-1L-M32	19340160252
2M25	UTL-HV16B-SFH-1L-2M25	19340160291
2M32	UTL-HV16B-SFH-1L-2M32	19340160292
PG21	UTL-HV16B-SFH-1L-PG21	09340160250
2PG21	UTL-HV16B-SFH-1L-2PG21	09340160290
PG29	UTL-HV16B-SFH-1L-PG29	09340160251
2PG29	UTL-HV16B-SFH-1L-2PG29	09340160291
	带塑料盖 With Plastic Cover	
M32	UTL-HV16B-SFH-1L-CV-M32	19340160257
2M32	UTL-HV16B-SFH-1L-CV-2M32	19340160297
PG21	UTL-HV16B-SFH-1L-CV-PG21	09340160255
2PG21	UTL-HV16B-SFH-1L-CV-2PG21	09340160295
PG29	UTL-HV16B-SFH-1L-CV-PG29	09340160256
2PG29	UTL-HV16B-SFH-1L-CV-2PG29	09340160296
	带金属盖 With Metal Cover	
M32	UTL-HV16B-SFH-1L-MCV-M32	19340167257
2M32	UTL-HV16B-SFH-1L-MCV-2M32	19340167297
PG21	UTL-HV16B-SFH-1L-MCV-PG21	09340162257
2PG21	UTL-HV16B-SFH-1L-MCV-2PG21	09340162297
PG29	UTL-HV16B-SFH-1L-MCV-PG29	09340162258
2PG29	UTL-HV16B-SFH-1L-MCV-2PG29	09340162298

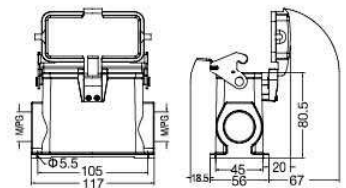

# Metal Hoods & Housings For HighVoltage Inserts(HVE Series)

## UTL-HV16B 金属外壳 适用高压插芯 (HVE 系列)

**防护等级 Degree of protection: IP65**

上壳 侧出线 Hoods, side entry



螺纹 Thread	型号 Type	订货号 Part Number
M25	UTL-HV16B-SE-4B-M25	19340160521
M32	UTL-HV16B-SE-4B-M32	19340160522
PG21	UTL-HV16B-SE-4B-PG21	09340160522

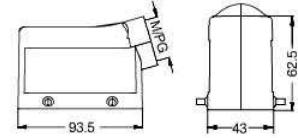

上壳 侧出线 高结构 Hoods, side entry,high construction



螺纹 Thread	型号 Type	订货号 Part Number
M32	UTL-HV16B-SEH-4B-M32	19340160552
M40	UTL-HV16B-SEH-4B-M40	19340160553
PG21	UTL-HV16B-SEH-4B-PG21	09340160552
PG29	UTL-HV16B-SEH-4B-PG29	09340160553

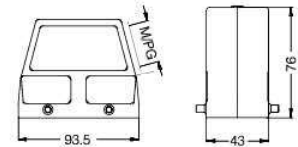

上壳 顶出线 Hoods, top entry



螺纹 Thread	型号 Type	订货号 Part Number
M25	UTL-HV16B-TE-4B-M25	19340160421
PG21	UTL-HV16B-TE-4B-PG21	19340160422

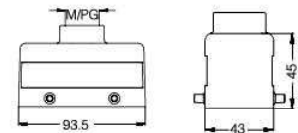

上壳 顶出线 高结构 Hoods, top entry, high construction



螺纹 Thread	型号 Type	订货号 Part Number
M32	UTL-HV16B-TEH-4B-M32	19340160452
M40	UTL-HV16B-TEH-4B-M40	19340160453
PG21	UTL-HV16B-TEH-4B-PG21	09340160452
PG29	UTL-HV16B-TEH-4B-PG29	09340160453

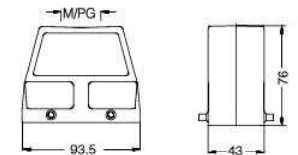

不封底下壳 Housings, bulkhead mounting



螺纹 Thread	型号 Type	订货号 Part Number
---	UTL-HV16B-BK-2L	09340160301

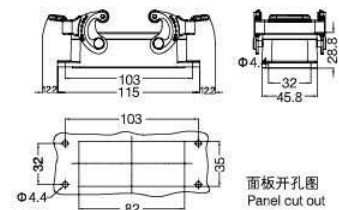

封底下壳 Housings, surface mounting



螺纹 Thread	型号 Type	订货号 Part Number
M25	UTL-HV16B-SF-2L-M25	19340160271
2M25	UTL-HV16B-SF-2L-2M25	19340160275
PG21	UTL-HV16B-SF-2L-PG21	09340160272
2PG21	UTL-HV16B-SF-2L-2PG21	09340160276

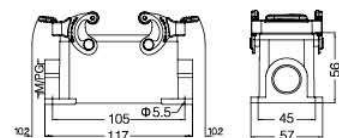

# Metal Hoods & Housings For High Voltage Inserts(HVE Series)

## UTL-HV16B 金属外壳 适用高压插芯 (HVE 系列)

**防护等级 Degree of protection: IP65**

封底下壳 高结构 Housings, surface mounting, high construction



螺纹 Thread	型号 Type	订货号 Part Number
M32	UTL-HV16B-SFH-2L-M32	19340160232
2M32	UTL-HV16B-SFH-2L-2M32	19340160272
PG21	UTL-HV16B-SFH-2L-PG21	09340160230
2PG21	UTL-HV16B-SFH-2L-2PG21	09340160270
PG29	UTL-HV16B-SFH-2L-PG29	09340160231
2PG29	UTL-HV16B-SFH-2L-2PG29	09340160271

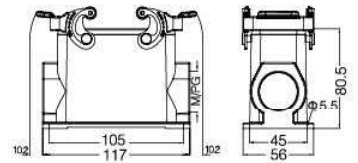

飞线下壳 Housings, cable to cable



螺纹 Thread	型号 Type	订货号 Part Number
M25	UTL-HV16B-CCT-2L-M25	19340160731
M32	UTL-HV16B-CCT-2L-M32	19340160732
PG21	UTL-HV16B-CCT-2L-PG21	09340160732

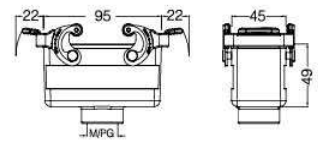

飞线下壳 高结构 Housings, cable to cable, high construction



螺纹 Thread	型号 Type	订货号 Part Number
M32	UTL-HV16B-CCTH-2L-M32	19340160737
M40	UTL-HV16B-CCTH-2L-M40	19340160738
PG21	UTL-HV16B-CCTH-2L-PG21	09340160730
PG29	UTL-HV16B-CCTH-2L-PG29	09340160731

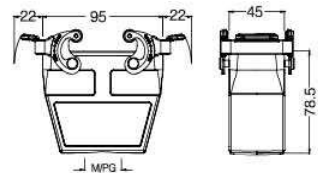

塑料防护盖 4卡扣 Protection covers, plastic



接线方式 Connect way	描述 Applications	型号 Type	订货号 Part Number
---	用于上壳 For hoods	UTL-H16B-CV-4C	09300165401

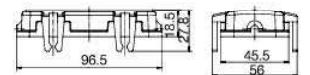

塑料防护盖 Protection covers, plastic



接线方式 Connect way	描述 Applications	型号 Type	订货号 Part Number
○	塑料盖/用于飞线下壳 For Housings, cable to cable	UTL-H16B-CV-4B/1	09300165427
●	塑料盖/用于不封底,封底下壳 For housing, bulkhead/ surface mounting	UTL-H16B-CV-4B/2	09300165428

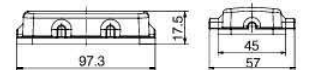

# Metal Hoods & Housings For HighVoltage Inserts(HVE Series)

## UTL-HV16B 金属外壳 适用高压插芯 (HVE 系列)

**防护等级 Degree of protection: IP65**

上壳 侧出线 Hoods, side entry



螺纹 Thread	型号 Type	订货号 Part Number
M25	UTL-HV16B-SE-2L-M25	19340161531
M32	UTL-HV16B-SE-2L-M32	19340161532
PG21	UTL-HV16B-SE-2L-PG21	09340161530

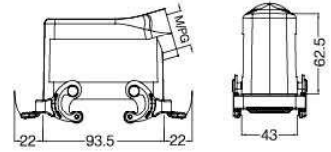

上壳 侧出线 高结构 Hoods, side entry, high construction



螺纹 Thread	型号 Type	订货号 Part Number
M32	UTL-HV16B-SEH-2L-M32	19340160537
M40	UTL-HV16B-SEH-2L-M40	19340160538
PG21	UTL-HV16B-SEH-2L-PG21	09340160530
PG29	UTL-HV16B-SEH-2L-PG29	09340160531

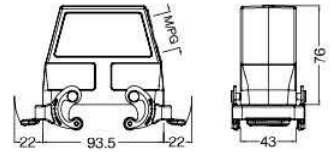

上壳 顶出线 Hoods, top entry



螺纹 Thread	型号 Type	订货号 Part Number
M25	UTL-HV16B-TE-2L-M25	19340161431
M32	UTL-HV16B-TE-2L-M32	19340161432
PG21	UTL-HV16B-TE-2L-PG21	09340161430

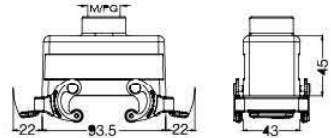

上壳 顶出线 高结构 Hoods, top entry, high construction



螺纹 Thread	型号 Type	订货号 Part Number
M32	UTL-HV16B-TEH-2L-M32	19340160437
M40	UTL-HV16B-TEH-2L-M40	19340160438
PG21	UTL-HV16B-TEH-2L-PG21	09340160430
PG29	UTL-HV16B-TEH-2L-PG29	09340160431

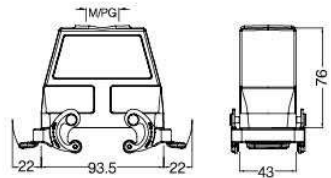

不封底下壳 Housings, bulkhead mounting



螺纹 Thread	型号 Type	订货号 Part Number
---	UTL-HV16B-BK-4B	09340160300
---	带塑料盖with plastic cover	
---	UTL-HV16B-BK-4B-CV	09340160302
---	带金属盖with metal cover	
---	UTL-HV16B-BK-4B-MCV	09340160317

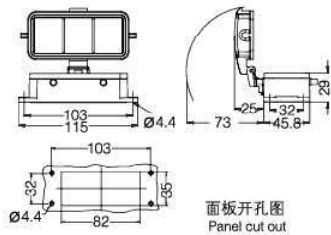

# Metal Hoods & Housings For HighVoltage Inserts(HVE Series) UTL-HV16B 金属外壳 适用高压插芯 (HVE 系列)

**防护等级 Degree of protection: IP65**

封底下壳 Housings, surface mounting



螺纹 Thread	型号 Type	订货号 Part Number
M25	UTL-HV16B-SF-4B-M25	19340161126
2M25	UTL-HV16B-SF-4B-2M25	19340161166
PG21	UTL-HV16B-SF-4B-PG21	09340161120
2PG21	UTL-HV16B-SF-4B-2PG21	09340161160
带塑料盖 With Plastic Cover		
M25	UTL-HV16B-SF-4B-CV-M25	19340161226
2M25	UTL-HV16B-SF-4B-CV-2M25	19340161266
PG21	UTL-HV16B-SF-4B-CV-PG21	09340161220
2PG21	UTL-HV16B-SF-4B-CV-2PG21	09340161260
带金属盖 With Metal Cover		
M25	UTL-HV16B-SF-4B-MCV-M25	19340162226
2M25	UTL-HV16B-SF-4B-MCV-2M25	19340162266
PG21	UTL-HV16B-SF-4B-MCV-PG21	09340162220
2PG21	UTL-HV16B-SF-4B-MCV-2PG21	09340162260

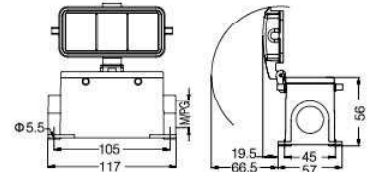

封底下壳 高结构 Housings, surface mounting, high construction



螺纹 Thread	型号 Type	订货号 Part Number
M32	UTL-HV16B-SFH-4B-M32	19340160127
2M32	UTL-HV16B-SFH-4B-2M32	19340160167
PG21	UTL-HV16B-SFH-4B-PG21	09340160120
2PG21	UTL-HV16B-SFH-4B-2PG21	09340160160
PG29	UTL-HV16B-SFH-4B-PG29	09340160121
2PG29	UTL-HV16B-SFH-4B-2PG29	09340160161
带塑料盖 With Plastic Cover		
M32	UTL-HV16B-SFH-4B-CV-M32	19340160227
2M32	UTL-HV16B-SFH-4B-CV-2M32	19340160267
PG21	UTL-HV16B-SFH-4B-CV-PG21	09340160220
2PG21	UTL-HV16B-SFH-4B-CV-2PG21	09340160260
PG29	UTL-HV16B-SFH-4B-CV-PG29	09340160221
2PG29	UTL-HV16B-SFH-4B-CV-2PG29	09340160261
带金属盖 With Metal Cover		
M32	UTL-HV16B-SFH-4B-MCV-M32	19340160327
2M32	UTL-HV16B-SFH-4B-MCV-2M32	19340160367
PG21	UTL-HV16B-SFH-4B-MCV-PG21	09340160320
2PG21	UTL-HV16B-SFH-4B-MCV-2PG21	09340160360
PG29	UTL-HV16B-SFH-4B-MCV-PG29	09340160321
2PG29	UTL-HV16B-SFH-4B-MCV-2PG29	09340160361

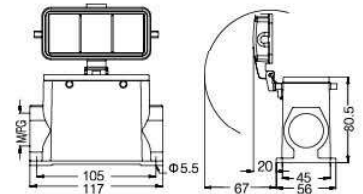

防护盖 Protection covers, metal



接线方式 Connect way	描述 Applications	型号 Type	订货号 Part Number
	金属保护盖/用于上壳 For hoods	H16B-MCV-4B/1	09340165426
	金属保护盖/用于下壳 For housings	H16B-MCV-4B/2	09340165425

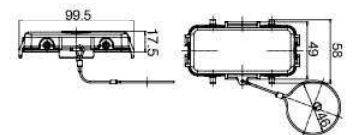

防护盖 Protection covers, metal



接线方式 Connect way	描述 Applications	型号 Type	订货号 Part Number
	金属保护盖/用于上壳 For hoods	H16B-MCV-2L.1S	09340165422
	金属保护盖/用于下壳 For housings	H16B-MCV-2L.2S	09340165423

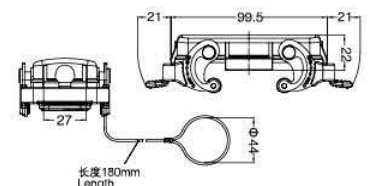

# Metal Hoods & Housings For High Voltage Inserts(HVE Series)

## UTL-HV16B 金属外壳 适用高压插芯 (HVE 系列)

**防护等级 Degree of protection: IP65**

上壳 侧出线 高结构 Hoods, side entry, high construction



螺纹 Thread	型号 Type	订货号 Part Number
M32	UTL-HV16B-SEH-1L/C-M32	19340160587
PG21	UTL-HV16B-SEH-1L/C-PG21	09340160580
PG29	UTL-HV16B-SEH-1L/C-PG29	09340160581

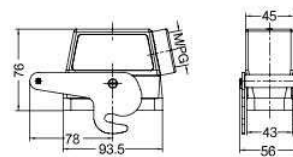

不封底下壳 Housings, bulkhead mounting



螺纹 Thread	型号 Type	订货号 Part Number
---	UTL-HV16B-BK-2B/C	09340160381

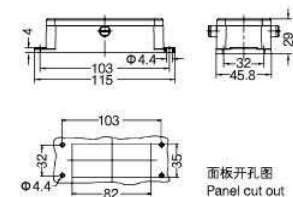

# Plastic Hoods & Housings

## 24B 塑料外壳

### 防护等级 Degree of protection: IP65

上壳 侧出线 高结构 Hoods, side entry, high construction



螺纹 Thread	型号 Type	订货号 Part Number
M32	UTL-H24B.P-SEH-4B-M32	19300240111
M40	UTL-H24B.P-SEH-4B-M40	19300240112

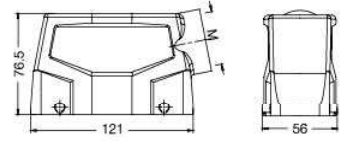

上壳 顶出线 高结构 Hoods, top entry, high construction



螺纹 Thread	型号 Type	订货号 Part Number
M32	UTL-H24B.P-TEH-4B-M32	19300240121
M40	UTL-H24B.P-TEH-4B-M40	19300240122

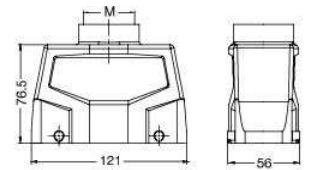

不封底下壳 Housings, bulkhead mounting



螺纹 Thread	型号 Type	订货号 Part Number
---	UTL-H24B.P-BK-2L	09300240300

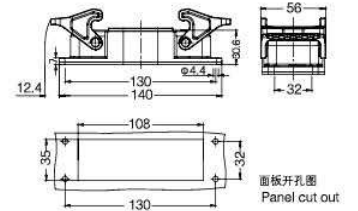

封底下壳 高结构 Housings, surface mounting, high construction



螺纹 Thread	型号 Type	订货号 Part Number
M32	UTL-H24B.P-SFH-2L-M32	19300240131
2M32	UTL-H24B.P-SFH-2L-2M32	19300240135
M40	UTL-H24B.P-SFH-2L-M40	19300240132
2M40	UTL-H24B.P-SFH-2L-2M40	19300240136

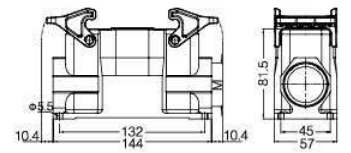

防护盖 Protection covers, metal



螺纹 Thread	型号 Type	订货号 Part Number
---	UTL-H24B.P-CV-4B/2	09300240140

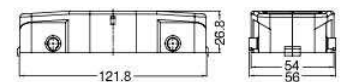

防护盖 Protection covers, metal



螺纹 Thread	型号 Type	订货号 Part Number
---	UTL-H24B.P-CV-2L/1	09300240145

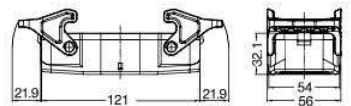

# Metal Hoods & Housings

## 24B 金属外壳

**防护等级 Degree of protection: IP65**

上壳 侧出线 Hoods, side entry



螺纹 Thread	型号 Type	订货号 Part Number
M25	UTL-H24B-SE-2B-M25	19300241541
M32	UTL-H24B-SE-2B-M32	19300241542
PG21	UTL-H24B-SE-2B-PG21	09300241540

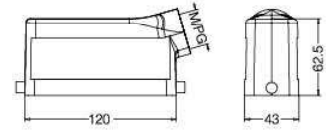

上壳 侧出线 高结构 Hoods, side entry, high construction



螺纹 Thread	型号 Type	订货号 Part Number
M25	UTL-H24B-SEH-2B-M25	19300240546
M32	UTL-H24B-SEH-2B-M32	19300240547
M40	UTL-H24B-SEH-2B-M40	19300240548
PG21	UTL-H24B-SEH-2B-PG21	09300240540
PG29	UTL-H24B-SEH-2B-PG29	09300240541
PG36	UTL-H24B-SEH-2B-PG36	09300240546

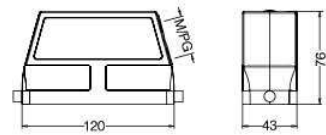

上壳 顶出线 Hoods, top entry



螺纹 Thread	型号 Type	订货号 Part Number
M25	UTL-H24B-TE-2B-M25	19300241441
M32	UTL-H24B-TE-2B-M32	19300241442
PG21	UTL-H24B-TE-2B-PG21	09300241440
PG29	UTL-H24B-TE-2B-PG29	09300241441

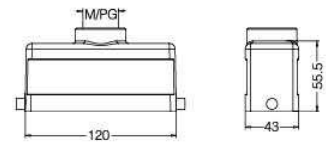

上壳 顶出线 高结构 Hoods, top entry, high construction



螺纹 Thread	型号 Type	订货号 Part Number
M32	UTL-H24B-TEH-2B-M32	19300240447
M40	UTL-H24B-TEH-2B-M40	19300240448
PG21	UTL-H24B-TEH-2B-PG21	09300240440
PG29	UTL-H24B-TEH-2B-PG29	09300240441
PG36	UTL-H24B-TEH-2B-PG36	09300240446

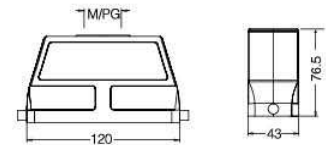

飞线下壳 Housings, cable to cable



螺纹 Thread	型号 Type	订货号 Part Number
M25	UTL-H24B-CCT-1L-M25	19300241751
M32	UTL-H24B-CCT-1L-M32	19300241752
PG21	UTL-H24B-CCT-1L-PG21	09300241750
PG29	UTL-H24B-CCT-1L-PG29	09300241751

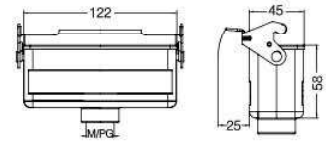

飞线下壳 高结构 Housings, cable to cable, high construction



螺纹 Thread	型号 Type	订货号 Part Number
M32	UTL-H24B-CCTH-1L-M32	19300240757
M40	UTL-H24B-CCTH-1L-M40	19300240758
PG21	UTL-H24B-CCTH-1L-PG21	09300240750
PG29	UTL-H24B-CCTH-1L-PG29	09300240751

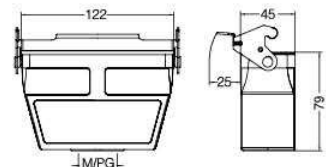



# Metal Hoods & Housings

## 24B 金属外壳

防护等级 Degree of protection: IP65

不封底下壳 Housings, bulkhead mounting



螺纹 Thread	型号 Type	订货号 Part Number
---	UTL-H24B-BK-1L	09300240307
	带塑料盖 With Plastic Cover	
---	UTL-H24B-BK-1L-CV	09300240304
	带金属盖 With Metal Cover	
---	UTL-H24B-BK-1L-MCV	09300240318

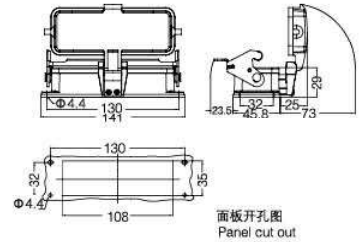

封底下壳 Housings, surface mounting



螺纹 Thread	型号 Type	订货号 Part Number
M25	UTL-H24B-SF-1L-M25	19300241251
2M25	UTL-H24B-SF-1L-2M25	19300241291
PG21	UTL-H24B-SF-1L-PG21	09300241250
2PG21	UTL-H24B-SF-1L-2PG21	09300241290
	带塑料盖 With Plastic Cover	
M25	UTL-H24B-SF-1L-CV-M25	19300241256
2M25	UTL-H24B-SF-1L-CV-2M25	19300241296
PG21	UTL-H24B-SF-1L-CV-PG21	09300241255
2PG21	UTL-H24B-SF-1L-CV-2PG21	09300241295
	带金属盖 With Metal Cover	
M25	UTL-H24B-SF-1L-MCV-M25	19300242256
2M25	UTL-H24B-SF-1L-MCV-2M25	19300242296
PG21	UTL-H24B-SF-1L-MCV-PG21	09300242255
2PG21	UTL-H24B-SF-1L-MCV-2PG21	09300242295

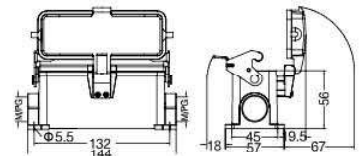

封底下壳 高结构 Housings, surface mounting, high construction



螺纹 Thread	型号 Type	订货号 Part Number
M32	UTL-H24B-SFH-1L-M32	19300240252
2M32	UTL-H24B-SFH-1L-2M32	19300240292
M40	UTL-H24B-SFH-1L-M40	19300240253
2M40	UTL-H24B-SFH-1L-2M40	19300240293
PG21	UTL-H24B-SFH-1L-PG21	09300240250
2PG21	UTL-H24B-SFH-1L-2PG21	09300240290
PG29	UTL-H24B-SFH-1L-PG29	09300240251
2PG29	UTL-H24B-SFH-1L-2PG29	09300240291
	带塑料盖 With Plastic Cover	
M32	UTL-H24B-SFH-1L-CV-M32	19300240257
2M32	UTL-H24B-SFH-1L-CV-2M32	19300240297
PG21	UTL-H24B-SFH-1L-CV-PG21	09300240255
2PG21	UTL-H24B-SFH-1L-CV-2PG21	09300240295
PG29	UTL-H24B-SFH-1L-CV-PG29	09300240256
2PG29	UTL-H24B-SFH-1L-CV-2PG29	09300240296
	带金属盖 With Metal Cover	
M32	UTL-H24B-SFH-1L-MCV-M32	19300247257
2M32	UTL-H24B-SFH-1L-MCV-2M32	19300247297
PG21	UTL-H24B-SFH-1L-MCV-PG21	09300242257
2PG21	UTL-H24B-SFH-1L-MCV-2PG21	09300242297
PG29	UTL-H24B-SFH-1L-MCV-PG29	09300242258
2PG29	UTL-H24B-SFH-1L-MCV-2PG29	09300242298

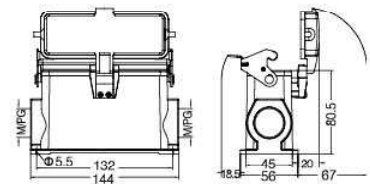

# Metal Hoods & Housings

## 24B 金属外壳

**防护等级 Degree of protection: IP65**

上壳 侧出线 Hoods, side entry



螺纹 Thread	型号 Type	订货号 Part Number
M25	UTL-H24B-SE-4B-M25	19300241521
M32	UTL-H24B-SE-4B-M32	19300241522
PG21	UTL-H24B-SE-4B-PG21	09300241520

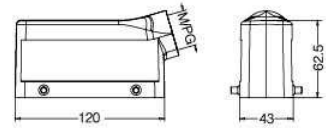

上壳 侧出线 高结构 Hoods, side entry, high construction



螺纹 Thread	型号 Type	订货号 Part Number
M25	UTL-H24B-SEH-4B-M25	19300240526
M32	UTL-H24B-SEH-4B-M32	19300240527
M40	UTL-H24B-SEH-4B-M40	19300240528
PG21	UTL-H24B-SEH-4B-PG21	09300240520
PG29	UTL-H24B-SEH-4B-PG29	09300240521

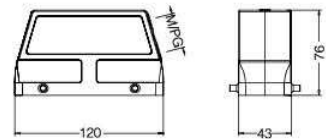

我司可提供顶部、侧面同时出线的非标品, 详见P18-08  
We can provide non-standard products with both top&side entry, see P18-08

上壳 顶出线 Hoods, top entry



螺纹 Thread	型号 Type	订货号 Part Number
M25	UTL-H24B-TE-4B-M25	19300241421
M32	UTL-H24B-TE-4B-M32	19300241422
PG21	UTL-H24B-TE-4B-PG21	09300241420
PG29	UTL-H24B-TE-4B-PG29	09300241421

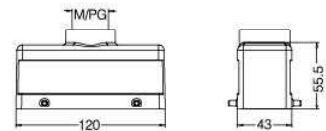

上壳 顶出线 高结构 Hoods, top entry, high construction



螺纹 Thread	型号 Type	订货号 Part Number
M32	UTL-H24B-TEH-4B-M32	19300240427
M40	UTL-H24B-TEH-4B-M40	19300240428
PG21	UTL-H24B-TEH-4B-PG21	09300240420
PG29	UTL-H24B-TEH-4B-PG29	09300240421
2M25	UTL-H24B-TEH-4B-2M25	19300240466
2M32	UTL-H24B-TEH-4B-2M32	19300240467
2PG16	UTL-H24B-TEH-4B-2PG16	09300240461
2PG21	UTL-H24B-TEH-4B-2PG21	09300240462
2PG29	UTL-H24B-TEH-4B-2PG29	09300240463

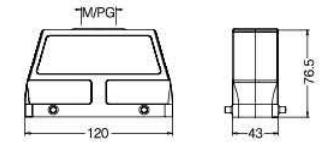

不封底下壳 Housings, bulkhead mounting



螺纹 Thread	型号 Type	订货号 Part Number
---	UTL-H24B-BK-2L	09300240301

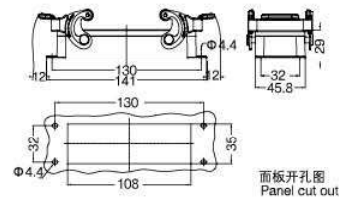

封底下壳 Housings, surface mounting



螺纹 Thread	型号 Type	订货号 Part Number
M25	UTL-H24B-SF-2L-M25	19300241231
2M25	UTL-H24B-SF-2L-2M25	19300241271
PG21	UTL-H24B-SF-2L-PG21	09300241230
2PG21	UTL-H24B-SF-2L-2PG21	09300241270

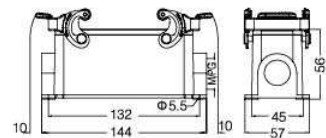

# Metal Hoods & Housings

## 24B 金属外壳

**防护等级 Degree of protection: IP65**

封底下壳 高结构 Housings, surface mounting, high construction



螺纹 Thread	型号 Type	订货号 Part Number
M32	UTL-H24B-SFH-2L-M32	19300240232
2M32	UTL-H24B-SFH-2L-2M32	19300240272
M40	UTL-H24B-SFH-2L-M40	19300240233
2M40	UTL-H24B-SFH-2L-2M40	19300240273
PG21	UTL-H24B-SFH-2L-PG21	09300240230
2PG21	UTL-H24B-SFH-2L-2PG21	09300240270
PG29	UTL-H24B-SFH-2L-PG29	09300240231
2PG29	UTL-H24B-SFH-2L-2PG29	09300240271

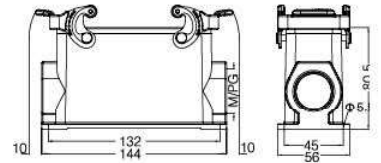

飞线下壳 Housings, cable to cable



螺纹 Thread	型号 Type	订货号 Part Number
M25	UTL-H24B-CCT-2L-M25	19300241731
M32	UTL-H24B-CCT-2L-M32	19300241732
PG21	UTL-H24B-CCT-2L-PG21	09300241730
PG29	UTL-H24B-CCT-2L-PG29	09300241731

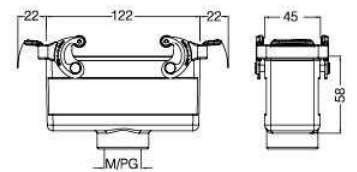

飞线下壳 高结构 Housings, cable to cable, high construction



螺纹 Thread	型号 Type	订货号 Part Number
M32	UTL-H24B-CCTH-2L-M32	19300240737
M40	UTL-H24B-CCTH-2L-M40	19300240738
PG21	UTL-H24B-CCTH-2L-PG21	09300240730
PG29	UTL-H24B-CCTH-2L-PG29	09300240731

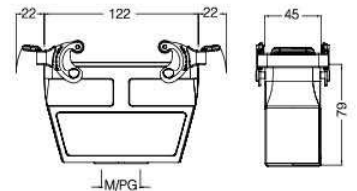

塑料防护盖 4卡扣 Protection covers, plastic



接线方式 Connect way	描述 Applications	型号 Type	订货号 Part Number
---	用于上壳 For hoods	UTL-H24B-CV-4C	09300245401

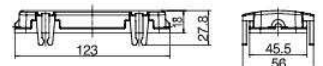

塑料防护盖 Protection covers, plastic



接线方式 Connect way	描述 Applications	型号 Type	订货号 Part Number
	塑料盖/用于飞线下壳 For Housings, cable to cable	UTL-H24B-CV-4B/1	09300245427
	塑料盖/用于不封底,封底下壳 For housing, bulkhead/ surface mounting	UTL-H24B-CV-4B/2	09300245428

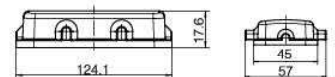

# Metal Hoods & Housings

## 24B 金属外壳

**防护等级 Degree of protection: IP65**

上壳 侧出线 Hoods, side entry



螺纹 Thread	型号 Type	订货号 Part Number
M25	UTL-H24B-SE-2L-M25	19300241531
M32	UTL-H24B-SE-2L-M32	19300241532
PG21	UTL-H24B-SE-2L-PG21	09300241530

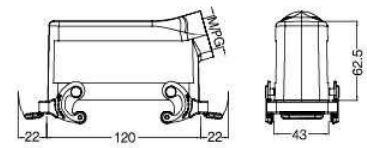

上壳 侧出线 高结构 Hoods, side entry, high construction



螺纹 Thread	型号 Type	订货号 Part Number
M32	UTL-H24B-SEH-2L-M32	19300240537
M40	UTL-H24B-SEH-2L-M40	19300240538
PG21	UTL-H24B-SEH-2L-PG21	09300240530
PG29	UTL-H24B-SEH-2L-PG29	09300240531

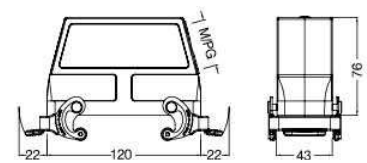

上壳 顶出线 Hoods, top entry



螺纹 Thread	型号 Type	订货号 Part Number
M25	UTL-H24B-TE-2L-M25	19300241431
M32	UTL-H24B-TE-2L-M32	19300241432
PG21	UTL-H24B-TE-2L-PG21	09300241430
PG29	UTL-H24B-TE-2L-PG29	09300241431

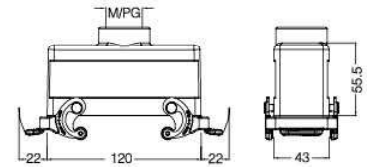

上壳 顶出线 高结构 Hoods, top entry, high construction



螺纹 Thread	型号 Type	订货号 Part Number
M32	UTL-H24B-TEH-2L-M32	19300240437
M40	UTL-H24B-TEH-2L-M40	19300240438
PG21	UTL-H24B-TEH-2L-PG21	09300240430
PG29	UTL-H24B-TEH-2L-PG29	09300240431

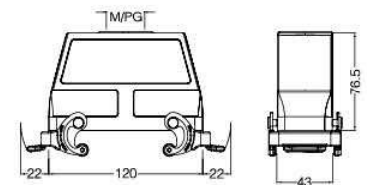

不封底下壳 Housings, bulkhead mounting



螺纹 Thread	型号 Type	订货号 Part Number
---	UTL-H24B-BK-4B	09300240300
---	带塑料盖 With Plastic Cover	
---	UTL-H24B-BK-4B-CV	09300240302
---	带金属盖 With Metal Cover	
---	UTL-H24B-BK-4B-MCV	09300240317

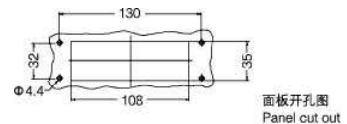
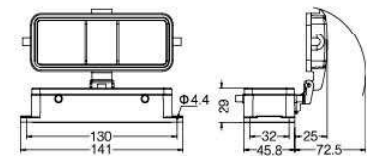

# Metal Hoods & Housings

## 24B 金属外壳

防护等级 Degree of protection: IP65

封底下壳 Housings, surface mounting



螺纹 Thread	型号 Type	订货号 Part Number
M25	UTL-H24B-SF-4B-M25	19300241126
2M25	UTL-H24B-SF-4B-2M25	19300241166
PG21	UTL-H24B-SF-4B-PG21	09300241120
2PG21	UTL-H24B-SF-4B-2PG21	09300241160
带塑料盖 With Plastic Cover		
M25	UTL-H24B-SF-4B-CV-M25	19300241226
2M25	UTL-H24B-SF-4B-CV-2M25	19300241266
PG21	UTL-H24B-SF-4B-CV-PG21	09300241220
2PG21	UTL-H24B-SF-4B-CV-2PG21	09300241260
带金属盖 With Metal Cover		
M25	UTL-H24B-SF-4B-MCV-M25	19300242226
2M25	UTL-H24B-SF-4B-MCV-2M25	19300242266
PG21	UTL-H24B-SF-4B-MCV-PG21	09300242220
2PG21	UTL-H24B-SF-4B-MCV-2PG21	09300242260

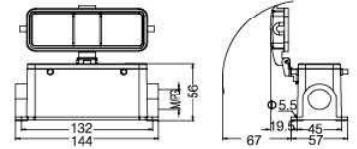

封底下壳 高结构 Housings, surface mounting, high construction



螺纹 Thread	型号 Type	订货号 Part Number
M32	UTL-H24B-SFH-4B-M32	19300240127
2M32	UTL-H24B-SFH-4B-2M32	19300240167
2M40	UTL-H24B-SFH-4B-2M40	19300240168
PG21	UTL-H24B-SFH-4B-PG21	09300240120
2PG21	UTL-H24B-SFH-4B-2PG21	09300240160
PG29	UTL-H24B-SFH-4B-PG29	09300240121
2PG29	UTL-H24B-SFH-4B-2PG29	09300240161
带塑料盖 With Plastic Cover		
M32	UTL-H24B-SFH-4B-CV-M32	19300240227
2M32	UTL-H24B-SFH-4B-CV-2M32	19300240267
2M40	UTL-H24B-SFH-4B-CV-2M40	19300240268
PG21	UTL-H24B-SFH-4B-CV-PG21	09300240220
2PG21	UTL-H24B-SFH-4B-CV-2PG21	09300240260
PG29	UTL-H24B-SFH-4B-CV-PG29	09300240221
2PG29	UTL-H24B-SFH-4B-CV-2PG29	09300240261
带金属盖 With Metal Cover		
M32	UTL-H24B-SFH-4B-MCV-M32	19300242222
2M32	UTL-H24B-SFH-4B-MCV-2M32	19300242262
2M40	UTL-H24B-SFH-4B-MCV-2M40	19300242263
PG21	UTL-H24B-SFH-4B-MCV-PG21	09300242222
2PG21	UTL-H24B-SFH-4B-MCV-2PG21	09300242262
PG29	UTL-H24B-SFH-4B-MCV-PG29	09300242223
2PG29	UTL-H24B-SFH-4B-MCV-2PG29	09300242263

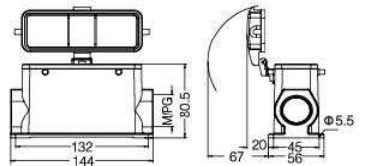

防护盖 Protection covers, metal



接线方式 Connect way	描述 Applications	型号 Type	订货号 Part Number
	防护金属盖/用于上壳 For hoods	UTL-H24B-MCV-4B/1	09300245442
	金属防护盖/用于下壳 For housings	UTL-H24B-MCV-4B/2	09300245443

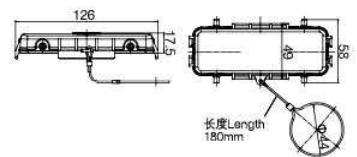

防护盖 Protection covers, metal



接线方式 Connect way	描述 Applications	型号 Type	订货号 Part Number
	防护金属盖/用于上壳 For hoods	UTL-H24B-MCV-2L.1S	09300245422
	金属防护盖/用于下壳 For housings	UTL-H24B-MCV-2L.2S	09300245423

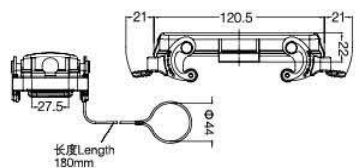

# Metal Hoods & Housings

## 24B 金属外壳

**防护等级 Degree of protection: IP65**

上壳 侧出线 高结构 Hoods, side entry, high construction



螺纹 Thread	型号 Type	订货号 Part Number
M25	UTL-H24B-SEH-1L/C-M25	19300240586
M32	UTL-H24B-SEH-1L/C-M32	19300240587
M40	UTL-H24B-SEH-1L/C-M40	19300240588
PG21	UTL-H24B-SEH-1L/C-PG21	09300240580
PG29	UTL-H24B-SEH-1L/C-PG29	09300240581

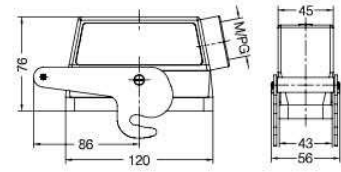

不封底下壳 Housings, bulkhead mounting



螺纹 Thread	型号 Type	订货号 Part Number
---	UTL-H24B-BK-2B/C	09300240382

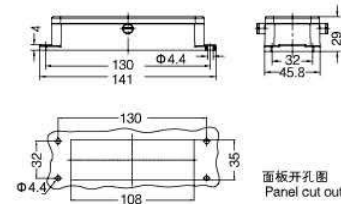

不封底下壳 Housings, bulkhead mounting



螺纹 Thread	型号 Type	订货号 Part Number
---	UTL-H24B-BK-2B/B	09300240381

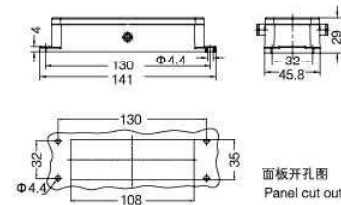

上壳侧出线/顶出线 高结构 Hoods, side&top entry, high construction



型号为:UTL-H24B-SEH/TEH-4B-XX/XX  
如有需要请与我司联系

# Metal Hoods & Housings For Higher Environmental Requirements

## 24B 金属外壳 - 适用苛刻环境 (耐腐蚀)

**防护等级 Degree of protection: IP65**

上壳 侧出线 Hoods, side entry



螺纹 Thread	型号 Type	订货号 Part Number
M25	UTL-H24B-MSE-4B-M25	19370241521
PG21	UTL-H24B-MSE-4B-PG21	09370241520

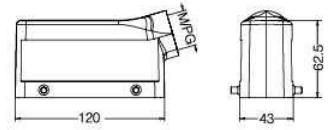

上壳 侧出线 高结构 Hoods, side entry, high construction



螺纹 Thread	型号 Type	订货号 Part Number
M32	UTL-H24B-MSEH-4B-M32	19370240527
M40	UTL-H24B-MSEH-4B-M40	19370240528
PG29	UTL-H24B-MSEH-4B-PG29	09370240521

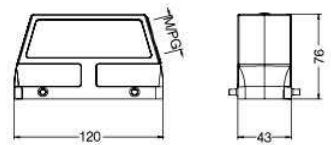

上壳 顶出线 Hoods, top entry



螺纹 Thread	型号 Type	订货号 Part Number
M25	UTL-H24B-MTE-4B-M25	19370241421
PG29	UTL-H24B-MTE-4B-PG29	09370240421

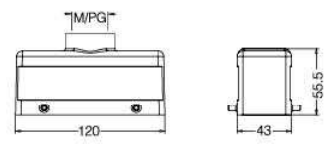

上壳 顶出线 高结构 Hoods, top entry, high construction



螺纹 Thread	型号 Type	订货号 Part Number
M32	UTL-H24B-MTEH-4B-M32	19370240427
M40	UTL-H24B-MTEH-4B-M40	19370240428
PG29	UTL-H24B-MTEH-4B-PG29	09370240427

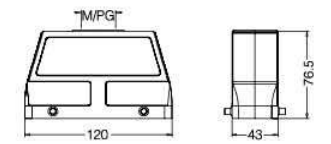

不封底下壳 Housings, bulkhead mounting



螺纹 Thread	型号 Type	订货号 Part Number
---	UTL-H24B-MBK-2L	09370240301

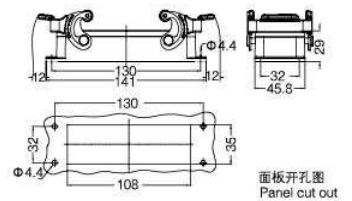

封底下壳 Housings, surface mounting



螺纹 Thread	型号 Type	订货号 Part Number
M25	UTL-H24B-MSF-2L-M25	19370240221
2M25	UTL-H24B-MSF-2L-2M25	19370240271
2M32	UTL-H24B-MSF-2L-2M32	19370240272
PG21	UTL-H24B-MSF-2L-PG21	09370240220
2PG21	UTL-H24B-MSF-2L-2PG21	09370240270
2PG29	UTL-H24B-MSF-2L-2PG29	09370240271

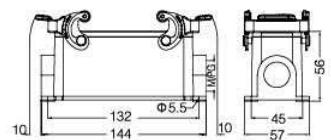

# Metal Hoods & Housings For Higher Environmental Requirements

## 24B 金属外壳 - 适用苛刻环境 (耐腐蚀)

### 防护等级 Degree of protection: IP65

封底下壳 高结构 Housings, surface mounting, high construction



螺纹 Thread	型号 Type	订货号 Part Number
2M32	UTL-H24B-MSFH-2L-2M32	19370240272
2PG29	UTL-H24B-MSFH-2L-2PG29	09370240272

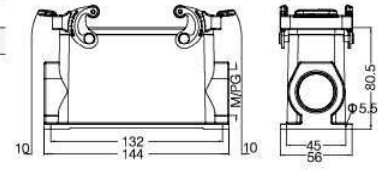

防护盖 Protection covers, metal



接线方式 Connect way	描述 Applications	型号 Type	订货号 Part Number
	防护金属盖/用于上壳 For hoods	UTL-H24B-MMCV-4B/1	09370245404
	防护金属盖/用于下壳 For housings	UTL-H24B-MMCV-4B/2	09370245405

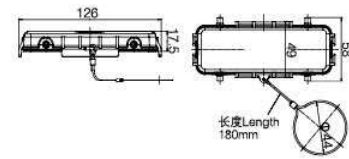

防护盖 Protection covers, metal



接线方式 Connect way	描述 Applications	型号 Type	订货号 Part Number
	防护金属盖/用于上壳 For hoods	UTL-H24B-MMCV-2L 1S	09370245402
	防护金属盖/用于下壳 For housings	UTL-H24B-MMCV-2L 2S	09370245403

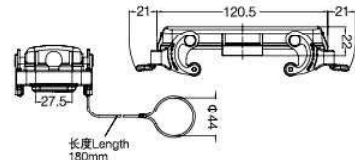

上壳 侧出线 高结构 Hoods, side entry, high construction



螺纹 Thread	型号 Type	订货号 Part Number
M32	UTL-H24B-MSEH-1L/C-M32	19370240587
PG29	UTL-H24B-MSEH-1L/C-PG29	09370240587

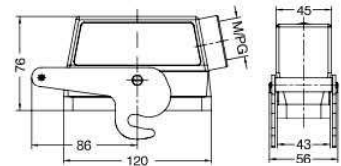

不封底下壳 Housings, bulkhead mounting



螺纹 Thread	型号 Type	订货号 Part Number
---	UTL-H24B-MBK-2B/C	09370240381

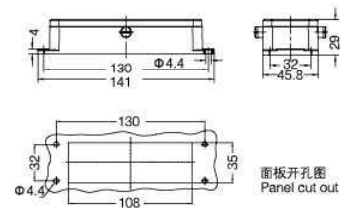



# Metal Hoods & Housings For Higher Environmental Requirements

## 24B 金属外壳 - 适用苛刻环境 (耐腐蚀)

**防护等级 Degree of protection: IP68**

上壳 侧出线 高结构 Hoods, side entry, high construction



螺纹 Thread	型号 Type	订货号 Part Number
M25	UTL-HP24B-SEH-2S-M25	19400240211
M32	UTL-HP24B-SEH-2S-M32	19400240212
M40	UTL-HP24B-SEH-2S-M40	19400240213
PG21	UTL-HP24B-SEH-2S-PG21	09400240212
PG29	UTL-HP24B-SEH-2S-PG29	09400240213

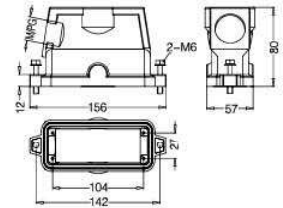

上壳 顶出线 高结构 Hoods, top entry, high construction



螺纹 Thread	型号 Type	订货号 Part Number
M25	UTL-HP24B-TEH-2S-M25	19400240221
M32	UTL-HP24B-TEH-2S-M32	19400240222
M40	UTL-HP24B-TEH-2S-M40	19400240223
M50	UTL-HP24B-TEH-2S-M50	19400240224
PG21	UTL-HP24B-TEH-2S-PG21	09400240222
PG29	UTL-HP24B-TEH-2S-PG29	09400240223
PG36	UTL-HP24B-TEH-2S-PG36	09400240224

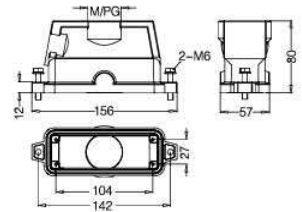

封底下壳 高结构 Housings, surface mounting, high construction



螺纹 Thread	型号 Type	订货号 Part Number
M25	UTL-HP24B-SFH-2H-M25	19400240231
M32	UTL-HP24B-SFH-2H-M32	19402240232
M40	UTL-HP24B-SFH-2H-M40	19400240233
PG21	UTL-HP24B-SFH-2H-PG21	09400240232
PG29	UTL-HP24B-SFH-2H-PG29	09400240233

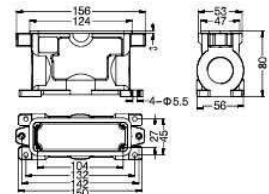

不封底下壳 Housings, bulkhead mounting



螺纹 Thread	型号 Type	订货号 Part Number
---	UTL-HP24B-BK-2H	09400240201

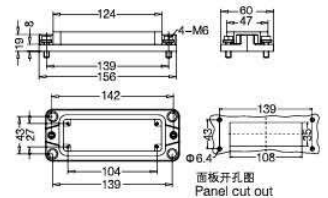

面板开孔图  
Panel cut out

不封底下壳 Housings, bulkhead mounting



螺纹 Thread	型号 Type	订货号 Part Number
---	UTL-HP24B-BK/S-2H	09400240202

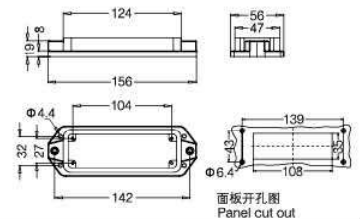

面板开孔图  
Panel cut out

塑料防护盖 Protection covers, plastic



螺纹 Thread	型号 Type	订货号 Part Number
---	UTL-HP24B-CV-2S/2	09400240205

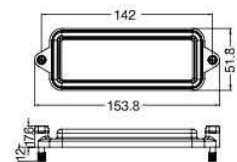

# Hoods & Housings For Harsh Environmental Requirements

## 24B 高防护外壳

防护等级 Degree of protection: IP68

上壳 侧出线 高结构 Hoods, side entry, high construction



螺纹 Thread	型号 Type	订货号 Part Number
螺栓联锁 Screw locking		
M25	UTL-HP24B/H-SEH-2S-M25	19400240511
M32	UTL-HP24B/H-SEH-2S-M32	19400240512
M40	UTL-HP24B/H-SEH-2S-M40	19400240513
M50	UTL-HP24B/H-SEH-2S-M50	19400240514
2M32	UTL-HP24B/H-SEH-2S-2M32	19400240537
PG21	UTL-HP24B/H-SEH-2S-PG21	09400240512
PG29	UTL-HP24B/H-SEH-2S-PG29	09400240513
PG36	UTL-HP24B/H-SEH-2S-PG36	09400240514
轴销联锁 Toggle locking		
M25	UTL-HP24B/H-SEH-2T-M25	19400240501
M32	UTL-HP24B/H-SEH-2T-M32	19400240502
M40	UTL-HP24B/H-SEH-2T-M40	19400240503
PG21	UTL-HP24B/H-SEH-2T-PG21	09400240502
PG25	UTL-HP24B/H-SEH-2T-PG29	09400240503
PG36	UTL-HP24B/H-SEH-2T-PG36	09400240504

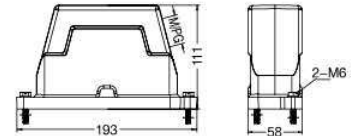

上壳 顶出线 高结构 Hoods, top entry, high construction



螺纹 Thread	型号 Type	订货号 Part Number
螺栓联锁 Screw locking		
M25	UTL-HP24B/H-TEH-2S-M25	19400240411
M32	UTL-HP24B/H-TEH-2S-M32	19400240412
M40	UTL-HP24B/H-TEH-2S-M40	19400240413
M50	UTL-HP24B/H-TEH-2S-M50	19400240414
PG21	UTL-HP24B/H-TEH-2S-PG21	09400240412
PG29	UTL-HP24B/H-TEH-2S-PG29	09400240413
PG36	UTL-HP24B/H-TEH-2S-PG36	09400240414
轴销联锁 Toggle locking		
M25	UTL-HP24B/H-TEH-2T-M25	19400240401
M32	UTL-HP24B/H-TEH-2T-M32	19400240402
M40	UTL-HP24B/H-TEH-2T-M40	19400240403
M50	UTL-HP24B/H-TEH-2T-M50	19400240404
PG21	UTL-HP24B/H-TEH-2T-PG21	09400240402
PG29	UTL-HP24B/H-TEH-2T-PG29	09400240403
PG36	UTL-HP24B/H-TEH-2T-PG36	09400240404

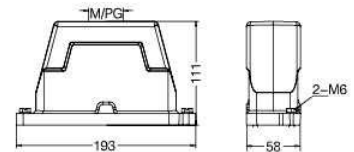

上壳 顶出线 高结构 Hoods, top entry, high construction



螺纹 Thread	型号 Type	订货号 Part Number
螺栓联锁 Screw locking		
M63	UTL-HP24B/H-TEH-2S-M63	19400240420
轴销联锁 Toggle locking		
M63	UTL-HP24B/H-TEH-2T-M63	19400240410

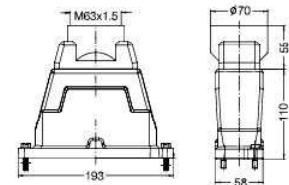

不封底下壳 Housings, bulkhead mounting



螺纹 Thread	型号 Type	订货号 Part Number
螺栓联锁 Screw locking		
---	UTL-HP24B/H-BK-2H	09400240311
轴销联锁 Toggle locking		
---	UTL-HP24B/H-BK-2T	09400240301
带金属盖 With Metal Cover		
螺栓联锁 Screw locking		
---	UTL-HP24B/H-BK-2H-MCV	09400240317
轴销联锁 Toggle locking		
---	UTL-HP24B/H-BK-2T-MCV	09400240307

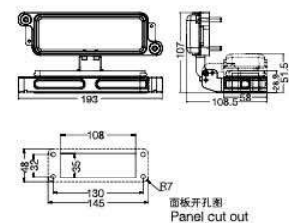



# Hoods & Housings For Harsh Environmental Requirements

## 24B 高防护外壳

**防护等级 Degree of protection: IP68**

上壳 侧出线 高结构 Hoods, side entry, high construction



螺纹 Thread	型号 Type	订货号 Part Number
M25	UTL-HP24B/H-SEH-4S-M25	19400241361
M32	UTL-HP24B/H-SEH-4S-M32	19400241362
M40	UTL-HP24B/H-SEH-4S-M40	19400241363
PG21	UTL-HP24B/H-SEH-4S-PG21	09400241362
PG29	UTL-HP24B/H-SEH-4S-PG29	09400241363

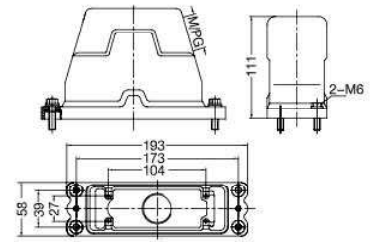

上壳 顶出线 高结构 Hoods, top entry, high construction



螺纹 Thread	型号 Type	订货号 Part Number
M25	UTL-HP24B/H-TEH-4S-M25	19400241461
M32	UTL-HP24B/H-TEH-4S-M32	19400241462
M40	UTL-HP24B/H-TEH-4S-M40	19400241463
M50	UTL-HP24B/H-TEH-4S-M50	19400241464
PG21	UTL-HP24B/H-TEH-4S-PG21	09400241461
PG29	UTL-HP24B/H-TEH-4S-PG29	09400241462
PG36	UTL-HP24B/H-TEH-4S-PG36	09400241463

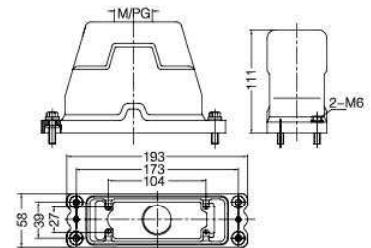

上壳 顶出线 高结构 Hoods, top entry, high construction



螺纹 Thread	型号 Type	订货号 Part Number
3M32	UTL-HP24B/H-TEHH-4S-3M32	19400241566

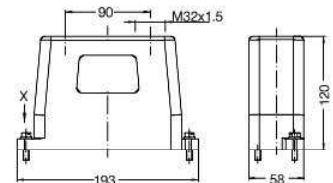

上壳 顶出线 高结构 Hoods, top entry, high construction



螺纹 Thread	型号 Type	订货号 Part Number
M63	UTL-HP24B/H-TEH-4S-M63	19400241520

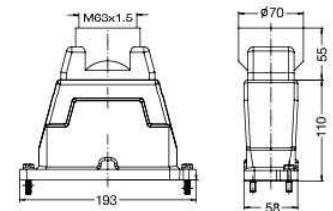

不封底下壳 Housings, bulkhead mounting



螺纹 Thread	型号 Type	订货号 Part Number
---	UTL-HP24B/H-BK-4H	09400240202

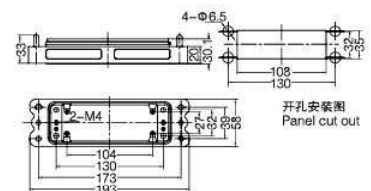

# Hoods & Housings For Harsh Environmental Requirements

## 24B 高防护外壳

**防护等级 Degree of protection: IP68**

整体型外壳 侧出线 高结构 Hoods, side entry, high construction



螺纹 Thread	型号 Type	订货号 Part Number
M32	UTL-HC24B-SEH-2S-M32	19400241501
M40	UTL-HC24B-SEH-2S-M40	19400241502
PG21	UTL-HC24B-SEH-2S-PG21	09400241501
PG29	UTL-HC24B-SEH-2S-PG29	09400241502

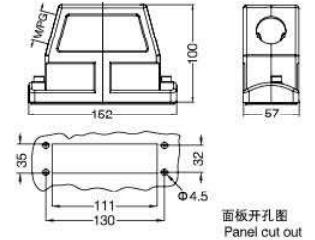

整体型外壳 顶出线 高结构 Hoods, top entry, high construction



螺纹 Thread	型号 Type	订货号 Part Number
M32	UTL-HC24B-TEH-2S-M32	19400241551
M40	UTL-HC24B-TEH-2S-M40	19400241552
PG21	UTL-HC24B-TEH-2S-PG21	09400241551
PG29	UTL-HC24B-TEH-2S-PG29	09400241552

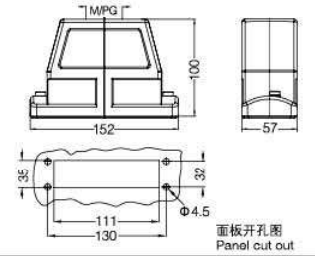

芯体安装支块 Mounting frames



描述 Applications	型号 Type	订货号 Part Number
整体型外壳适配 For integral type hoods	UTL-APT-C	09400241600

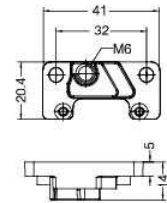

# Metal Hoods & Housings For High Voltage Inserts(HVE Series)

## UTL-HV24B 金属外壳 适用高压插芯 (HVE 系列)

**防护等级 Degree of protection: IP65**

上壳 侧出线 Hoods, side entry



螺纹 Thread	型号 Type	订货号 Part Number
M25	UTL-HV24B-SE-2B-M25	19340241541
M32	UTL-HV24B-SE-2B-M32	19340241542
PG21	UTL-HV24B-SE-2B-PG21	09340241540

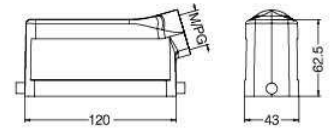

上壳 侧出线 高结构 Hoods, side entry, high construction



螺纹 Thread	型号 Type	订货号 Part Number
M32	UTL-HV24B-SEH-2B-M32	19340240547
M40	UTL-HV24B-SEH-2B-M40	19340240548
PG21	UTL-HV24B-SEH-2B-PG21	09340240540
PG29	UTL-HV24B-SEH-2B-PG29	09340240541
PG36	UTL-HV24B-SEH-2B-PG36	09340240546

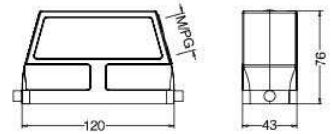

上壳 顶出线 Hoods, top entry



螺纹 Thread	型号 Type	订货号 Part Number
M25	UTL-HV24B-TE-2B-M25	19340241441
M32	UTL-HV24B-TE-2B-M32	19340241442
PG21	UTL-HV24B-TE-2B-PG21	09340241440
PG29	UTL-HV24B-TE-2B-PG29	09340241441

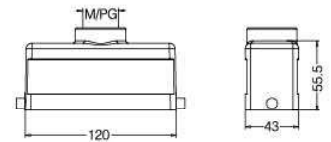

上壳 顶出线 高结构 Hoods, top entry, high construction



螺纹 Thread	型号 Type	订货号 Part Number
M32	UTL-HV24B-TEH-2B-M32	19340240447
M40	UTL-HV24B-TEH-2B-M40	19340240448
PG21	UTL-HV24B-TEH-2B-PG21	09340240440
PG29	UTL-HV24B-TEH-2B-PG29	09340240441
PG36	UTL-HV24B-TEH-2B-PG36	09340240446

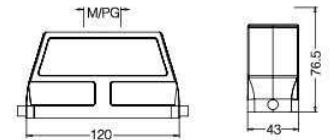

飞线下壳 Housings, cable to cable



螺纹 Thread	型号 Type	订货号 Part Number
M25	UTL-HV24B-CCT-1L-M25	19340241751
M32	UTL-HV24B-CCT-1L-M32	19340241752
PG21	UTL-HV24B-CCT-1L-PG21	09340241750
PG29	UTL-HV24B-CCT-1L-PG29	09340241751

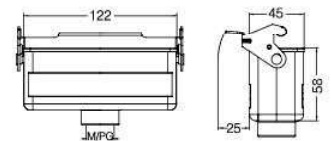

飞线下壳 高结构 Housings, cable to cable, high construction



螺纹 Thread	型号 Type	订货号 Part Number
M32	UTL-HV24B-CCTH-1L-M32	19340240757
M40	UTL-HV24B-CCTH-1L-M40	19340240758
PG21	UTL-HV24B-CCTH-1L-PG21	09340240750
PG29	UTL-HV24B-CCTH-1L-PG29	09340240751

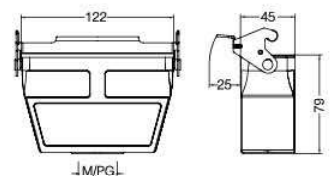

# Metal Hoods & Housings For High Voltage Inserts(HVE Series)

## UTL-HV24B 金属外壳 适用高压插芯 (HVE 系列)

**防护等级 Degree of protection: IP65**

不封底下壳 Housings, bulkhead mounting



螺纹 Thread	型号 Type	订货号 Part Number
---	UTL-HV24B-BK-1L	09340240307
	带塑料盖 With Plastic Cover	
---	UTL-HV24B-BK-1L-CV	09340240304
	带金属盖 With Metal Cover	
---	UTL-HV24B-BK-1L-MCV	09340240318

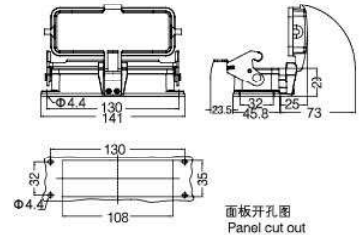

封底下壳 Housings, surface mounting



螺纹 Thread	型号 Type	订货号 Part Number
M25	UTL-HV24B-SF-1L-M25	19340241251
2M25	UTL-HV24B-SF-1L-2M25	19340241291
PG21	UTL-HV24B-SF-1L-PG21	09340241250
2PG21	UTL-HV24B-SF-1L-2PG21	09340241290
	带塑料盖 With Plastic Cover	
M25	UTL-HV24B-SF-1L-CV-M25	19340241256
2M25	UTL-HV24B-SF-1L-CV-2M25	19340241296
PG21	UTL-HV24B-SF-1L-CV-PG21	09340241255
2PG21	UTL-HV24B-SF-1L-CV-2PG21	09340241295
	带金属盖 With Metal Cover	
M25	UTL-HV24B-SF-1L-MCV-M25	19340242256
2M25	UTL-HV24B-SF-1L-MCV-2M25	19340242296
PG21	UTL-HV24B-SF-1L-MCV-PG21	09340242255
2PG21	UTL-HV24B-SF-1L-MCV-2PG21	09340242295

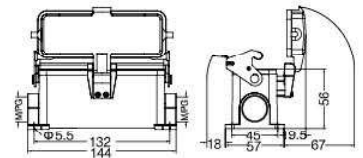

封底下壳 高结构 Housings, surface mounting, high construction



螺纹 Thread	型号 Type	订货号 Part Number
M32	UTL-HV24B-SFH-1L-M32	19340240252
2M32	UTL-HV24B-SFH-1L-2M32	19340240292
PG21	UTL-HV24B-SFH-1L-PG21	09340240250
2PG21	UTL-HV24B-SFH-1L-2PG21	09340240290
PG29	UTL-HV24B-SFH-1L-PG29	09340240251
2PG29	UTL-HV24B-SFH-1L-2PG29	09340240291
	带塑料盖 With Plastic Cover	
M32	UTL-HV24B-SFH-1L-CV-M32	19340240257
2M32	UTL-HV24B-SFH-1L-CV-2M32	19340240297
PG21	UTL-HV24B-SFH-1L-CV-PG21	09340240255
2PG21	UTL-HV24B-SFH-1L-CV-2PG21	09340240295
PG29	UTL-HV24B-SFH-1L-CV-PG29	09340240256
2PG29	UTL-HV24B-SFH-1L-CV-2PG29	09340240296
	带金属盖 With Metal Cover	
M32	UTL-HV24B-SFH-1L-MCV-M32	19340247257
2M32	UTL-HV24B-SFH-1L-MCV-2M32	19340247297
PG21	UTL-HV24B-SFH-1L-MCV-PG21	09340242257
2PG21	UTL-HV24B-SFH-1L-MCV-2PG21	09340242297
PG29	UTL-HV24B-SFH-1L-MCV-PG29	09340242258
2PG29	UTL-HV24B-SFH-1L-MCV-2PG29	09340242298

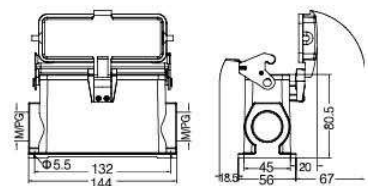

# Metal Hoods & Housings For High Voltage Inserts(HVE Series)

## UTL-HV24B 金属外壳 适用高压播芯 (HVE 系列)

**防护等级 Degree of protection: IP65**

封底下壳 高结构 Housings, surface mounting, high construction



螺纹 Thread	型号 Type	订货号 Part Number
M32	UTL-HV24B-SFH-2L-M32	19340240232
2M32	UTL-HV24B-SFH-2L-2M32	19340240272
2M40	UTL-HV24B-SFH-2L-2M40	19340240273
PG21	UTL-HV24B-SFH-2L-PG21	09340240230
2PG21	UTL-HV24B-SFH-2L-2PG21	09340240270
PG29	UTL-HV24B-SFH-2L-PG29	09340240231
2PG29	UTL-HV24B-SFH-2L-2PG29	09340240271

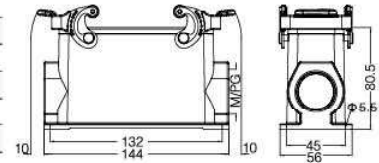

飞线下壳 Housings, cable to cable



螺纹 Thread	型号 Type	订货号 Part Number
M25	UTL-HV24B-CCT-2L-M25	19340241731
M32	UTL-HV24B-CCT-2L-M32	19340240732
PG21	UTL-HV24B-CCT-2L-PG21	09340241730
PG29	UTL-HV24B-CCT-2L-PG29	09340241731

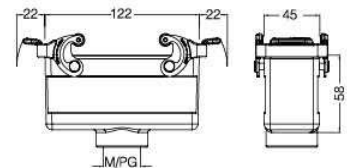

飞线下壳 高结构 Housings, cable to cable, high construction



螺纹 Thread	型号 Type	订货号 Part Number
M32	UTL-HV24B-CCTH-2L-M32	19340240737
M40	UTL-HV24B-CCTH-2L-M40	19340240738
PG21	UTL-HV24B-CCTH-2L-PG21	09340240730
PG29	UTL-HV24B-CCTH-2L-PG29	09340240731

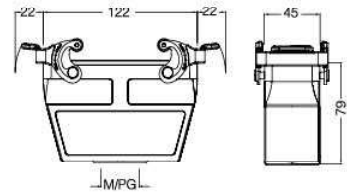

塑料防护盖 4卡扣 Protection covers, plastic



接线方式 Connect way	描述 Applications	型号 Type	订货号 Part Number
---	用于上壳 For hoods	UTL-H24B-CV-4C	09340245401

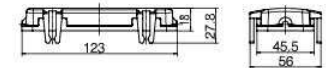

塑料防护盖 Protection covers, plastic



接线方式 Connect way	描述 Applications	型号 Type	订货号 Part Number
○	塑料盖/用于飞线下壳 For Housings,cable to cable	UTL-H24B-CV-4B/1	09300245425
●	塑料盖/用于不封底,封底下壳 For housing,bulkhead/UTL-H24B-CV-4B/2 surface mounting	UTL-H24B-CV-4B/2	09300245426

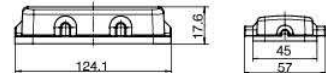



# Metal Hoods & Housings For High Voltage Inserts(HVE Series)

## UTL-HV24B 金属外壳 适用高压插芯 (HVE 系列)

**防护等级 Degree of protection: IP65**

上壳 侧出线 Hoods, side entry



螺纹 Thread	型号 Type	订货号 Part Number
M25	UTL-HV24B-SE-4B-M25	19340240521
M32	UTL-HV24B-SE-4B-M32	19340241522
PG21	UTL-HV24B-SE-4B-PG21	09340241520

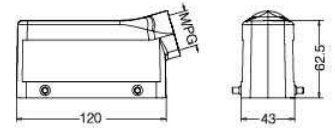

上壳 侧出线 高结构 Hoods, side entry, high construction



螺纹 Thread	型号 Type	订货号 Part Number
M32	UTL-HV24B-SEH-4B-M32	19340240527
M40	UTL-HV24B-SEH-4B-M40	19340240528
PG21	UTL-HV24B-SEH-4B-PG21	09340240520
PG29	UTL-HV24B-SEH-4B-PG29	09340240521

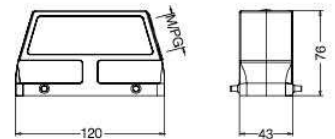

上壳 顶出线 Hoods, top entry



螺纹 Thread	型号 Type	订货号 Part Number
M25	UTL-HV24B-TE-4B-M25	19340240422
M32	UTL-HV24B-TE-4B-M32	19340241422
PG21	UTL-HV24B-TE-4B-PG21	09340241420
PG29	UTL-HV24B-TE-4B-PG29	09340241421

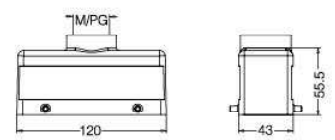

上壳 顶出线 高结构 Hoods, top entry, high construction



螺纹 Thread	型号 Type	订货号 Part Number
M32	UTL-HV24B-TEH-4B-M32	19340240427
M40	UTL-HV24B-TEH-4B-M40	19340240428
PG21	UTL-HV24B-TEH-4B-PG21	09340240420
PG29	UTL-HV24B-TEH-4B-PG29	09340240421

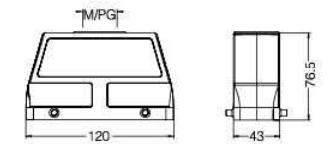

不封底下壳 Housings, bulkhead mounting



螺纹 Thread	型号 Type	订货号 Part Number
---	UTL-HV24B-BK-2L	09340240301

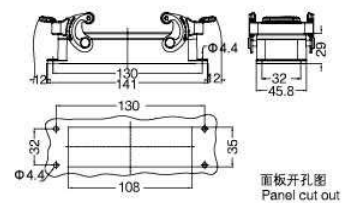

封底下壳 Housings, surface mounting



螺纹 Thread	型号 Type	订货号 Part Number
M25	UTL-HV24B-SF-2L-M25	19340240271
2M25	UTL-HV24B-SF-2L-2M25	19340241271
PG21	UTL-HV24B-SF-2L-PG21	09340241230
2PG21	UTL-HV24B-SF-2L-2PG21	09340241270

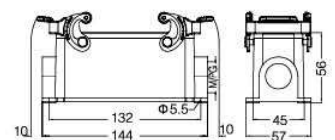

# Metal Hoods & Housings For High Voltage Inserts(HVE Series)

## UTL-HV24B 金属外壳 适用高压播芯 (HVE 系列)

**防护等级 Degree of protection: IP65**

上壳 侧出线 Hoods, side entry



螺纹 Thread	型号 Type	订货号 Part Number
M25	UTL-HV24B-SE-2L-M25	19340241531
M32	UTL-HV24B-SE-2L-M32	19340241532
PG21	UTL-HV24B-SE-2L-PG21	09340241530

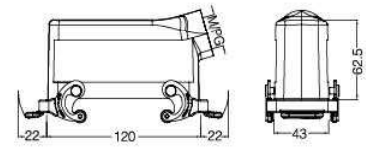

上壳 侧出线 高结构 Hoods, side entry, high construction



螺纹 Thread	型号 Type	订货号 Part Number
M32	UTL-HV24B-SEH-2L-M32	19340240537
M40	UTL-HV24B-SEH-2L-M40	19340240538
PG21	UTL-HV24B-SEH-2L-PG21	09340240530
PG29	UTL-HV24B-SEH-2L-PG29	09340240531

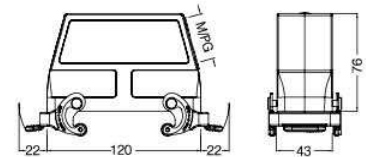

上壳 顶出线 Hoods, top entry



螺纹 Thread	型号 Type	订货号 Part Number
M25	UTL-HV24B-TE-2L-M25	19340241431
M32	UTL-HV24B-TE-2L-M32	19340241432
PG21	UTL-HV24B-TE-2L-PG21	09340241430
PG29	UTL-HV24B-TE-2L-PG29	09340241431

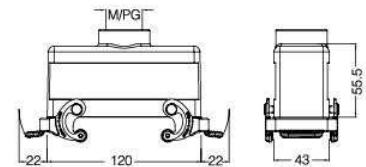

上壳 顶出线 高结构 Hoods, top entry, high construction



螺纹 Thread	型号 Type	订货号 Part Number
M32	UTL-HV24B-TEH-2L-M32	19340240437
M40	UTL-HV24B-TEH-2L-M40	19340240438
PG21	UTL-HV24B-TEH-2L-PG21	09340240430
PG29	UTL-HV24B-TEH-2L-PG29	09340240431

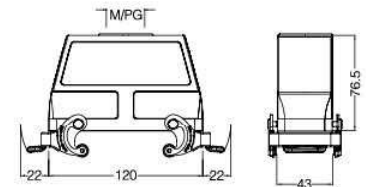

不封底下壳 Housings, bulkhead mounting



螺纹 Thread	型号 Type	订货号 Part Number
---	UTL-HV24B-BK-4B	09340240300
	带塑料盖 With Plastic Cover	
---	UTL-HV24B-BK-4B-CV	09340240302
	带金属盖 With Metal Cover	
---	UTL-HV24B-BK-4B-MCV	09340240317

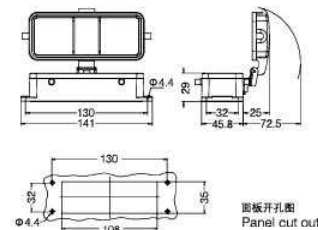

# Metal Hoods & Housings For High Voltage Inserts(HVE Series)

## UTL-HV24B 金属外壳 适用高压插芯 (HVE 系列)

**防护等级 Degree of protection: IP65**

封底下壳 Housings, surface mounting



螺纹 Thread	型号 Type	订货号 Part Number
M25	UTL-HV24B-SF-4B-M25	19340241126
2M25	UTL-HV24B-SF-4B-2M25	19340241166
PG21	UTL-HV24B-SF-4B-PG21	09340241120
2PG21	UTL-HV24B-SF-4B-2PG21	09340241160
带塑料盖 With Plastic Cover		
M25	UTL-HV24B-SF-4B-CV-M25	19340241226
2M25	UTL-HV24B-SF-4B-CV-2M25	19340241266
PG21	UTL-HV24B-SF-4B-CV-PG21	09340241220
2PG21	UTL-HV24B-SF-4B-CV-2PG21	09340241260
带金属盖 With Metal Cover		
M25	UTL-HV24B-SF-4B-MCV-M25	19340242226
2M25	UTL-HV24B-SF-4B-MCV-2M25	19340242266
PG21	UTL-HV24B-SF-4B-MCV-PG21	09340242220
2PG21	UTL-HV24B-SF-4B-MCV-2PG21	09340242260

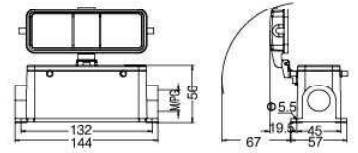

封底下壳 高结构 Housings, surface mounting, high construction



螺纹 Thread	型号 Type	订货号 Part Number
M32	UTL-HV24B-SFH-4B-M32	19340240127
2M32	UTL-HV24B-SFH-4B-2M32	19340240167
PG21	UTL-HV24B-SFH-4B-PG21	09340240120
2PG21	UTL-HV24B-SFH-4B-2PG21	09340240160
PG29	UTL-HV24B-SFH-4B-PG29	09340240121
2PG29	UTL-HV24B-SFH-4B-2PG29	09340240161
带塑料盖 With Plastic Cover		
M32	UTL-HV24B-SFH-4B-CV-M32	19340240227
2M32	UTL-HV24B-SFH-4B-CV-2M32	19340240267
PG21	UTL-HV24B-SFH-4B-CV-PG21	09340240220
2PG21	UTL-HV24B-SFH-4B-CV-2PG21	09340240260
PG29	UTL-HV24B-SFH-4B-CV-PG29	09340240221
2PG29	UTL-HV24B-SFH-4B-CV-2PG29	09340240261
带金属盖 With Metal Cover		
M32	UTL-HV24B-SFH-4B-MCV-M32	19340242222
2M32	UTL-HV24B-SFH-4B-MCV-2M32	19340242262
PG21	UTL-HV24B-SFH-4B-MCV-PG21	09340242222
2PG21	UTL-HV24B-SFH-4B-MCV-2PG21	09340242262
PG29	UTL-HV24B-SFH-4B-MCV-PG29	09340242223
2PG29	UTL-HV24B-SFH-4B-MCV-2PG29	09340242263

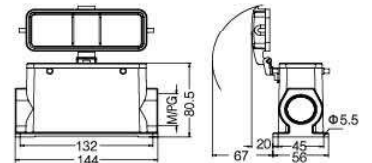

防护盖 Protection covers, metal



接线方式 Connect way	描述 Applications	型号 Type	订货号 Part Number
	金属保护盖/用于上壳 For hoods	UTL-H24B-MCV-4B/1	09300245442
	金属保护盖/用于下壳 For housings	UTL-H24B-MCV-4B/2	09340245443

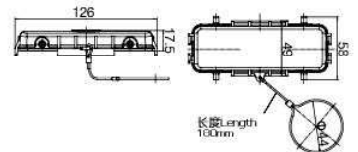

防护盖 Protection covers, metal



接线方式 Connect way	描述 Applications	型号 Type	订货号 Part Number
	金属保护盖/用于上壳 For hoods	UTL-H24B-MCV-2L.1S	09300245422
	金属保护盖/用于下壳 For housings	UTL-H24B-MCV-2L.2S	09340245423

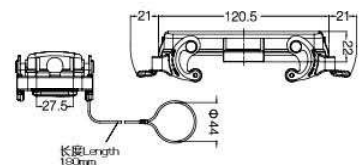

# Metal Hoods & Housings For High Voltage Inserts(HVE Series)

## UTL-HV24B 金属外壳 适用高压播芯 (HVE 系列)

**防护等级 Degree of protection: IP65**

上壳 侧出线 高结构 Hoods, side entry, high construction



螺纹 Thread	型号 Type	订货号 Part Number
M25	UTL-HV24B-SEH-1L/C-M25	19340240586
M32	UTL-HV24B-SEH-1L/C-M32	19340240587
M40	UTL-HV24B-SEH-1L/C-M40	19340240588
PG21	UTL-HV24B-SEH-1L/C-PG21	09340240580
PG29	UTL-HV24B-SEH-1L/C-PG29	09340240581

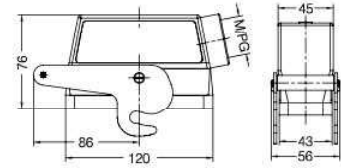

不封底下壳 Housings, bulkhead mounting



螺纹 Thread	型号 Type	订货号 Part Number
---	UTL-HV24B-BK-2B/C	09340240382

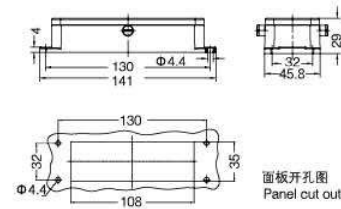

不封底下壳 Housings, bulkhead mounting



螺纹 Thread	型号 Type	订货号 Part Number
---	UTL-HV24B-BK-2B/B	09340240381

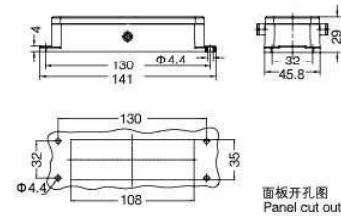

# Metal Hoods & Housings

## 32B 金属外壳

防护等级 Degree of protection: IP65

上壳 侧出线 Hoods, side entry



螺纹 Thread	型号 Type	订货号 Part Number
M32	UTL-H32B-SE-2B-M32	19300320547
M40	UTL-H32B-SE-2B-M40	19300320548
M50	UTL-H32B-SE-2B-M50	19300320549
PG29	UTL-H32B-SE-2B-PG29	09300320541
PG36	UTL-H32B-SE-2B-PG36	09300320542
PG42	UTL-H32B-SE-2B-PG42	09300320543

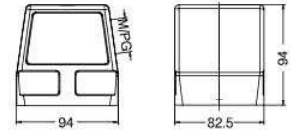

上壳 顶出线 Hoods, top entry



螺纹 Thread	型号 Type	订货号 Part Number
M32	UTL-H32B-TE-2B-M32	19300320447
M40	UTL-H32B-TE-2B-M40	19300320448
M50	UTL-H32B-TE-2B-M50	19300320449
PG29	UTL-H32B-TE-2B-PG29	09300320441
PG36	UTL-H32B-TE-2B-PG36	09300320442
PG42	UTL-H32B-TE-2B-PG42	09300320443

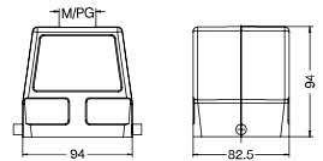

不封底下壳 Housings, bulkhead mounting



螺纹 Thread	型号 Type	订货号 Part Number
---	UTL-H32B-BK-1L	09300320307
---	带塑料盖 With plastic cover	
---	UTL-H32B-BK-1L-CV	09300320304
---	带金属盖 With metal cover	
---	UTL-H32B-BK-1L-MCV	09300320318

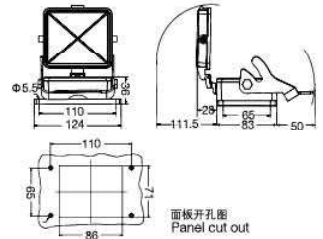

封底下壳 Housings, surface mounting



螺纹 Thread	型号 Type	订货号 Part Number
M32	UTL-H32B-SF-1L-M32	19300320252
2M32	UTL-H32B-SF-1L-2M32	19300320292
M40	UTL-H32B-SF-1L-M40	19300320253
2M40	UTL-H32B-SF-1L-2M40	19300320293
M50	UTL-H32B-SF-1L-M50	19300320254
PG29	UTL-H32B-SF-1L-PG29	09300320251
2PG29	UTL-H32B-SF-1L-2PG29	09300320291
PG36	UTL-H32B-SF-1L-PG36	09300320252
2PG36	UTL-H32B-SF-1L-2PG36	09300320292
---	带塑料盖 With plastic cover	
M32	UTL-H32B-SF-1L-CV-M32	19300320257
2M32	UTL-H32B-SF-1L-CV-2M32	19300320297
M40	UTL-H32B-SF-1L-CV-M40	19300320258
2M40	UTL-H32B-SF-1L-CV-2M40	19300320298
PG29	UTL-H32B-SF-1L-CV-PG29	09300320257
2PG29	UTL-H32B-SF-1L-CV-2PG29	09300320297
PG36	UTL-H32B-SF-1L-CV-PG36	09300320258
2PG36	UTL-H32B-SF-1L-CV-2PG36	09300320298
---	带金属盖 With metal cover	
M32	UTL-H32B-SF-1L-MCV-M32	19300321257
2M32	UTL-H32B-SF-1L-MCV-2M32	19300321297
M40	UTL-H32B-SF-1L-MCV-M40	19300321258
2M40	UTL-H32B-SF-1L-MCV-2M40	19300321298
PG29	UTL-H32B-SF-1L-MCV-PG29	09300321257
2PG29	UTL-H32B-SF-1L-MCV-2PG29	09300321297
PG36	UTL-H32B-SF-1L-MCV-PG36	09300321258
2PG36	UTL-H32B-SF-1L-MCV-2PG36	09300321298

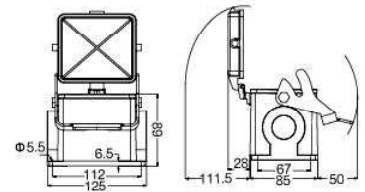

# Metal Hoods & Housings

## 32B 金属外壳

防护等级 Degree of protection: IP65

上壳 侧出线 Hoods, side entry



螺纹 Thread	型号 Type	订货号 Part Number
M32	UTL-H32B-SE-4B-M32	19300320527
M40	UTL-H32B-SE-4B-M40	19300320528
M50	UTL-H32B-SE-4B-M50	19300320529
PG29	UTL-H32B-SE-4B-PG29	09300320521
PG36	UTL-H32B-SE-4B-PG36	09300320522
PG42	UTL-H32B-SE-4B-PG42	09300320523
G2	UTL-H32B-SE-4B-G2	19300320525

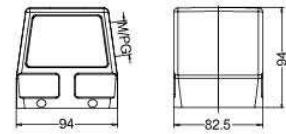

上壳 顶出线 Hoods, top entry



螺纹 Thread	型号 Type	订货号 Part Number
M32	UTL-H32B-TE-4B-M32	19300320427
M40	UTL-H32B-TE-4B-M40	19300320428
M50	UTL-H32B-TE-4B-M50	19300320429
PG29	UTL-H32B-TE-4B-PG29	09300320421
PG36	UTL-H32B-TE-4B-PG36	09300320422
PG42	UTL-H32B-TE-4B-PG42	09300320423

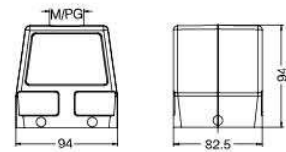

不封底下壳 Housings, bulkhead mounting



螺纹 Thread	型号 Type	订货号 Part Number
---	UTL-H32B-BK-2L	09300320301

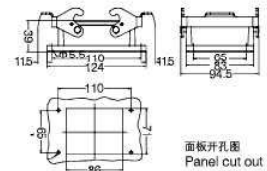

封底下壳 Housings, surface mounting



螺纹 Thread	型号 Type	订货号 Part Number
M32	UTL-H32B-SF-2L-M32	19300320232
2M32	UTL-H32B-SF-2L-2M32	19300320272
M40	UTL-H32B-SF-2L-M40	19300320233
2M40	UTL-H32B-SF-2L-2M40	19300320273
M50	UTL-H32B-SF-2L-M50	19300320234
PG29	UTL-H32B-SF-2L-PG29	09300320231
2PG29	UTL-H32B-SF-2L-2PG29	09300320271
PG36	UTL-H32B-SF-2L-PG36	09300320232
2PG36	UTL-H32B-SF-2L-2PG36	09300320272
PG42	UTL-H32B-SF-2L-PG42	09300320233
2PG42	UTL-H32B-SF-2L-2PG42	09300320273

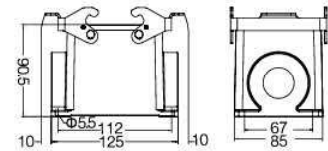

飞线下壳 Housings, cable to cable



螺纹 Thread	型号 Type	订货号 Part Number
M32	UTL-H32B-CCT-2L-M32	19300320737
M40	UTL-H32B-CCT-2L-M40	19300320738
M50	UTL-H32B-CCT-2L-M50	19300320739
PG29	UTL-H32B-CCT-2L-PG29	09300320731
PG36	UTL-H32B-CCT-2L-PG36	09300320732
PG42	UTL-H32B-CCT-2L-PG42	09300320733

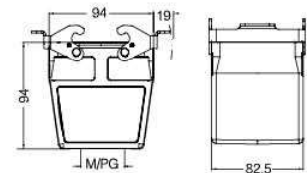

防护盖 Protection covers, metal



螺纹 Thread	型号 Type	订货号 Part Number
---	UTL-H32B-MCV-4B/2	09300325425

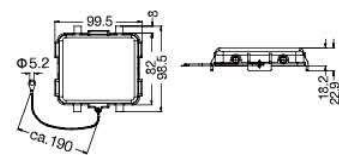

# Metal Hoods & Housings

## 32B 金属外壳

### 防护等级 Degree of protection: IP65

防护盖 Protection covers, metal



螺纹 Thread	型号 Type	订货号 Part Number
---	UTL-H32B-MCV-2L.1S	09300325420

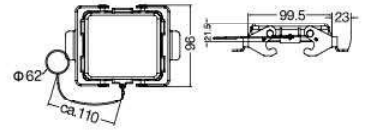

不封底下壳 Housings, bulkhead mounting



螺纹 Thread	型号 Type	订货号 Part Number
---	UTL-H32B-BK-4B	09300320301
	带塑料盖 With plastic cover	
---	UTL-H32B-BK-4B-CV	09300320302
	带金属盖 With metal cover	
---	UTL-H32B-BK-4B-MCV	09300320303

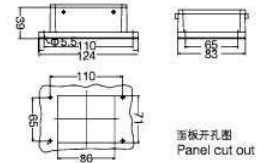

封底下壳 Housings, surface mounting



螺纹 Thread	型号 Type	订货号 Part Number
M32	UTL-H32B-SF-4B-M32	19300321126
2M32	UTL-H32B-SF-4B-2M32	19300321166
M40	UTL-H32B-SF-4B-M40	19300321127
2M40	UTL-H32B-SF-4B-2M40	19300321167
PG29	UTL-H32B-SF-4B-PG29	09300321120
2PG29	UTL-H32B-SF-4B-2PG29	09300321160
PG36	UTL-H32B-SF-4B-PG36	09300321121
2PG36	UTL-H32B-SF-4B-2PG36	09300321161
PG42	UTL-H32B-SF-4B-PG42	09300321122

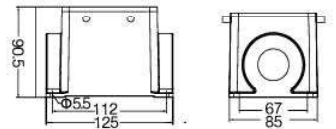

上壳 侧出线 Hoods, side entry



螺纹 Thread	型号 Type	订货号 Part Number
M32	UTL-H32B-SE-2L-M32	19300320537
PG29	UTL-H32B-SE-2L-PG29	09300320531

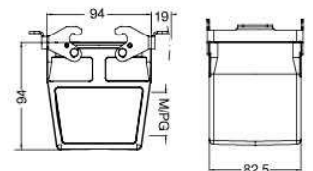

上壳 顶出线 Hoods, top entry



螺纹 Thread	型号 Type	订货号 Part Number
M32	UTL-H32B-TE-2L-M32	19300320437
M40	UTL-H32B-TE-2L-M40	19300320438
M50	UTL-H32B-TE-2L-M50	19300320439
PG29	UTL-H32B-TE-2L-PG29	09300320431
PG36	UTL-H32B-TE-2L-PG36	09300320432
PG42	UTL-H32B-TE-2L-PG42	09300320433

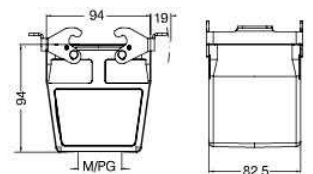

# Metal Hoods & Housings For High Voltage Inserts(HVE Series)

## UTL-HV32B 金属外壳 - 适用高压播芯 (HVE 系列)

**防护等级 Degree of protection: IP65**

上壳 侧出线 Hoods, side entry



螺纹 Thread	型号 Type	订货号 Part Number
M32	UTL-HV32B-SE-2B-M32	19340320547
PG29	UTL-HV32B-SE-2B-PG29	09400320541
PG36	UTL-HV32B-SE-2B-PG36	09340320542
PG42	UTL-HV32B-SE-2B-PG42	09340320543

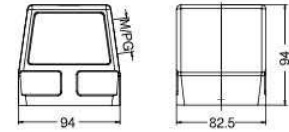

上壳 顶出线 Hoods, top entry



螺纹 Thread	型号 Type	订货号 Part Number
M32	UTL-HV32B-TE-2B-M32	19340320447
M40	UTL-HV32B-TE-2B-M40	19340320448
M50	UTL-HV32B-TE-2B-M50	19340320449
PG29	UTL-HV32B-TE-2B-PG29	09340320441
PG36	UTL-HV32B-TE-2B-PG36	09340320442
PG42	UTL-HV32B-TE-2B-PG42	09340320443

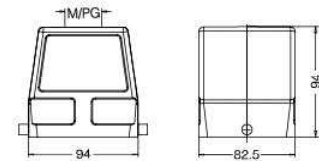

不封底下壳 Housings, bulkhead mounting



螺纹 Thread	型号 Type	订货号 Part Number
---	UTL-HV32B-BK-1L	09340320307
	带塑料盖 With plastic cover	
---	UTL-HV32B-BK-1L-CV	09340320304
	带金属盖 With metal cover	
---	UTL-HV32B-BK-1L-MCV	09340320318

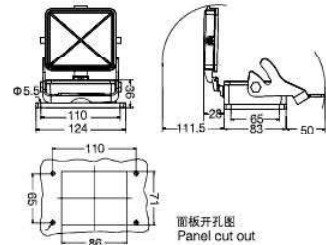

封底下壳 Housings, surface mounting



螺纹 Thread	型号 Type	订货号 Part Number
M32	UTL-HV32B-SF-1L-M32	19340320252
2M32	UTL-HV32B-SF-1L-2M32	19340320292
M40	UTL-HV32B-SF-1L-M40	19340320253
2M40	UTL-HV32B-SF-1L-2M40	19340320293
PG29	UTL-HV32B-SF-1L-PG29	09340320251
2PG29	UTL-HV32B-SF-1L-2PG29	09340320291
PG36	UTL-HV32B-SF-1L-PG36	09340320252
2PG36	UTL-HV32B-SF-1L-2PG36	09340320292
	带塑料盖 With plastic cover	
M32	UTL-HV32B-SF-1L-CV-M32	19340320257
2M32	UTL-HV32B-SF-1L-CV-2M32	19340320297
M40	UTL-HV32B-SF-1L-CV-M40	19340320258
2M40	UTL-HV32B-SF-1L-CV-2M40	19340320298
PG29	UTL-HV32B-SF-1L-CV-PG29	09340320257
2PG29	UTL-HV32B-SF-1L-CV-2PG29	09340320297
PG36	UTL-HV32B-SF-1L-CV-PG36	09340320258
2PG36	UTL-HV32B-SF-1L-CV-2PG36	09340320298
	带金属盖 With metal cover	
M32	UTL-HV32B-SF-1L-MCV-M32	19340321257
2M32	UTL-HV32B-SF-1L-MCV-2M32	19340321297
M40	UTL-HV32B-SF-1L-MCV-M40	19340321258
2M40	UTL-HV32B-SF-1L-MCV-2M40	19340321298
PG29	UTL-HV32B-SF-1L-MCV-PG29	09340321257
2PG29	UTL-HV32B-SF-1L-MCV-2PG29	09340321297
PG36	UTL-HV32B-SF-1L-MCV-PG36	09340321258
2PG36	UTL-HV32B-SF-1L-MCV-2PG36	09340321298

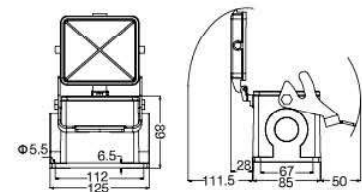



# Metal Hoods & Housings For High Voltage Inserts(HVE Series)

## UTL-HV32B 金属外壳 - 适用高压播芯 (HVE 系列)

**防护等级 Degree of protection: IP65**

上壳 侧出线 Hoods, side entry



螺纹 Thread	型号 Type	订货号 Part Number
M32	UTL-HV32B-SE-4B-M32	19340320527
M40	UTL-HV32B-SE-4B-M40	19340320528
M50	UTL-HV32B-SE-4B-M50	19340320529
PG29	UTL-HV32B-SE-4B-PG29	09340320521
PG36	UTL-HV32B-SE-4B-PG36	09340320522
PG42	UTL-HV32B-SE-4B-PG42	09340320523

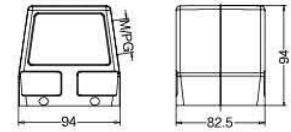

上壳 顶出线 Hoods, top entry



螺纹 Thread	型号 Type	订货号 Part Number
M32	UTL-HV32B-TE-4B-M32	19340320427
M40	UTL-HV32B-TE-4B-M40	19340320428
M50	UTL-HV32B-TE-4B-M50	19340320429
PG29	UTL-HV32B-TE-4B-PG29	09340320421
PG36	UTL-HV32B-TE-4B-PG36	09340320422
PG42	UTL-HV32B-TE-4B-PG42	09340320423

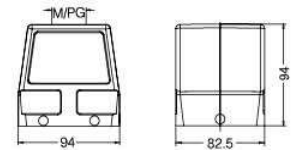

不封底下壳 Housings, bulkhead mounting



螺纹 Thread	型号 Type	订货号 Part Number
---	UTL-HV32B-BK-2L	09340320301

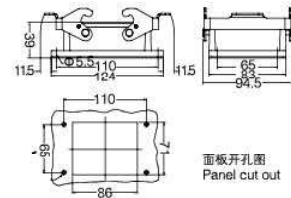

封底下壳 Housings, surface mounting



螺纹 Thread	型号 Type	订货号 Part Number
M32	UTL-HV32B-SF-2L-M32	19340320232
2M32	UTL-HV32B-SF-2L-2M32	19340320272
M40	UTL-HV32B-SF-2L-M40	19340320233
2M40	UTL-HV32B-SF-2L-2M40	19340320273
PG29	UTL-HV32B-SF-2L-PG29	09340320231
2PG29	UTL-HV32B-SF-2L-2PG29	09340320271
PG36	UTL-HV32B-SF-2L-PG36	09340320232
2PG36	UTL-HV32B-SF-2L-2PG36	09340320272
2PG42	UTL-HV32B-SF-2L-2PG42	09340320273

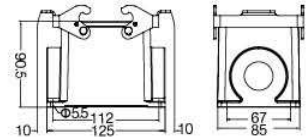

飞线下壳 Housings, cable to cable



螺纹 Thread	型号 Type	订货号 Part Number
M32	UTL-HV32B-CCT-2L-M32	19340320737
M40	UTL-HV32B-CCT-2L-M40	19340320738
PG29	UTL-HV32B-CCT-2L-PG29	09340320731
PG36	UTL-HV32B-CCT-2L-PG36	09340320732
PG42	UTL-HV32B-CCT-2L-PG42	09340320733

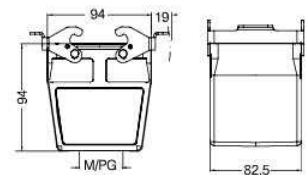

防护盖 Protection covers, metal



螺纹 Thread	型号 Type	订货号 Part Number
---	UTL-HV32B-MCV-4B/2	09340325425

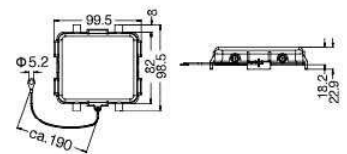

# Metal Hoods & Housings For High Voltage Inserts(HVE Series)

## UTL-HV32B 金属外壳 - 适用高压播芯 (HVE 系列)

**防护等级** Degree of protection: IP65

防护盖 Protection covers, metal



螺纹 Thread	型号 Type	订货号 Part Number
---	UTL-HV32B-MCV-2L.1S	09340325420

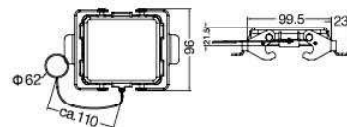

# Metal Hoods & Housings

## 48B 金属外壳

防护等级 Degree of protection: IP65

上壳 侧出线 Hoods, side entry



螺纹 Thread	型号 Type	订货号 Part Number
M32	UTL-H48B-SE-2B-M32	19300480547
M40	UTL-H48B-SE-2B-M40	19300480548
M50	UTL-H48B-SE-2B-M50	19300480549
PG29	UTL-H48B-SE-2B-PG29	09300480540
PG36	UTL-H48B-SE-2B-PG36	09300480541
PG42	UTL-H48B-SE-2B-PG42	09300480542

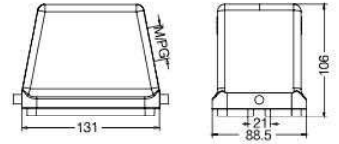

上壳 顶出线 Hoods, top entry



螺纹 Thread	型号 Type	订货号 Part Number
M32	UTL-H48B-TE-2B-M32	19300480447
M40	UTL-H48B-TE-2B-M40	19300480448
M50	UTL-H48B-TE-2B-M50	19300480449
PG29	UTL-H48B-TE-2B-PG29	09300480440
PG36	UTL-H48B-TE-2B-PG36	09300480441
PG42	UTL-H48B-TE-2B-PG42	09300480442

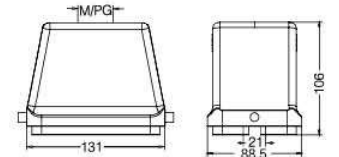

不封底下壳 Housings, bulkhead mounting



螺纹 Thread	型号 Type	订货号 Part Number
---	UTL-H48B-BK-1L	09300480300
	带塑料盖 With plastic cover	
---	UTL-H48B-BK-1L-CV	09300480301
	带金属盖 With metal cover	
---	UTL-H48B-BK-1L-MCV	09300480317

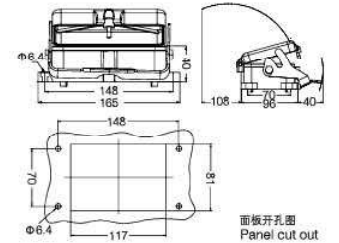

封底下壳 Housings, surface mounting



螺纹 Thread	型号 Type	订货号 Part Number
M32	UTL-H48B-SF-1L-M32	19300480252
2M32	UTL-H48B-SF-1L-2M32	19300480292
M40	UTL-H48B-SF-1L-M40	19300480253
2M40	UTL-H48B-SF-1L-2M40	19300480293
M50	UTL-H48B-SF-1L-M50	19300480254
2M50	UTL-H48B-SF-1L-2M50	19300480294
PG29	UTL-H48B-SF-1L-PG29	09300480250
2PG29	UTL-H48B-SF-1L-2PG29	09300480290
PG36	UTL-H48B-SF-1L-PG36	09300480251
2PG36	UTL-H48B-SF-1L-2PG36	09300480291
	带塑料盖 With plastic cover	
M32	UTL-H48B-SF-1L-CV-M32	19300480257
2M32	UTL-H48B-SF-1L-CV-2M32	19300480297
M40	UTL-H48B-SF-1L-CV-M40	19300480258
2M40	UTL-H48B-SF-1L-CV-2M40	19300480298
PG29	UTL-H48B-SF-1L-CV-PG29	09300480255
2PG29	UTL-H48B-SF-1L-CV-2PG29	09300480295
PG36	UTL-H48B-SF-1L-CV-PG36	09300480256
2PG36	UTL-H48B-SF-1L-CV-2PG36	09300480296
	带金属盖 With metal cover	
M32	UTL-H48B-SF-1L-MCV-M32	19300482257
2M32	UTL-H48B-SF-1L-MCV-2M32	19300482297
M40	UTL-H48B-SF-1L-MCV-M40	19300482258
2M40	UTL-H48B-SF-1L-MCV-2M40	19300482298
PG29	UTL-H48B-SF-1L-MCV-PG29	09300482255
2PG29	UTL-H48B-SF-1L-MCV-2PG29	09300482295
PG36	UTL-H48B-SF-1L-MCV-PG36	09300482256
2PG36	UTL-H48B-SF-1L-MCV-2PG36	09300482296

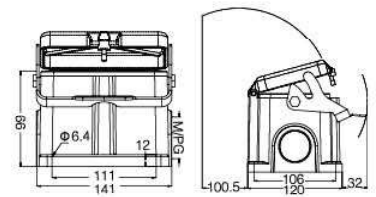

# Metal Hoods & Housings For High Voltage Inserts(HVE Series)

## UTL-HV48B 金属外壳 - 适用高压播芯 (HVE 系列)

**防护等级 Degree of protection: IP65**

上壳 侧出线 Hoods, side entry



螺纹 Thread	型号 Type	订货号 Part Number
M32	UTL-HV48B-SE-2B-M32	19340480547
M40	UTL-HV48B-SE-2B-M40	19340480548
M50	UTL-HV48B-SE-2B-M50	19340480549
PG29	UTL-HV48B-SE-2B-PG29	09340480540
PG36	UTL-HV48B-SE-2B-PG36	09340480541
PG42	UTL-HV48B-SE-2B-PG42	09340480542

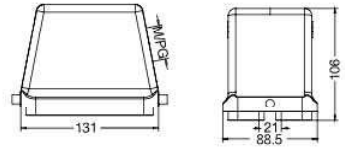

上壳 顶出线 Hoods, top entry



螺纹 Thread	型号 Type	订货号 Part Number
M32	UTL-HV48B-TE-2B-M32	19340480447
M40	UTL-HV48B-TE-2B-M40	19340480448
M50	UTL-HV48B-TE-2B-M50	19340480449
PG29	UTL-HV48B-TE-2B-PG29	09340480440
PG36	UTL-HV48B-TE-2B-PG36	09340480441
PG42	UTL-HV48B-TE-2B-PG42	09340480442

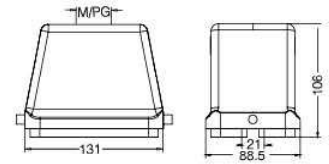

不封底下壳 Housings, bulkhead mounting



螺纹 Thread	型号 Type	订货号 Part Number
---	UTL-HV48B-BK-1L	09340480300
	带塑料盖 With plastic cover	
---	UTL-HV48B-BK-1L-CV	09340480301
	带金属盖 With metal cover	
---	UTL-HV48B-BK-1L-MCV	09340480317

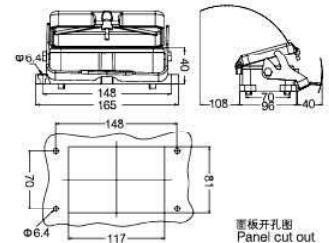

封底下壳 Housings, surface mounting



螺纹 Thread	型号 Type	订货号 Part Number
M32	UTL-HV48B-SF-1L-M32	19340480252
2M32	UTL-HV48B-SF-1L-2M32	19340480292
M40	UTL-HV48B-SF-1L-M40	19340480253
2M40	UTL-HV48B-SF-1L-2M40	19340480293
PG29	UTL-HV48B-SF-1L-PG29	09340480250
2PG29	UTL-HV48B-SF-1L-2PG29	09340480290
PG36	UTL-HV48B-SF-1L-PG36	09340480251
2PG36	UTL-HV48B-SF-1L-2PG36	09340480291
	带塑料盖 With plastic cover	
M32	UTL-HV48B-SF-1L-CV-M32	19340480257
2M32	UTL-HV48B-SF-1L-CV-2M32	19340480297
M40	UTL-HV48B-SF-1L-CV-M40	19340480258
2M40	UTL-HV48B-SF-1L-CV-2M40	19340480298
PG29	UTL-HV48B-SF-1L-CV-PG29	09340480255
2PG29	UTL-HV48B-SF-1L-CV-2PG29	09340480295
PG36	UTL-HV48B-SF-1L-CV-PG36	09340480256
2PG36	UTL-HV48B-SF-1L-CV-2PG36	09340480296
	带金属盖 With metal cover	
M32	UTL-HV48B-SF-1L-MCV-M32	19340482257
2M32	UTL-HV48B-SF-1L-MCV-2M32	19340482297
M40	UTL-HV48B-SF-1L-MCV-M40	19340482258
2M40	UTL-HV48B-SF-1L-MCV-2M40	19340482298
PG29	UTL-HV48B-SF-1L-MCV-PG29	09340482255
2PG29	UTL-HV48B-SF-1L-MCV-2PG29	09340482295
PG36	UTL-HV48B-SF-1L-MCV-PG36	09340482256
2PG36	UTL-HV48B-SF-1L-MCV-2PG36	09340482296

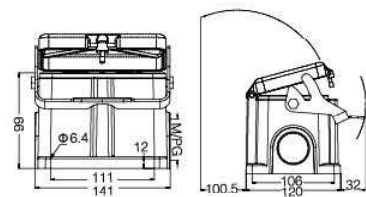

# Plastic Hoods & Housings

## UTL-HC 塑料外壳

**防护等级 Degree of protection: IP65**

上壳 侧出线 Hoods, side entry



螺纹 Thread	型号 Type	订货号 Part Number
PG16	UTL-HC.P-SE-2B-PG16	09120080527

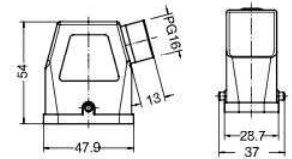

上壳 顶出线 Hoods, top entry



螺纹 Thread	型号 Type	订货号 Part Number
M25	UTL-HC.P-TE-2B-M25	19120080429
PG16	UTL-HC.P-TE-2B-PG16	09120080427
PG21	UTL-HC.P-TE-2B-PG21	09120080429

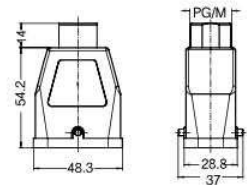

上壳 顶出线 Hoods, top entry



螺纹 Thread	型号 Type	订货号 Part Number
PAFS18	UTL-HC.P-TE-2B-PAFS18	09120080428

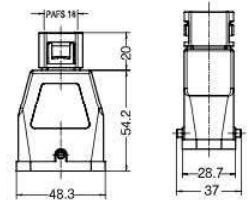

不封底下壳 Housings, bulkhead mounting



螺纹 Thread	型号 Type	订货号 Part Number
---	UTL-HC.P-BK-1L-SE	09120080902

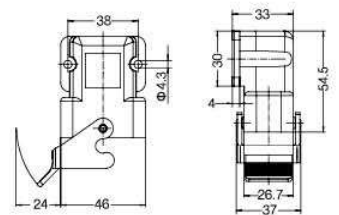

封底下壳 Housings, surface mounting



螺纹 Thread	型号 Type	订货号 Part Number
PG16	UTL-HC.P-SF-1L-PG16	09120080901

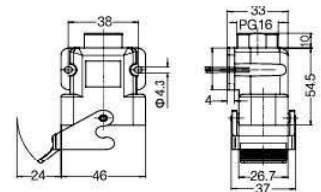

不封底下壳 Housings, bulkhead mounting



螺纹 Thread	型号 Type	订货号 Part Number
---	UTL-HC.P-BK-1L	09120080327

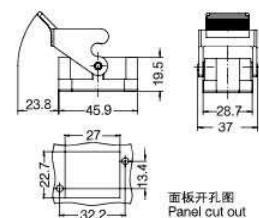

# Plastic Hoods & Housings

## UTL-HC 塑料外壳

**防护等级 Degree of protection: IP65**

飞线下壳 Housings, cable to cable



螺纹 Thread	型号 Type	订货号 Part Number
M25	UTL-HC.P-CCT-1L-M25	19120080729
PG16	UTL-HC.P-CCT-1L-PG16	09120080727

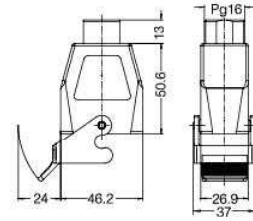

飞线下壳 Housings, cable to cable



螺纹 Thread	型号 Type	订货号 Part Number
PAFS18	UTL-HC.P-CCT-1L-PAFS18	09120080728

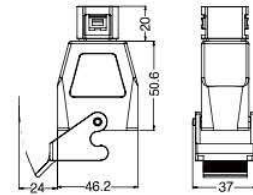

防护盖 Protection covers, metal



螺纹 Thread	型号 Type	订货号 Part Number
---	不带密封圈 Without sealing	
---	UTL-HC.P-CV-2B/1	09120085407
---	带密封圈 With sealing	
---	UTL-HC.P-CV-2B/2	09120085408

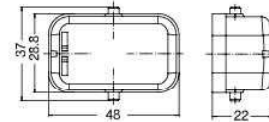

电缆接头 用于上壳 Cable gland, for housings



螺纹 Thread	型号 Type	订货号 Part Number
M25	UTL-WNAPC-M25B(D6.5-9.5)	19120005156
M25	UTL-WNAPC-M25B(D10.5-14)	19120005157
M25	UTL-WNAPC-M25B(D14-17)	19120005158
PG16	UTL-WNAPC-PG16B(D11.5-15.5)	09000005059
PG21	UTL-WNAPC-PG21B(D14-18)	09000005157
PG21	UTL-WNAPC-PG21B(D17-20.5)	09000005158

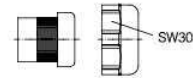

	cable		SW
	min.	max.	
WNAPC-M25B(D6.5-9.5)	6.5 mm	9.5 mm	30
WNAPC-M25B(D10.5-14)	10.5 mm	14 mm	30
WNAPC-M25B(D14-17)	14 mm	17 mm	30
WNAPC-PG16B(D11.5-15.5)	11.5 mm	15.5 mm	27
WNAPC-PG21B(D14-18)	14 mm	18 mm	33
WNAPC-PG21B(D17-20.5)	17 mm	20.5 mm	33

电缆接头 用于上壳 Cable gland, for housings



螺纹 Thread	型号 Type	订货号 Part Number
PG16	UTL-WNAPC-PG16BS(D6.5-9.5)	09000005058
PG16	UTL-WNAPC-PG16BS(D11.5-15.5)	09000005057

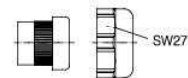

	cable		SW
	min.	max.	
WNAPC-PG16BS(D6.5-9.5)	6.5 mm	9.5 mm	27
WNAPC-PG16BS(D11.5-15.5)	11.5 mm	15.5 mm	27

# Metal Hoods & Housings

## UTL-HC 金属外壳

喷涂 Epoxy power paint 防护等级 Degree of protection: IP65

上壳 侧出线 Hoods, side entry



螺纹 Thread	型号 Type	订货号 Part Number
M25	UTL-HC-SE-2B-M25	19127080501

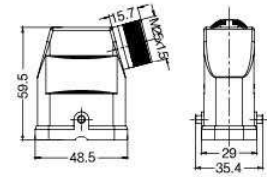

上壳 侧出线 高结构 上下分体式 Hoods, side entry, high construction



螺纹 Thread	型号 Type	订货号 Part Number
M25	UTL-HC-SEH-2B-M25	19127080511

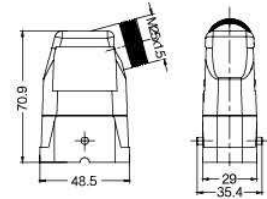

上壳 顶出线 高结构 上下分体式 Hoods, top entry, high construction



螺纹 Thread	型号 Type	订货号 Part Number
M25	UTL-HC-TEH-2B-M25	19127080411

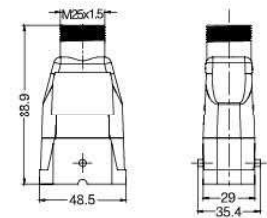

上壳 侧出线 高结构 合盖式 Hoods, side entry, high construction



螺纹 Thread	型号 Type	订货号 Part Number
M25	UTL-HC-SEHS-2B-M25	19120080526

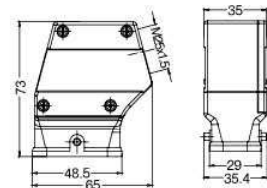

上壳 顶出线 高结构 合盖式 Hoods, top entry, high construction



螺纹 Thread	型号 Type	订货号 Part Number
M25	UTL-HC-TEHS-2B-M25	19120080426

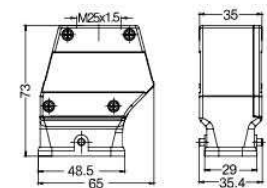

不封底下壳 Housings, bulkhead mounting



螺纹 Thread	型号 Type	订货号 Part Number
---	UTL-HC-BK-1L/S	09127080301

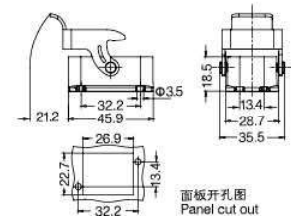

# Metal Hoods & Housings

## UTL-HC 金属外壳

喷涂 Epoxy power paint 防护等级 Degree of protection: IP65

防护盖 Protection covers, metal



螺纹 Thread	型号 Type	订货号 Part Number
	不带密封圈 Without sealing	
---	UTL-HC-MCV-2B/1	09120085409
	带密封圈 With sealing	
---	UTL-HC-MCV-2B/2	09120085410

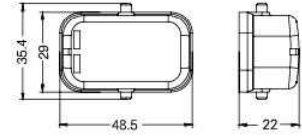

电缆接头 用于上壳 Cable gland, for housings



螺纹 Thread	型号 Type	订货号 Part Number
M25	UTL-WNAMC-M25(D10.5-14)	19120005057
M25	UTL-WNAMC-M25(D14-17)	19120005058

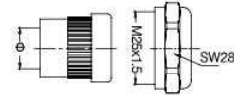

	Φ(线径)	cable		SW
		min.	max.	
WNAMC-M25	10.5-14	10.5 mm	14 mm	28
WNAMC-M25	14-17	14 mm	17 mm	28



# Metal Hoods & Housings

## UTL-HC 金属外壳

镀铬 Chromated 防护等级 Degree of protection: IP65

上壳 侧出线 Hoods, side entry



螺纹 Thread	型号 Type	订货号 Part Number
M25	UTL-C.HC-SE-2B-M25	19120080501

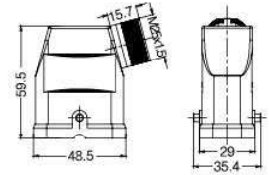

上壳 侧出线 高结构 上下分体式 Hoods, side entry, high construction



螺纹 Thread	型号 Type	订货号 Part Number
M25	UTL-C.HC-SEH-2B-M25	19120080511

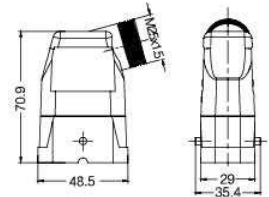

上壳 顶出线 高结构 上下分体式 Hoods, top entry, high construction



螺纹 Thread	型号 Type	订货号 Part Number
M25	UTL-C.HC-TEH-2B-M25	19120080411

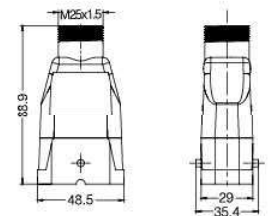

上壳 侧出线 高结构 合盖式 Hoods, side entry, high construction



螺纹 Thread	型号 Type	订货号 Part Number
M25	UTL-C.HC-SEHS-2B-M25	19120080527

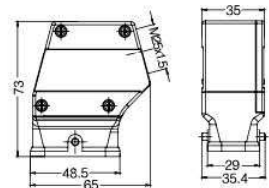

上壳 顶出线 高结构 合盖式 Hoods, top entry, high construction



螺纹 Thread	型号 Type	订货号 Part Number
M25	UTL-C.HC-TEHS-2B-M25	19120080427

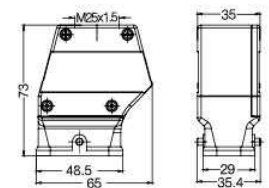

不封底下壳 Housings, bulkhead mounting



螺纹 Thread	型号 Type	订货号 Part Number
---	UTL-C.HC-BK-1L/S	09120080301

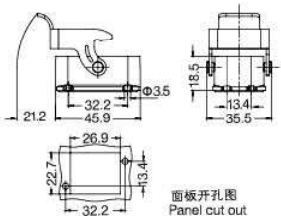

# Metal Hoods & Housings

## UTL-HC 金属外壳

镀铬 Chromated 防护等级 Degree of protection: IP65

防护盖 Protection covers, metal



螺纹 Thread	型号 Type	订货号 Part Number
---	不带密封圈 Without sealing	
---	UTL-C.HC-MCV-2B/1	09120085411
---	带密封圈 With sealing	
---	UTL-C.HC-MCV-2B/2	09120085412

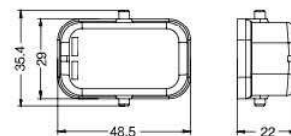

电缆接头 用于上壳 Cable gland, for housings



螺纹 Thread	型号 Type	订货号 Part Number
M25	UTL-WNAMC-M25(D10 5-14)	19120005057
M25	UTL-WNAMC-M25(D14-17)	19120005058

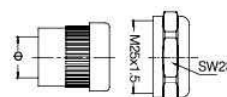

	Φ(线径)	cable		SW
		min.	max.	
WNAMC-M25	10.5-14	10.5 mm	14 mm	28
WNAMC-M25	14-17	14 mm	17 mm	28

# Metal Hoods & Housings(EMC)

## UTL-HC 金属外壳 (EMC)

镀镍 Nickel plating 防护等级 Degree of protection: IP65

上壳 侧出线 Hoods, side entry



螺纹 Thread	型号 Type	订货号 Part Number
M25	UTL-EMC.HC-SE-2B-M25	19120080502

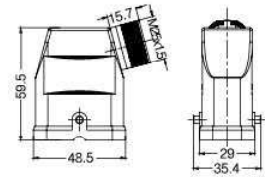

上壳 侧出线 高结构 上下分体式 Hoods, side entry, high construction



螺纹 Thread	型号 Type	订货号 Part Number
M25	UTL-EMC.HC-SEH-2B-M25	19120080512

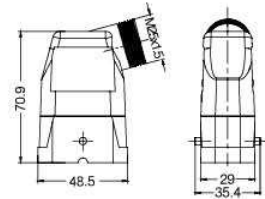

上壳 顶出线 高结构 上下分体式 Hoods, top entry, high construction



螺纹 Thread	型号 Type	订货号 Part Number
M25	UTL-EMC.HC-TEH-2B-M25	19120080412

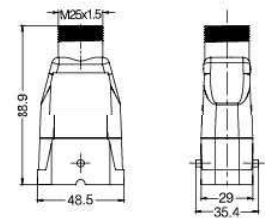

上壳 侧出线 高结构 合盖式 Hoods, side entry, high construction



螺纹 Thread	型号 Type	订货号 Part Number
M25	UTL-EMC.HC-SEHS-2B-M25	19120080528

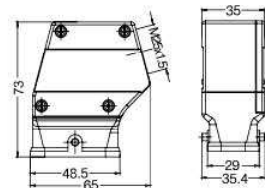

上壳 顶出线 高结构 合盖式 Hoods, top entry, high construction



螺纹 Thread	型号 Type	订货号 Part Number
M25	UTL-EMC.HC-TEHS-2B-M25	19120080428

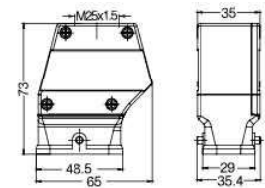

不封底下壳 Housings, bulkhead mounting



螺纹 Thread	型号 Type	订货号 Part Number
---	UTL-EMC.HC-BK-1L/S	09120080303

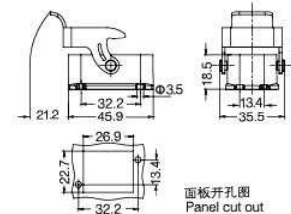

# Metal Hoods & Housings(EMC)

## UTL-HC 金属外壳 (EMC)

镀镍 Nickel plating 防护等级 Degree of protection: IP65

防护盖 Protection covers, metal



螺纹 Thread	型号 Type	订货号 Part Number
	不带密封圈 Without sealing	
---	UTL-EMC.HC-MCV-2B/1	09120085413
	带密封圈 With sealing	
---	UTL-EMC.HC-MCV-2B/2	09120085414

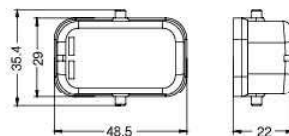

电缆接头 用于上壳 Cable gland, for housings



螺纹 Thread	型号 Type	订货号 Part Number
M25	UTL-WNAMC-M25(D10.5-14)	19120005057
M25	UTL-WNAMC-M25(D14-17)	19120005058

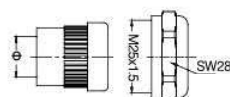

	Ø(线径)	cable		SW
		min.	max.	
WNAMC-M25	10.5-14	10.5 mm	14 mm	28
WNAMC-M25	14-17	14 mm	17 mm	28

# Crimp contacts

## 冷压针

### 5A冷压接插针(适用于UTL-HM,UTL-EMC-008,UTL-D-SUB,插芯)

5A Crimp contacts (for UTL-HM,UTL-EMC- 008,UTL-D- SUB, inserts)

接触电阻  $\leq 3\Omega$  Contact resistance  $\leq 3m\Omega$

镀银  
silver plated



镀金  
gold plated



公 Male	订货号 Part Number	母 Female	订货号 Part Number
CSSM-0.25	61030000178	CSSF-0.25	61030000180
CSSM-0.33	61030000194	CSSF-0.33	61030000196
CSSM-0.52	61030000173	CSSF-0.52	61030000174
CSSM-0.82	61030000182	CSSF-0.82	61030000184
CSGM-0.25	61030000078	CSGF-0.25	61030000080
CSGM-0.33	61030000094	CSGF-0.33	61030000096
CSGM-0.52	61030000073	CSGF-0.52	61030000074
CSGM-0.82	61030000082	CSGF-0.82	61030000084

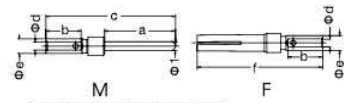

a	b	c	d	e	f
8.23	4.2	14.0	1.35	1.75	13.6
8.10	4.0	14.8	1.12	1.66	14.4
8.10	4.0	14.8	0.90	1.66	14.4
8.10	4.0	14.8	0.64	1.66	14.4

线规 Wire gauge	剥线长度 Stripping length	
0.09-0.25 mm <sup>2</sup>	AWG 28-24	5 mm
0.13-0.33 mm <sup>2</sup>	AWG 26-22	5 mm
0.33-0.52 mm <sup>2</sup>	AWG 22-20	5 mm
0.33-0.82 mm <sup>2</sup>	AWG 22-18	5 mm

### 10A冷压接插针(适用于UTL-HD,UTL-HDD,UTL-HM,UTL-HK,UTL-HQ插芯)

10A Crimp contacts (for UTL-HD,UTL-HDD,UTL-HM,UTL-HK,UTL-HQ inserts)

接触电阻  $\leq 3m\Omega$  Contact resistance  $\leq 3m\Omega$

镀银  
silver plated



镀金  
gold plated



公 Male	订货号 Part Number	母 Female	订货号 Part Number
CDSM-0.37	09150006104	CDSF-0.37	09150006204
CDSM-0.5	09150006103	CDSF-0.5	09150006203
CDSM-0.75	09150006105	CDSF-0.75	09150006205
CDSM-1.0	09150006102	CDSF-1.0	09150006202
CDSM-1.5	09150006101	CDSF-1.5	09150006201
CDSM-2.5	09150006106	CDSF-2.5	09150006206

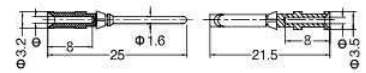

线规 Wire gauge	Φ	剥线长度 Stripping length	
0.14-0.37 mm <sup>2</sup>	AWG 26-22	0.9	8 mm
0.5 mm <sup>2</sup>	AWG 20	1.1	8 mm
0.75 mm <sup>2</sup>	AWG 18	1.3	8 mm
1 mm <sup>2</sup>	AWG 18	1.45	8 mm
1.5 mm <sup>2</sup>	AWG 16	1.75	8 mm
2.5 mm <sup>2</sup>	AWG 14	2.25	6 mm

### 10A压簧冷压接插针,带两爪支撑(适用于UTL-HD,UTL-HDD,UTL-HM,UTL-HK,UTL-HQ插芯)

10A take two claws support (for UTL-HD,UTL-HDD,UTL-HM,UTL-HK,UTL-HQ inserts)

接触电阻  $\leq 3m\Omega$  Contact resistance  $\leq 3m\Omega$

镀银  
silver plated



镀金  
gold plated



公 Male	订货号 Part Number	母 Female	订货号 Part Number
CDSM-0.37B	09150006304	CDSF-0.37B	09150006404
CDSM-0.5B	09150006303	CDSF-0.5B	09150006403
CDSM-0.75B	09150006305	CDSF-0.75B	09150006405
CDSM-1.0B	09150006302	CDSF-1.0B	09150006402
CDSM-1.5B	09150006301	CDSF-1.5B	09150006401
CDSM-2.5B	09150006306	CDSF-2.5B	09150006406

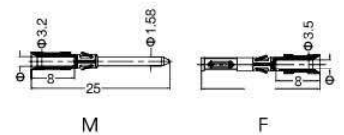

线规 Wire gauge	Φ	剥线长度 Stripping length	
0.14-0.37 mm <sup>2</sup>	AWG 26-22	0.9	8 mm
0.5 mm <sup>2</sup>	AWG 20	1.1	8 mm
0.75 mm <sup>2</sup>	AWG 18	1.3	8 mm
1 mm <sup>2</sup>	AWG 18	1.45	8 mm
1.5 mm <sup>2</sup>	AWG 16	1.75	8 mm
2.5 mm <sup>2</sup>	AWG 14	2.25	6 mm

# Crimp contacts

## 冷压针

### 10A冷压接插针, 带三爪支撑(适用于UTL-HD,UTL-HDD,UTL-HM,UTL-HK,UTL-HQ插芯)

10A Crimp contactstake three claws support (for UTL-HD,UTL-HDD,UTL-HM,UTL-HK,UTL-HQ inserts)

接触电阻 ≤ 3mΩ Contact resistance ≤ 3mΩ

	公 Male	订货号 Part Number	母 Female	订货号 Part Number
镀银 silver plated	ZCDSM-0.37	09150006504	ZCDSF-0.37	09150006604
	ZCDSM-0.5	09150006503	ZCDSF-0.5	09150006603
	ZCDSM-0.75	09150006505	ZCDSF-0.75	09150006605
	ZCDSM-1.0	09150006502	ZCDSF-1.0	09150006602
	ZCDSM-1.5	09150006501	ZCDSF-1.5	09150006601
	ZCDSM-2.5	09150006506	ZCDSF-2.5	09150006606
镀金 gold plated	ZCDGM-0.37	09150006524	ZCDGF-0.37	09150006624
	ZCDGM-0.5	09150006523	ZCDGF-0.5	09150006623
	ZCDGM-0.75	09150006525	ZCDGF-0.75	09150006625
	ZCDGM-1.0	09150006522	ZCDGF-1.0	09150006622
	ZCDGM-1.5	09150006521	ZCDGF-1.5	09150006621
	ZCDGM-2.5	09150006526	ZCDGF-2.5	09150006626

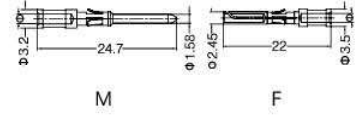

标识 Identification	线规 Wire gauge	Φ	剥线长度 Stripping length
no groove	0.14-0.37 mm <sup>2</sup>	AWG 26-22	0.9
no groove	0.5 mm <sup>2</sup>	AWG 20	1.1
1 groove	0.75 mm <sup>2</sup>	AWG 18	1.3
1 groove	1 mm <sup>2</sup>	AWG 18	1.45
1.5 mm <sup>2</sup>	AWG 16	1.75	8 mm
2.5 mm <sup>2</sup>	AWG 14	2.25	6 mm

### 16A冷压接插针(适用于UTL-HA,UTL-HE,UTL-HEE,UTL-HM,UTL-HK插芯)

16A Crimp contacts (for UTL-HA,UTL-HE,UTL-HEE,UTL-HM,UTL-HK inserts)

接触电阻 ≤ 1mΩ Contact resistance ≤ 1mΩ

	公 Male	订货号 Part Number	母 Female	订货号 Part Number
镀银 silver plated	CESM-0.37	09330006127	CESF-0.37	09330006227
	CESM-0.5	09330006121	CESF-0.5	09330006220
	CESM-0.75	09330006114	CESF-0.75	09330006214
	CESM-1.0	09330006105	CESF-1.0	09330006205
	CESM-1.5	09330006104	CESF-1.5	09330006204
	CESM-2.5	09330006102	CESF-2.5	09330006202
镀金 gold plated	CESM-3.0	09330006106	CESF-3.0	09330006206
	CESM-4.0	09330006107	CESF-4.0	09330006207
	CEGM-0.37	09330006117	CEGF-0.37	09330006217
	CEGM-0.5	09330006122	CEGF-0.5	09330006222
	CEGM-0.75	09330006115	CEGF-0.75	09330006215
	CEGM-1.0	09330006118	CEGF-1.0	09330006218
	CEGM-1.5	09330006116	CEGF-1.5	09330006216
	CEGM-2.5	09330006123	CEGF-2.5	09330006223
CEGM-4.0	09330006119	CEGF-4.0	09330006221	

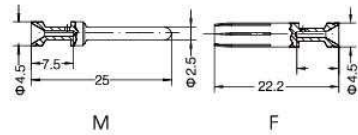

标识 Identification	线规 Wire gauge	剥线长度 Stripping length
no groove	0.14-0.37 mm <sup>2</sup>	AWG 26-22
no groove	0.5 mm <sup>2</sup>	AWG 20
1 groove	0.75 mm <sup>2</sup>	AWG 18
1 groove	1 mm <sup>2</sup>	AWG 18
2 groove	1.5 mm <sup>2</sup>	AWG 16
3 groove	2.5 mm <sup>2</sup>	AWG 14
wide groove	3 mm <sup>2</sup>	AWG 12
no groove	4 mm <sup>2</sup>	AWG 12

### 16A冷压接插针(采用冠簧接触)(适用于UTL-HA,UTL-HE,UTL-HEE,UTL-HM,UTL-HK)

16A Crimp contacts (with crown contact) (for UTL-HA,UTL-HE,UTL-HEE,UTL-HM,UTL-HK inserts)

接触电阻 ≤ 1mΩ Contact resistance ≤ 1mΩ

	公 Male	订货号 Part Number	母 Female	订货号 Part Number
镀银 silver plated	CESM-0.37	09330006327	CESF-0.37G	09330006427
	CESM-0.5	09330006321	CESF-0.5G	09330006420
	CESM-0.75	09330006314	CESF-0.75G	09330006414
	CESM-1.0	09330006305	CESF-1.0G	09330006405
	CESM-1.5	09330006304	CESF-1.5G	09330006404
	CESM-2.5	09330006302	CESF-2.5G	09330006402
镀金 gold plated	CESM-3.0	09330006306	CESF-3.0G	09330006406
	CESM-4.0	09330006307	CESF-4.0G	09330006407
	CEGM-0.37	09330006317	CEGF-0.37G	09330006417
	CEGM-0.5	09330006322	CEGF-0.5G	09330006422
	CEGM-0.75	09330006315	CEGF-0.75G	09330006415
	CEGM-1.0	09330006318	CEGF-1.0G	09330006418
	CEGM-1.5	09330006316	CEGF-1.5G	09330006416
	CEGM-2.5	09330006323	CEGF-2.5G	09330006423
CEGM-4.0	09330006319	CEGF-4.0G	09330006421	

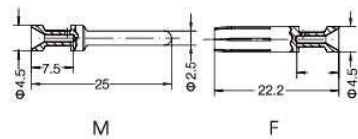

标识 Identification	线规 Wire gauge	剥线长度 Stripping length
no groove	0.14-0.37 mm <sup>2</sup>	AWG 26-22
no groove	0.5 mm <sup>2</sup>	AWG 20
1 groove	0.75 mm <sup>2</sup>	AWG 18
1 groove	1 mm <sup>2</sup>	AWG 18
2 groove	1.5 mm <sup>2</sup>	AWG 16
3 groove	2.5 mm <sup>2</sup>	AWG 14
wide groove	3 mm <sup>2</sup>	AWG 12
no groove	4 mm <sup>2</sup>	AWG 12

# Crimp contacts

## 冷压针

### 40A冷压接插针(适用于UTL-HM,UTL-HK等插芯)

#### 40A Crimp contacts (for UTL-HM,UTL-HK inserts)

接触电阻  $\leq 0.3m\Omega$  Contact resistance  $\leq 0.3m\Omega$

镀银  
silver plate



镀金  
gold plated



公 Male	订货号 Part Number	母 Female	订货号 Part Number
CCSM-1.5	09320006104	CCSF-1.5	09320006204
CCSM-2.5	09320006105	CCSF-2.5	09320006205
CCSM-4.0	09320006107	CCSF-4.0	09320006207
CCSM-6.0	09320006108	CCSF-6.0	09320006208
CCSM-10.0	09320006109	CCSF-10.0	09320006209
CCGM-1.5	09320006304	CCGF-1.5	09320006404
CCGM-2.5	09320006305	CCGF-2.5	09320006405
CCGM-4.0	09320006307	CCGF-4.0	09320006407
CCGM-6.0	09320006308	CCGF-6.0	09320006408
CCGM-10.0	09320006309	CCGF-10.0	09320006409

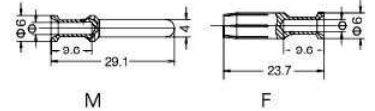

线规 Wire gauge	$\Phi$	剥线长度 Stripping length
1.5 mm <sup>2</sup> AWG 16	1.75	9 mm
2.5 mm <sup>2</sup> AWG 14	2.25	9 mm
4 mm <sup>2</sup> AWG 12	2.85	9.6 mm
6 mm <sup>2</sup> AWG 10	3.5	9.6 mm
10 mm <sup>2</sup> AWG 8	4.3	15 mm

### 70A冷压接插针(适用于UTL-HM等插芯)

#### 70A Crimp contacts (for UTL-HM inserts)

接触电阻  $\leq 0.5m\Omega$  Contact resistance  $\leq 0.5m\Omega$

镀银  
silver plated



公 Male	订货号 Part Number	母 Female	订货号 Part Number
CKSM70-10	09320007104	CKSF70-10	09320007204
CKSM70-16	09320007105	CKSF70-16	09320007205
CKSM70-25	09320007106	CKSF70-25	09320007206

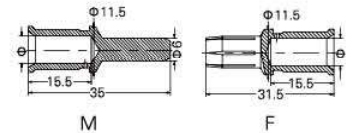

线规 Wire gauge	$\Phi$	剥线长度 Stripping length
10 mm <sup>2</sup>	4.3	15.5 mm
16 mm <sup>2</sup>	5.5	15.5 mm
25 mm <sup>2</sup>	7	15.5 mm

电缆绞线依据 IEC 60 228-5

### 100A冷压接插针(采用冠簧接触)(适用于UTL-HM,UTL-HK插芯)

#### 100A Crimp contacts (with crown contact) (for UTL-HM,UTL-HK insert)

接触电阻  $\leq 0.3m\Omega$  Contact resistance  $\leq 0.3m\Omega$

镀银  
silver plated



公 Male	订货号 Part Number	母 Female	订货号 Part Number
CKSM-10	09110006114	CKSF-10G	09110006214
CKSM-16	09110006116	CKSF-16G	09110006216
CKSM-25	09110006125	CKSF-25G	09110006225
CKSM-35	09110006135	CKSF-35G	09110006235
		开槽结构 Slot structure	
		CKSF-10	09110006414
		CKSF-16	09110006416
		CKSF-25	09110006425
		CKSF-35	09110006435

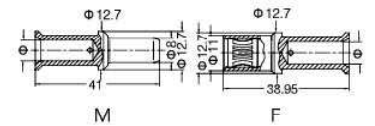

线规 Wire gauge	$\Phi$	剥线长度 Stripping length
10 mm <sup>2</sup>	4.3	19 mm
16 mm <sup>2</sup>	5.5	19 mm
25 mm <sup>2</sup>	7	19 mm
35 mm <sup>2</sup>	8.2	16 mm

电缆绞线依据 IEC 60 228-5

# Crimp contacts

## 冷压针

### 200A冷压接插针(适用于UTL-HM插芯)

#### 200A Crimp contacts (for UTL-HM inserts)

接触电阻 $\leq 0.3m\Omega$  Contact resistance $\leq 0.3m\Omega$

镀银  
silver plated



公 Male	订货号 Part Number	母 Female	订货号 Part Number
CHSM200-25	09110006120	CHSF200-25	09110006220
CHSM200-35	09110006121	CHSF200-35	09110006221
CHSM200-50	09110006122	CHSF200-50	09110006222
CHSM200-70	09110006123	CHSF200-70	09110006223

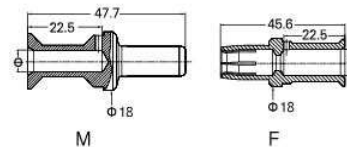

导线截面 Wire gauge	$\Phi$	刺线长度 刺线长度 length
25 mm <sup>2</sup>	7	22.5 mm
35 mm <sup>2</sup>	8.2	22.5 mm
50 mm <sup>2</sup>	10	22.5 mm
70 mm <sup>2</sup>	11.5	22.5 mm

电缆绞线依据 IEC 60 228-5-

### 保险延迟针

#### Relay contact

镀银  
silver plated



线规(mm <sup>2</sup> ) Wire gauge(mm <sup>2</sup> )	型号 Designation	订货号 Part Number
1.0	UTL-CESM-1.0R	09330006109
1.5	UTL-CESM-1.5R	09330006110
2.5	UTL-CESM-2.5R	09330006111

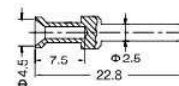



# Coding 编码

## 用编码销编号 Coding system with code pins

编码销  
Code pin



型号 Designation	订货号 Part Number
UTL-CODE-M3	0930009901

模块型编码销  
Modular code pin



UTL-MCODE-M3	09140009901
--------------	-------------

编码销:  
Code pin:

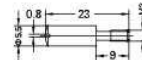

模块型编码销:  
Modular code pin:

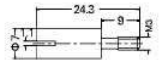

适用于可安装一个插芯或框架的外壳  
for hoods housings with one insert one frame

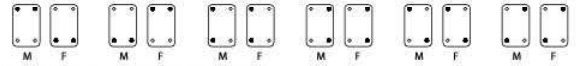

适用于可安装两个插芯或框架的外壳  
for hoods housings with two inserts two frames

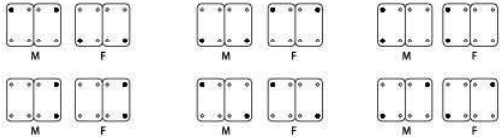

● 编码销  
Code pin  
○ 正常螺丝  
Normal mounting screw

M-公插芯  
M-Male insert  
F-母插芯  
F-Female insert

## 用导向销和导向孔编号 Coding system with guide pins bushes

导向孔  
Guide bush



型号 Designation	订货号 Part Number
UTL-GBUSH-M3	09330009909

导向销  
Guide pin



UTL-GPIN-M3	09330009908
-------------	-------------

模块型导向孔  
Modular guide bush



UTL-MGBUSH-M3	09140009909
---------------	-------------

模块型导向销  
Modular guide pin



UTL-MGPIN-M3	09140009908
--------------	-------------

导向孔  
Guide bush

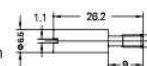

模块型导向孔  
Modular guide bush

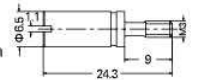

导向销  
Guide pin



模块型导向销  
Modular guide pin

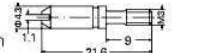

适用于可安装一个插芯或框架的外壳  
for hoods housings with one insert one frame

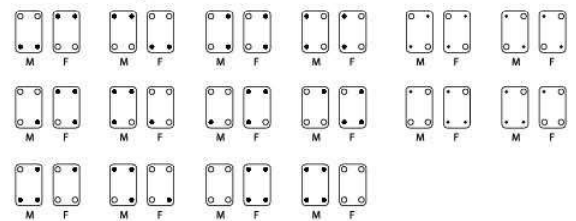

适用于可安装两个插芯或框架的外壳  
for hoods housings with two inserts two frames

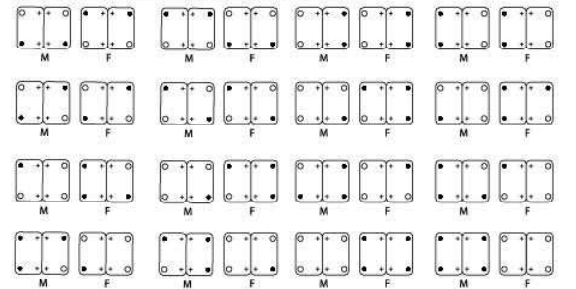

● 导向孔  
Guide pin  
○ 导向销  
Bush  
+ 正常螺丝  
Normal mounting screw

M-公插芯  
M-Male insert  
F-母插芯  
F-Female insert

# Coding 编码

## 编码 Coding

编码销 Code pin

型号 Designation	订货号 Part Number
UTL-CODE-E	09330009954



- ① 使用此编码销,可避免相同连接器的误插
  - ② 适用于HEC,HEE,HE-5/0,HM-006,HM-008
  - ③ 使用编码销时,公插对应孔不能装插针
- ① Use of the coding pin prevents incorrect mating to other connectors of the same type.
  - ② For HEC,HEE,HE-5/0,HM-006,HM-008
  - ③ The male pin should be omitted from the opposing cavity in the male insert.

编码销 Code pin

型号 Designation	订货号 Part Number
UTL-CODE-D	09330009915

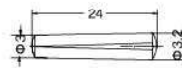

- ① 使用此编码销,可避免相同连接器的误插
  - ② 适用于HD,HDD,HMD-012, HMDD-017, HQ-7/0, HQ-012/0
  - ③ 使用编码销时,公插对应孔不能装插针
- ① Use of the coding pin prevents incorrect mating to other connectors of the same type.
  - ② For HD,HDD,HMD-012, HMDD-017, HQ-7/0, HQ-012/0
  - ③ The male pin should be omitted from the opposing cavity in the male insert.

滚花螺栓 Screw pin

型号 Designation	订货号 Part Number
UTL-GH-M4	09330009910

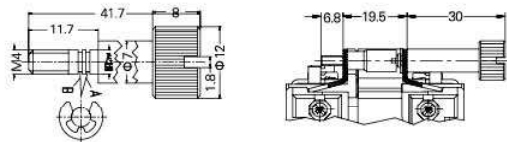

套筒螺栓 Screw bash

型号 Designation	订货号 Part Number
UTL-GHT-M3	09330009912

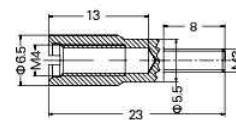

# Accessories/frame 附件 / 框架

## 安装架 Mounting

用于H version  
for H version housings



规格 Size	型号 Designation	订货号 Part Number
6B	UTL-HP6B-MF	09400009921
10B	UTL-HP10B-MF	09400009922
16B	UTL-HP16B-MF	09400009923
24B	UTL-HP24B-MF	09400009924

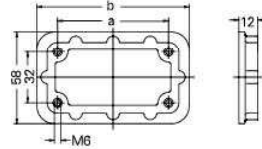

规格 Size	a	b
6B	70	96
10B	83	109
16B	103	129
24B	130	156

## 对接架 Docking frame



规格 Size	型号 Designation	订货号 Part Number
6B	UTL-H6B-ADK	09300061701
10B	UTL-H10B-ADK	09300101701
16B	UTL-H16B-ADK	09300161701
24B	UTL-H24B-ADK	09300241701

技术参数 Technical characteristics  
 材料 Material 不锈钢  
 - 对接架 Docking frame stainless steel  
 - 固定螺栓 Fixing screws 铁, 镀锌 steel, zinc-plated

插入容差 Pull-in-range  
 - x轴 x-axis  $\pm 1.5\text{mm}$   
 - y轴 y-axis  $\pm 1.5\text{mm}$   
 拔插次数 Mechanical working life  $\geq 500$

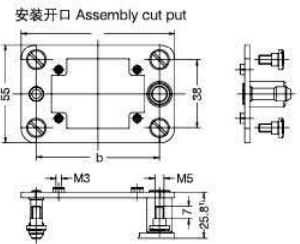

1) 距离 电气针和光电线缆距离最大27mm  
 气动针距离最大26.5mm  
 Distance for electrical and F.O. contacts max. 27 mm; for pneumatic contacts max. 26.5 mm

产品包括 Range of delivery:

1个架子 1 frame  
 4个带平头的螺栓, 用于固定对接架  
 4 cheese head shoulder screws  
 to fix the docking frame

规格 Size	a	b	c	d	e
6B	86	69	69	54.5	84
10B	99	82	82	67.5	97
16B	119.5	102.5	102.5	88	117.5
24B	146	129	129	114.5	144

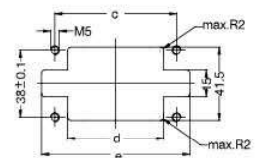

### 退针器 Contact removal tools

D-Sub 退针器 D-sub Contact removal tool



适用范围Application	型号Designation	订货号 Part Number
5A 冷压针 for 5A crimp contacts	UTL-TL08	09990000368

HD 退针器 HD Contact removal tool



适用范围Application	型号Designation	订货号 Part Number
10A 冷压针 for 10A crimp contacts	UTL-TL00	09990000012
16A带三爪的公插针 16A male contacts (take three claws support)		

HEE 退针器 HEE Contact removal tool



适用范围Application	型号Designation	订货号 Part Number
16A 冷压针 16A crimp contacts	UTL-TL01	09990000319

HEE 退针器 HEE Contact removal tool



适用范围Application	型号Designation	订货号 Part Number
16A带三爪的母插针 16A female contacts (take three claws support)	UTL-TL09	09990000328

C型 退针器 Contact removal tool



适用范围Application	型号Designation	订货号 Part Number
40A 冷压针 40A crimp contacts	UTL-TL06G	09990000305

K型 退针器 Contact removal tool



适用范围Application	型号Designation	订货号 Part Number
H2MK-002插芯inserts	UTL-TL07	09990000383
HMK-001插芯inserts		

送针器 Insertion Tool



适用范围Application	型号Designation	订货号 Part Number
10A/16A辅助装针工具 Insertion tool for crimp contacts	UTL-TL15	09990000059

# Tools 工具

## 压接工具 Crimping tools

5A 冷压钳 5A Crimping tool



压接线径 Wire gauge	型号 Designation	订货号 Part Number
0.09-0.82mm <sup>2</sup>	UTL-TL03	09990000001

10A/16A/40A 冷压钳 10A/16A/40A Crimping tool



压接线径 Wire gauge	型号 Designation	订货号 Part Number
0.14-4mm <sup>2</sup>	UTL-TL02G	09990000021
1.5-6mm <sup>2</sup>	UTL-TL02-0G	09990000110
4/6/10mm <sup>2</sup>	UTL-TL02-3G	09990000303

100A/650A 大电流手动液压钳 100A/650A manual hydraulic clamp



描述 Description	压接线径 Wire gauge	型号 Designation	订货号 Part Number
出力: 自动泄压 Output: automatic pressure release	10-240mm <sup>2</sup>	UTL-TL05	09990000385
出力: 13T Output: 13T			
重量: 6.2kg Weight: 6.2kg			

# Cable glands

## 电缆接头

### 普通金属防水电缆接头 Plastic cable gland

材料: 黄铜镀镍	Material: Nickel-plate brass
密封件: 尼龙6和丁晴橡胶	Sealing: Nylon and NBR
防护等级: IP68(要使用O型圈的情况下)	Degree of protection: IP68(with O-sealing)
温度范围: 静态: -40°C...+100°C	Temperature range: Stat: -40°C...+100°C
动态: -20°C...+80°C	Dyn: -20°C...+80°C

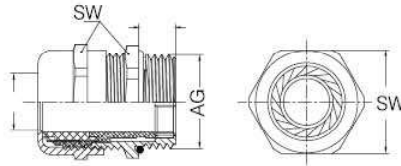

单位: mm  
Unit: mm

螺纹尺寸 Thread size	卡口范围(Φ) Clamping range(Φ)	螺纹外径(AG) Thread diameter(AG)	扳手尺寸(SW) Wrench size(SW)	螺纹长度(GL) Thread length GL	型号 Designation	订货号 Order NO.
<b>PG制螺纹</b> PG Thread						
PG7	3-6.5	12.5	14	6	UTL-WNA-PG7(D3-6.5)	09000000110
PG9	4-8	15.2	17	6.5	UTL-WNA-PG9(D4-8)	09000000111
PG11	5-10	18.6	20	7	UTL-WNA-PG11(D5-10)	09000000112
PG13.5	6-12	20.4	22	7.5	UTL-WNA-PG13.5(D6-12)	09000000113
PG16	8-14	22.5	24	7	UTL-WNA-PG16(8-14)	09000000114
PG21	13-18	28.3	30	8	UTL-WNA-PG21(D13-18)	09000000115
PG29	18-25	37.0	40	9	UTL-WNA-PG29(D18-25)	09000000116
PG36	22-32	47.0	50	12	UTL-WNA-PG36(D22-32)	09000000117
PG42	31-38	54.0	57	12	UTL-WNA-PG42(D31-38)	09000000118
PG48	37-44	59.3	65	12	UTL-WNA-PG48(D37-44)	09000000119
<b>M公制螺纹</b> Metric Thread						
M12x1.5	3-6.5	12	14	6	UTL-WNA-M12(D3-6.5)	19000000110
M14x1.5	3-6.5	14	14	6	UTL-WNA-M14(D3-6.5)	19000000111
M16x1.5	4-8	16	17	6.5	UTL-WNA-M16(D4-8)	19000000112
M16x1.5	5-10	16	20	6	UTL-WNA-M16(D5-10)	19000000113
M16x1.5	5-10	18	20	7	UTL-WNA-M18(D5-10)	19000000114
M20x1.5	6-12	20	22	8	UTL-WNA-M20(D6-12)	19000000115
M20x1.5	8-14	20	24	8	UTL-WNA-M20(D8-14)	19000000116
M22x1.5	8-14	22	24	7.5	UTL-WNA-M22(D8-14)	19000000117
M25x1.5	9-16	25	27	7.5	UTL-WNA-M25(D9-16)	19000000118
M25x1.5	13-18	25	30	7.5	UTL-WNA-M25(D13-18)	19000000119
M32x1.5	15-22	32	35	8.5	UTL-WNA-M32(D15-22)	19000000120
M32x1.5	18-25	32	40	8.0	UTL-WNA-M32(D18-25)	19000000121
M40x1.5	18-25	40	45	12	UTL-WNA-M40(D18-25)	19000000122
M40x1.5	22-32	40	50	12	UTL-WNA-M40(D22-32)	19000000123
M50x1.5	22-32	50	57	12	UTL-WNA-M50(D22-32)	19000000124
M50x1.5	31-38	50	57	12	UTL-WNA-M50(D31-38)	19000000125
M63x1.5	37-44	63	65	12	UTL-WNA-M63(D37-44)	19000000126

# Cable glands

## 电缆接头

### 普通塑料防水电缆接头 Plastic cable gland

材料: 尼龙	Material: Nylon
密封件: 丁晴橡胶	Sealing: NBR
防护等级: IP68(要使用O型圈的情况下)	Degree of protection: IP68(with O-sealing)
温度范围: 静态: -40°C...+100°C	Temperature range: Stat: -40°C...+100°C
动态: -20°C...+80°C	Dyn: -20°C...+80°C

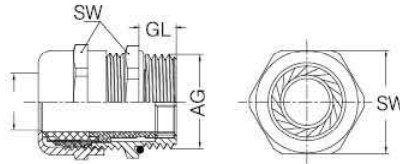

单位: mm  
Unit: mm

螺纹尺寸 Thread size	卡口范围(Φ) Clamping range(Φ)	螺纹外径(AG) Thread diameter (AG)	扳手尺寸(SW) Wrench size (SW)	螺纹长度(GL) Thread length (GL)	型号(灰色) Designation (Grey)	型号 Designation	型号(黑色) Designation (Black)	订货号 Order NO.
<b>PG制螺纹</b> PG Thread								
PG7	3-6.5	12.5	15	8.5	UTL-WNAP-PG7G	09000000210	WNAP-PG7B	09000000220
PG9	4-8	15.2	19	8.0	UTL-WNAP-PG9G	09000000211	WNAP-PG9B	09000000221
PG11	5-10	18.6	22	8.0	UTL-WNAP-PG11G	09000000212	WNAP-PG11B	09000000222
PG13.5	6-12	20.4	24	10	UTL-WNAP-PG13.5G	09000000213	WNAP-PG13.5B	09000000223
PG16	8-14	22.5	27	10	UTL-WNAP-PG16G	09000000214	WNAP-PG16B	09000000224
PG21	13-18	28.3	33	11	UTL-WNAP-PG21G	09000000215	WNAP-PG21B	09000000225
PG29	18-25	37.0	42	11	UTL-WNAP-PG29G	09000000216	WNAP-PG29B	09000000226
PG36	22-32	47.0	52	13	UTL-WNAP-PG36G	09000000217	WNAP-PG36B	09000000227
PG42	31-38	54.0	60	15	UTL-WNAP-PG42G	09000000218	WNAP-PG42B	09000000228
PG48	37-44	59.3	65	14.0	UTL-WNAP-PG48G	09000000219	WNAP-PG48B	09000000229
<b>M 公制螺纹</b> Metric Thread								
M12x1.5	3-6.5	12	15	8	UTL-WNAP-M12G	19000000210	WNAP-M12B	19000000220
M16x1.5	4-8	16	19	8	UTL-WNAP-M16G	19000000211	WNAP-M16B	19000000221
M20x1.5	5-10	20	24	9	UTL-WNAP-M20G	19000000212	WNAP-M20B	19000000222
M20x1.5	6-12	20	24	9	UTL-WNAP-M20G(D6-12)	19000000213	WNAP-M20B(D6-12)	19000000223
M22x1.5	8-14	22	27	10	UTL-WNAP-M22G	19000000214	WNAP-M22B	19000000224
M25x1.5	13-18	25	33	11	UTL-WNAP-M25G	19000000215	WNAP-M25B	19000000225
M32x1.5	18-25	32	42	11	UTL-WNAP-M32G	19000000216	WNAP-M32B	19000000226
M40x1.5	22-32	40	51	13	UTL-WNAP-M40G	19000000217	WNAP-M40B	19000000227
M50x1.5	31-38	50	60	13	UTL-WNAP-M50G	19000000218	WNAP-M50B	19000000228
M63x1.5	37-44	63	65	14	UTL-WNAP-M63G	19000000219	WNAP-M63B	19000000229

# Cable glands

## 电缆接头

### 双锁紧型金属电缆接头 Gland with external strain relief via calmping jaws

材料：黄铜镀镍(外壳)，尼龙PA66(芯套)

Material: Nickel-plate brass, Nylon

防护等级：IP68(要使用O型圈的情况下)

Degree of protection: IP68(with O-sealing)

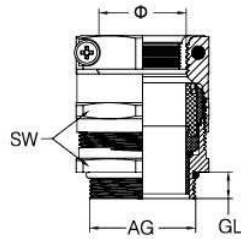

单位：mm  
Unit: mm

螺纹尺寸 Thread size	卡口范围(Φ) Clamping range(Φ)	螺纹外径(AG) Thread diameter(AG)	扳手尺寸(SW) Wrench size(SW)	螺纹长度(GL) Thread length(GL)	型号 Designation	订货号 Order NO.
PG制螺纹 PG Thread						
PG9	4-8	15.2	17	7	UTL-WNKS-PG9(4-8)	0900000310
PG11	5-10	18.6	22	7	UTL-WNKS-PG11(5-10)	0900000311
PG13.5	6-12	20.4	22	8	UTL-WNKS-PG13.5(6-12)	0900000312
PG16	10-14	22.5	24	7.5	UTL-WNKS-PG16(10-14)	0900000313
PG21	13-18	28.3	30	8	UTL-WNKS-PG21(13-18)	0900000314
PG29	18-25	37.0	40	9	UTL-WNKS-PG29(18-25)	0900000315
PG36	22-32	47.0	50	12	UTL-WNKS-PG36(22-32)	0900000316
PG42	30-38	54.0	57	12	UTL-WNKS-PG42(30-38)	0900000317
M 公制螺纹 Metric Thread						
M16x1.5	4-8	16	18	6.5	UTL-WNKS-M16(4-8)	1900000310
M16x1.5	5-10	16	22	6	UTL-WNKS-M16(5-10)	1900000311
M20x1.5	6-12	20	22	7.5	UTL-WNKS-M20(6-12)	1900000312
M25x1.5	10-16	25	27	8	UTL-WNKS-M25(10-16)	1900000313
M25x1.5	13-18	25	30	7.5	UTL-WNKS-M25(13-18)	1900000314
M32x1.5	16-22	32	35	8.5	UTL-WNKS-M32(16-22)	1900000315
M32x1.5	18-25	32	40	8	UTL-WNKS-M32(18-25)	1900000316
M40x1.5	22-30	40	45	12	UTL-WNKS-M40(22-30)	1900000317
M40x1.5	22-32	40	50	12	UTL-WNKS-M40(22-32)	1900000318
M50x1.5	30-38	50	57	12	UTL-WNKS-M50(30-38)	1900000319



# Cable glands

## 电缆接头

### 普通兼容金属防水接头 EMC Cable gland

材料：黄铜镀镍	Material : Nickel-plate brass
密封件：尼龙66和丁晴橡胶	Sealing: Nylon and NBR
防护等级：IP68(要使用O型圈的情况下)	Degree of protection: IP68(with O-sealing)
温度范围：-40℃...+100℃,短时间可以达到120℃	Temperature range: -40℃...+100℃,short-term 120℃

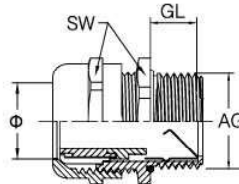

单位：mm  
Unit: mm

螺纹尺寸 Thread size	卡口范围(Φ) Clamping range(Φ)	螺纹外径(AG) Thread diameter(AG)	扳手尺寸(SW) Wrench size(SW)	螺纹长度(GL) Thread length(GL)	型号 Designation	订货号 Order NO.
<b>PG制螺纹</b> PG Thread						
PG7	3-6.5	12.5	14	5	UTL-WNAC-PG7(D3-6.5)	09000000410
PG9	4-8	15.2	18	6	UTL-WNAC-PG9(D4-8)	09000000411
PG11	5-10	18.6	20	6	UTL-WNAC-PG11(D5-10)	09000000412
PG13.5	6-12	20.4	24	7	UTL-WNAC-PG13.5(D6-12)	09000000413
PG16	8-14	22.5	24	7	UTL-WNAC-PG16(D8-14)	09000000414
PG21	13-18	28.3	30	8	UTL-WNAC-PG21(D13-18)	09000000415
PG29	18-25	37.0	40	8	UTL-WNAC-PG29(D18-25)	09000000416
PG36	22-32	47.0	50	9	UTL-WNAC-PG36(D22-32)	09000000417
PG42	30-38	54.0	57	9	UTL-WNAC-PG42(D30-38)	09000000418
<b>M 公制螺纹</b> Metric Thread						
M12x1.5	3-6.5	12	14	5	UTL-WNAC-M12(D3-6.5)	19000000410
M16x1.5	4-8	16	20	6	UTL-WNAC-M16(D4-8)	19000000411
M18x1.5	5-10	18	20	6	UTL-WNAC-M18(D5-10)	19000000412
M20x1.5	6-12	20	24	7	UTL-WNAC-M20(D6-12)	19000000413
M24x1.5	8-14	24	27	7	UTL-WNAC-M24(D8-14)	19000000414
M25x1.5	10-16	25	27	12	UTL-WNAC-M25(D10-16)	19000000415
M25x1.5	13-18	25	30	13	UTL-WNAC-M25(D13-18)	19000000416
M30x1.5	13-18	30	35	8	UTL-WNAC-M30(D13-18)	19000000417
M32x1.5	15-22	32	40	13	UTL-WNAC-M32(D15-22)	19000000418
M32x1.5	18-25	32	40	13	UTL-WNAC-M32(D18-25)	19000000419
M36x1.5	18-25	36	40	8	UTL-WNAC-M36(D18-25)	19000000420
M40x1.5	21-30	40	45	9	UTL-WNAC-M40(D21-30)	19000000421
M40x1.5	22-32	40	50	9	UTL-WNAC-M40(D22-32)	19000000422
M48x1.5	22-32	48	50	9	UTL-WNAC-M48(D22-32)	19000000423
M50x1.5	30-38	50	57	9	UTL-WNAC-M50(D30-38)	19000000424
M56x1.5	30-38	56	57	9	UTL-WNAC-M56(D30-38)	19000000425
M63x1.5	37-44	63	65	10	UTL-WNAC-M63(D37-44)	19000000426

# Cable glands

## 电缆接头

### 多芯金属防水电缆接头 Metal cable gland with multi core

材料：黄铜镀镍

Material : Nickel-plate brass

密封件：尼龙66和丁晴橡胶

Sealing: Nylon and NBR

防护等级：IP65

Degree of protection: IP65

温度范围：-40°C...+100°C,短时间可以达到120°C

Temperature range: -40°C...+100°C,short-term120°C

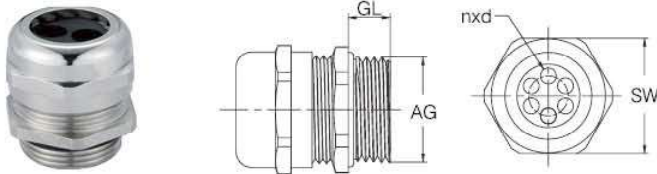

单位：mm  
Unit: mm

螺纹尺寸 Thread size	卡口范围(nxd) Clamping range(nxd)	螺纹外径(AG) Thread diameter(AG)	扳手尺寸(SW) Wrench size(SW)	螺纹长度(GL) Thread lengthGL	型号 Designation	订货号 Order NO.
<b>PG制螺纹</b> PG Thread						
PG9	2x3	15.2	17	6.7	UTL-WNAM-PG9/(2x3)	09000000510
PG21	4x6	28.3	30	8	UTL-WNAM-PG21/(4x6)	09000000511
PG21	3x7	28.3	30	8	UTL-WNAM-PG21/(3x7)	09000000512
PG21	2x6	28.3	30	8	UTL-WNAM-PG21/(2x6)	09000000513
PG21	2x7	28.3	30	8	UTL-WNAM-PG21/(2x7)	09000000514
PG21	2x8	28.3	30	8	UTL-WNAM-PG21/(2x8)	09000000515
PG29	4x9	37	40	9	UTL-WNAM-PG29/(4x9)	09000000516
PG36	5x9	47	50	12	UTL-WNAM-PG36/(5x9)	09000000517
<b>M 公制螺纹</b> Metric Thread						
M16x1.5	2x3	16	17	6.5	UTL-WNAM-M16/(2x3)	19000000510
M20x1.5	6x3	20	22	8	UTL-WNAM-M20/(6x3)	19000000511
M20x1.5	2x5	20	22	8	UTL-WNAM-M20/(2x5)	19000000512
M25x1.5	2x7	25	30	7.5	UTL-WNAM-M25/(2x7)	19000000513
M25x1.5	4x6	25	30	7.5	UTL-WNAM-M25/(4x6)	19000000514
M25x1.5	3x7	25	30	7.5	UTL-WNAM-M25/(3x7)	19000000515
M25x1.5	2x8	33	30	7.5	UTL-WNAM-M25/(2x8)	19000000516
M32x1.5	4x9	32	40	8	UTL-WNAM-M32/(4x9)	19000000517
M40x1.5	5x9	40	50	12	UTL-WNAM-M40/(5x9)	19000000518
M40x1.5	2x15	40	50	12	UTL-WNAM-M40/(2x15)	19000000519

# Cable glands

## 电缆接头

### 外螺纹金属软管接头 Outer thread tube connector

材料：锌合金镀锌或镀铬

Material: Zinc alloy, Zinc plated or Chromium plated

密封件：一端连接软管，另一端由螺纹连接箱体或设备，

Specialty: one end is connector to flexible tube, the other thread end

具有结构紧凑，耐腐蚀等特点

connected to switch chest or equipment, the structure is compact, the surface is a nirothen

应用场合：电机、电缆桥架、电气工程安装、电控箱等

Applications: Electromotor、Cable bridge frame、Electric engineering、Electric control etc.

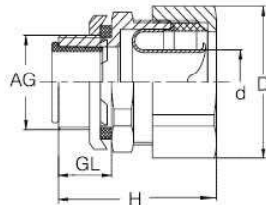

单位：mm  
Unit: mm

螺纹尺寸 Thread size	配用软管(d) Fits to tubing size(d)	螺纹长度(GL) Thread length(GL)	外圆直径(D) External diameter(D)	高度(GL) Height(GL)	型号 Designation	订货号 Order NO.
PG制螺纹 PG Thread						
PG9	10	8.5	26	30	UTL-WNC-PG9/D10	09000000610
PG11	12	10.5	27.5	32	UTL-WNC-PG11/D12	09000000611
PG13.5	15	11.5	31.5	34	UTL-WNC-PG13.5/D15	09000000612
PG16	15	12.5	32	34	UTL-WNC-PG16/D15	09000000613
PG21	20	13.5	38	37	UTL-WNC-PG21/D20	09000000614
PG29	25	15	45.5	44	UTL-WNC-PG29/D25	09000000615
PG29	32	14	55	52	UTL-WNC-PG29/D32	09000000616
PG36	38	17	62	51	UTL-WNC-PG36/D38	09000000617
PG42	38	17	62	51	UTL-WNC-PG42/D38	09000000618
PG48	51	19	77.5	56	UTL-WNC-PG48/D51	09000000619
M 公制螺纹 Metric Thread						
M16x1.5	8	8	24	28	UTL-WNC-M16/D8	19000000610
M16x1.5	10	8	25.5	30	UTL-WNC-M16/D10	19000000611
M20x1.5	12	10	27.5	32	UTL-WNC-M20/D12	19000000612
M24x1.5	15	11.5	32	34	UTL-WNC-M24/D15	19000000613
M30x2.0	20	13	38	37	UTL-WNC-M30/D20	19000000614
M36x2.0	25	13	45	44	UTL-WNC-M36/D25	19000000615

# Cable glands

## 电缆接头

### 快速软管接头 Quick tube onnector

材料: 尼龙

Material: Nylon 6

温度范围: -40°C...+120°C

Temperature range: -40°C...+120°C

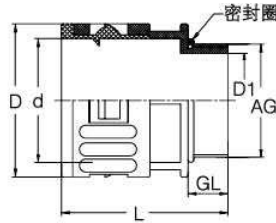

单位: mm  
Unit: mm

螺纹尺寸 Thread size	配用软管(d) Fits to tubing size(d)	螺纹长度(GL) Thread length(GL)	内孔(D1) Bore(D1)	外圆直径(D) External diameter(D)	总长(L) Total length(L)	型号(黑色) Designation(Black)	订货号 Order NO.
<b>PG制螺纹</b> PG Thread							
PG7	AD10.0	9.5	7.5	17.0	34.5	UTL-WNCP-PG7B	09000000710
PG9	AD13.0	9.5	11.5	20.0	34.5	UTL-WNCP-PG9B	09000000711
PG11	AD15.8	9.5	14.0	23.0	36.0	UTL-WNCP-PG11B	09000000712
PG13.5	AD18.5	11.0	16.0	26.0	39.0	UTL-WNCP-PG13.5B	09000000713
PG16	AD21.2	13.0	18.0	29.5	44.0	UTL-WNCP-PG16B	09000000714
PG21	AD28.5	13.0	23.5	37.0	47.0	UTL-WNCP-PG21B	09000000715
PG29	AD34.5	11.5	30.5	43.5	47.0	UTL-WNCP-PG29B	09000000716
PG36	AD42.5	13.5	40.0	51.0	52.0	UTL-WNCP-PG36B	09000000717
<b>M 公制螺纹</b> Metric Thread							
M12x1.5	AD10.0	10.0	8.0	17.0	34.5	UTL-WNCP-M12B	19000000710
M16x1.5	AD13.0	9.5	11.5	20.0	34.5	UTL-WNCP-M16B	19000000711
M18x1.5	AD15.8	9.5	14.0	23.0	36.0	UTL-WNCP-M18B	19000000712
M20x1.5	AD18.5	11.0	16.0	26.0	39.0	UTL-WNCP-M20B/AD18.5	19000000713
M20x1.5	AD21.2	13.0	15.0	29.5	44.0	UTL-WNCP-M20B/AD21.2	19000000714
M25x1.5	AD21.2	13.0	18.0	29.5	44.5	UTL-WNCP-M25B	19000000715
M25x1.5	AD28.5	13.0	20.5	37.0	47.0	UTL-WNCP-M25B/AD28.5	19000000716
M32x1.5	AD28.5	13.0	24.0	37.0	47.0	UTL-WNCP-M32B	19000000717
M40x1.5	AD34.5	11.0	30.0	43.5	48.0	UTL-WNCP-M40B	19000000718
M40x1.5	AD42.5	13.5	33.5	51.0	52.0	UTL-WNCP-M40B/AD42.5	19000000719
M50x1.5	AD54.5	13.5	42.5	63.5	53.5	UTL-WNCP-M50B/AD54.5	19000000720
M63x1.5	AD54.5	14.0	55.0	63.5	53.5	UTL-WNCP-M63B	19000000721

# Cable glands

## 电缆接头

### 塑料蒙盖 Nylon plug

材料：尼龙

Material : Nylon 6

温度范围：-40°C...+120°C

Temperature range: -40°C...+120°C

防护等级：IP68(在使用O型圈的情况下)

Degree of protection: IP68(with O-searing)

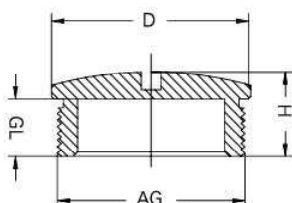

单位：mm  
Unit: mm

螺纹尺寸 Thread size	螺纹长度(GL) Thread length(GL)	高度(H) Height(H)	螺纹外径(AG) Thread diameter(AG)	外圆直径(D) External dimension(D)	型号(灰白色) Designation(Grey)	订货号 Order NO.
<b>PG制螺纹</b> PG Thread						
PG7	6.0	10.0	12.5	15.5	UTL-WNPP-PG7G/R	09000000810
PG9	6.0	10.0	15.2	18.5	UTL-WNPP-PG9G/R	09000000811
PG11	8.0	11.5	18.6	22.0	UTL-WNPP-PG11G/R	09000000812
PG13.5	8.0	11.5	20.4	24.0	UTL-WNPP-PG13.5G/R	09000000813
PG16	8.0	12.0	22.5	27.0	UTL-WNPP-PG16G/R	09000000814
PG21	7.5	12.0	28.3	33.0	UTL-WNPP-PG21G/R	09000000815
PG29	8.0	12.0	37.0	43.0	UTL-WNPP-PG29G/R	09000000816
PG36	10.5	14.0	47.0	55.0	UTL-WNPP-PG36G/R	09000000817
PG42	11.0	15.5	54.0	62.0	UTL-WNPP-PG42G/R	09000000818
PG48	13.0	17.0	59.3	68.5	UTL-WNPP-PG48G/R	09000000819
<b>M 公制螺纹</b> Metric Thread						
M12x1.5	6.0	10.0	12.0	15.0	UTL-WNPP-M12G/R	19000000810
M16x1.5	5.5	10.0	16.0	18.5	UTL-WNPP-M16G/R	19000000811
M20x1.5	8.0	11.5	20.0	25.0	UTL-WNPP-M20G/R	19000000812
M25x1.5	7.5	12.5	25.0	29.5	UTL-WNPP-M25G/R	19000000813
M32x1.5	9.0	13.5	32.0	39.0	UTL-WNPP-M32G/R	19000000814
M40x1.5	11.0	15.0	40.0	48.0	UTL-WNPP-M40G/R	19000000815
M50x1.5	12.0	18.0	50.0	61.5	UTL-WNPP-M50G/R	19000000816
M63x1.5	12.5	18.0	63.0	70.5	UTL-WNPP-M63G/R	19000000817

# Cable glands 电缆接头

## 金属盖 Metal plug

材料:黄铜镀镍

Material: Nickel-plate brass

温度范围: -40°C...+120°C

Temperature range: -40°C...+120°C

防护等级: IP68(在使用O型圈的情况下)

Degree of protection: IP68(with O-searing)

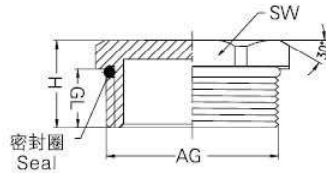

单位: mm  
Unit: mm

螺纹尺寸 Thread size	螺纹长度(GL) Thread length(GL)	高度(H) Height(H)	螺纹外径(AG) Thread diameter(AG)	扳手尺寸(SW) Wrench size(SW)	型号(黑色) Designation(Black)	订货号 Order NO.
<b>PG制螺纹 PG Thread</b>						
PG7	5	8	12.5	14	UTL-WNP-PG7	09000000910
PG9	6	9	15.2	18	UTL-WNP-PG9	09000000911
PG11	6	10	18.6	20	UTL-WNP-PG11	09000000912
PG13.5	7	10	20.4	22	UTL-WNP-PG13.5	09000000913
PG16	7	10	22.5	24	UTL-WNP-PG16	09000000914
PG21	7	11	28.3	30	UTL-WNP-PG21	09000000915
PG29	8	13	37.0	40	UTL-WNP-PG29	09000000916
PG36	8	13	47.0	50	UTL-WNP-PG36	09000000917
PG42	9	15	54.0	55	UTL-WNP-PG42	09000000918
PG48	10	17	59.3	65	UTL-WNP-PG48	09000000919
<b>M 公制螺纹 Metric Thread</b>						
M12x1.5	5	8	12	14	UTL-WNP-M12	19000000910
M16x1.5	6	9	16	18	UTL-WNP-M16	19000000911
M18x1.5	6	10	18	20	UTL-WNP-M18	19000000912
M20x1.5	6	9.5	20	22	UTL-WNP-M20	19000000913
M22x1.5	7	10	22	24	UTL-WNP-M22	19000000914
M24x1.5	7	11	24	27	UTL-WNP-M24	19000000915
M25x1.5	7	11	25	27	UTL-WNP-M25	19000000916
M32x1.5	7	11	32	35	UTL-WNP-M32	19000000917
M36x1.5	8	12	36	40	UTL-WNP-M36	19000000918
M40x1.5	8	13	40	45	UTL-WNP-M40	19000000919
M48x1.5	9	15	48	50	UTL-WNP-M48	19000000920
M50x1.5	9	13	50	55	UTL-WNP-M50	19000000921
M63x1.5	10	17	63	70	UTL-WNP-M63	19000000922

# Cable glands 电缆接头

## 金属扩径环 Metal enlargement

材料：黄铜镀镍

Material : Nickel-plate brass

形状：圆形，六角

Shape: Round, Hexagonal

使用场合：适用于需要装螺纹直径扩大的场合

Applications: Apply to the situation of the diameter need to be reduced

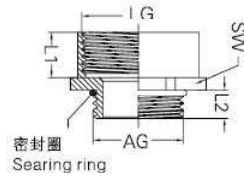

六角金属扩径环  
Hexagonal metal enlargement

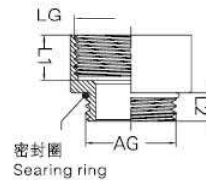

圆形金属扩径环  
Round metal enlargement

单位：mm  
Unit: mm

外螺纹(AG) Outside thread (AG)	内螺纹(LG) Inside thread(LG)	外螺纹长度(L1) Outsidethread length(L1)	内螺纹长度(L2) Insidethread length(L2)	扳手尺寸(SW) Wrench size (SW)	型号(六角) Designation (Hexagonal)	订货号 Order NO.	型号(圆形) Designation (Round)	订货号 Order NO.
PG制螺纹 PG Thread		六角/圆形 Round/Hexagonal	六角/圆形 Round/Hexagonal	六角 Hexagonal				
PG7	PG9	5.0/5.0	8.0/10.0	17	WNSC-PG7PG9	09000001010	UTL-WNSC-PG7GPG9R	09000001019
PG9	PG11	6.0/6.0	10.0/12.0	20	WNSC-PG9PG11	09000001011	UTL-WNSC-PG9GPG11R	09000001020
PG11	PG13.5	6.0/6.0	10.0/12.0	22	WNSC-PG11PG13.5	09000001012	UTL-WNSC-PG11GPG13.5R	09000001021
PG13.5	PG16	6.5/6.5	11.0/13.0	24	WNSC-PG13.5PG16	09000001013	UTL-WNSC-PG13.5GPG16R	09000001022
PG16	PG21	6.5/6.5	12.0/14.0	30	WNSC-PG16PG21	09000001014	UTL-WNSC-PG16GPG21R	09000001023
PG21	PG29	8.0/7.0	13.5/15.0	40	WNSC-PG21PG29	09000001015	UTL-WNSC-PG21GPG29R	09000001024
PG29	PG36	8.0/8.0	15.5/17.0	50	WNSC-PG29PG36	09000001016	UTL-WNSC-PG29GPG36R	09000001025
PG36	PG42	9.0/9.0	14.5/16.0	57	WNSC-PG36PG42	09000001017	UTL-WNSC-PG36GPG42R	09000001026
PG42	PG48	10.0/10.0	14.5/16.0	65	WNSC-PG42PG48	09000001018	UTL-WNSC-PG42GPG48R	09000001027
M 公制螺纹 Metric Thread								
M12x1.5	M16x1.5	5.0/5.0	8.0/10.0	18	WNSC-M12M16	19000001010	UTL-WNSC-M12M16R	19000001017
M16x1.5	M20x1.5	6.0/6.0	10.0/12.0	22	WNSC-M16M20	19000001011	UTL-WNSC-M16M20R	19000001018
M20x1.5	M25x1.5	8.0/6.5	13.5/11.0	27	WNSC-M20M25	19000001012	UTL-WNSC-M20M25R	19000001019
M25x1.5	M32x2.0	7.5/6.5	13.5/12.0	35	WNSC-M25M32	19000001013	UTL-WNSC-M25M32R	19000001020
M32x1.5	M40x2.0	10.0/7.0	13.5/15.0	45	WNSC-M32M40	19000001014	UTL-WNSC-M32M40R	19000001021
M40x1.5	M50x2.0	10.0/9.0	14.5/18.0	55	WNSC-M40M50	19000001015	UTL-WNSC-M40M50R	19000001022
M50x1.5	M63x2.0	9.0/9.0	14.5/16.0	65	WNSC-M50M63	19000001016	UTL-WNSC-M50M63R	19000001023

# Cable glands 电缆接头

## 尼龙扩径环 Polyamide enlargement

材料: 尼龙

Material: Polyamide

颜色: 灰白色、黑色

Color: Grey, Black

温度范围: -40°C...+100°C

Temperature range: -40°C...+100°C

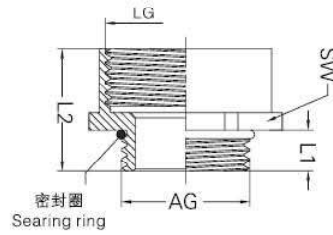

单位: mm  
Unit: mm

外螺纹(AG) Outside thread (AG)	内螺纹(LG) Insidethread(LG)	外螺纹长度(L1) Outsidethread length(L1)	总长度(L2) Total length(L2)	扳手尺寸(SW) Wrench size(SW)	型号 Designation	订货号 Order NO.
PG制螺纹 PG Thread						
PG7	PG9	8	20	19	UTL-WNSCP-PG7PG9	09000001110
PG9	PG11	10	24	22	UTL-WNSCP-PG9PG11	09000001111
PG11	PG13.5	8	23	24	UTL-WNSCP-PG11PG13.5	09000001112
PG13.5	PG16	8	25	27	UTL-WNSCP-PG13.5PG16	09000001113
PG16	PG21	10	27	30	UTL-WNSCP-PG16PG21	09000001114
PG21	PG29	11	32	42	UTL-WNSCP-PG21PG29	09000001115
PG29	PG36	11	35	52	UTL-WNSCP-PG29PG36	09000001116
PG36	PG42	13	42	60	UTL-WNSCP-PG36PG42	09000001117
PG42	PG48	15	65	65	UTL-WNSCP-PG42PG48	09000001118
M 公制螺纹 Metric Thread						
M12x1.5	M16x1.5	8	22	20	UTL-WNSCP-M12M16	19000001110
M16x1.5	M20x1.5	10	27	27	UTL-WNSCP-M16M20	19000001111
M20x1.5	M25x1.5	8	25	30	UTL-WNSCP-M20M25	19000001112
M25x1.5	M32x1.5	11	30	36	UTL-WNSCP-M25M32	19000001113
M32x1.5	M40x1.5	15	34	45	UTL-WNSCP-M32M40	19000001114
M40x1.5	M50x1.5	13	37	55	UTL-WNSCP-M40M50	19000001115



# Cable glands 电缆接头

## 金属减径环 Metal reducer

材料：黄铜镀镍

Material: Nickel-plate brass

形状：六角

Shape: Round, Hexagonal

使用场合：适用于需要装螺纹直径减小的场合

Applications: Apply to the situation of the diameter need to be reduced

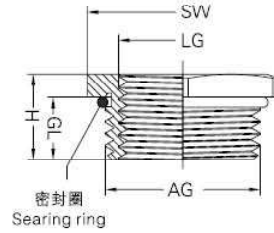

单位：mm  
Unit: mm

外螺纹(AG) Outside thread (AG)	内螺纹(LG) Insidethread(LG)	外螺纹长度(L1) Outsidethread length(L1)	总长(H) Total length(H)	扳手尺寸(SW) Wrench size(SW)	型号(六角) Designation (Hexagonal)	订货号 Order NO.
PG制螺纹 PG Thread						
PG9	PG7	6.0	9	17	UTL-WNSC-PG9PG7	09000001210
PG11	PG9	7.0	11	20	UTL-WNSC-PG11PG9	09000001211
PG13.5	PG11	7.0	10	22	UTL-WNSC-PG13.5PG11	09000001213
PG16	PG13.5	7.0	11	24	UTL-WNSC-PG16PG13.5	09000001214
PG21	PG16	7.0	11	30	UTL-WNSC-PG21PG16	09000001215
PG29	PG21	8.0	13	40	UTL-WNSC-PG29PG21	09000001216
PG36	PG29	9.0	13	50	UTL-WNSC-PG36PG29	09000001217
PG42	PG36	9.0	15	57	UTL-WNSC-PG42PG36	09000001218
PG48	PG42	10.0	15	65	UTL-WNSC-PG48PG42	09000001219
M 公制螺纹 Metric Thread						
M16x1.5	M12x1.5	6.0	9	17	UTL-WNSC-M16M12	19000001210
M20x1.5	M16x1.5	7.0	10	22	UTL-WNSC-M20M16	19000001211
M25x1.5	M20x1.5	7.0	10	27	UTL-WNSC-M25M20	19000001212
M32x2.0	M25x1.5	8.0	11.5	35	UTL-WNSC-M32M25	19000001213
M40x2.0	M32x2.0	9.0	13	42	UTL-WNSC-M40M32	19000001214
M50x2.0	M40x2.0	9.0	14	57	UTL-WNSC-M50M40	19000001215
M63x2.0	M50x2.0	11.0	14	65	UTL-WNSC-M63M50	19000001216

# Cable glands 电缆接头

## 尼龙扩径环 Polyamide enlargement

材料: 尼龙66

Material : Polyamide

颜色: 黑色

Color: Black

温度范围: -40°C...+100°C

Temperature range: -40°C...+100°C

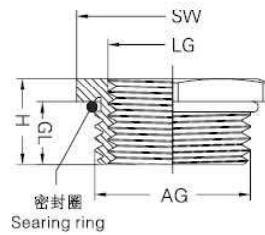

单位: mm  
Unit: mm

外螺纹(AG) Outside thread (AG)	内螺纹(LG) Insidethread(LG)	外螺纹长度(GL) Outsidethread length(GL)	总长(H) Total length(H)	扳手尺寸(SW) Wrench size(SW)	型号 Designation	订货号 Order NO.
PG制螺纹 PG Thread						
PG11	PG9	8	15	24	UTL-WNSCP-PG11PG9	09000001310
PG13.5	PG11	9	21.5	22	UTL-WNSCP-PG13.5PG11	09000001311
PG16	PG11	10	16	27	UTL-WNSCP-PG16PG11	09000001312
PG16	PG13.5	10	17	27	UTL-WNSCP-PG16PG13.5	09000001313
PG21	PG16	11	17	39	UTL-WNSCP-PG21PG16	09000001314
PG29	PG21	11.5	17	39	UTL-WNSCP-PG29PG21	09000001315
M 公制螺纹 Metric Thread						
M20x1.5	M16x1.5	9.5	15	24	UTL-WNSCP-M20M16	19000001310
M25x1.5	M20x1.5	10	17	27	UTL-WNSCP-M25M20	19000001311
M32x1.5	M20x1.5	11.5	17	39	UTL-WNSCP-M32M20	19000001312
M32x1.5	M25x1.5	11	17	39	UTL-WNSCP-M32M25	19000001313
M40x1.5	M32x1.5	11	17	45	UTL-WNSCP-M40M32	19000001314

# Cable glands

## 电缆接头

### 金属螺母 Metal lock nut

材料：黄铜镀镍

Material: Nickel-plate brass

温度范围：-40°C...+100°C

Temperature range: -40°C...+100°C

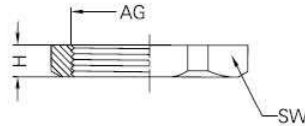

单位：mm  
Unit: mm

螺纹尺寸 Thread size	扳手尺寸(SW) Wrench size(SW)	厚度(H) Thickness(H)	型号 Designation	订货号 Order NO.
PG制螺纹 PG Thread				
PG7	15	2.8	UTL-WNA-PG7/S	09000001410
PG9	18	2.8	UTL-WNA-PG9/S	09000001411
PG11	21	3.0	UTL-WNA-PG11/S	09000001412
PG13.5	22	3.0	UTL-WNA-PG13.5/S	09000001413
PG16	24	3.0	UTL-WNA-PG16/S	09000001414
PG21	30	3.5	UTL-WNA-PG21/S	09000001415
PG29	40	4.0	UTL-WNA-PG29/S	09000001416
PG36	50	4.5	UTL-WNA-PG36/S	09000001417
PG42	57	5.0	UTL-WNA-PG42/S	09000001418
PG48	65	5.5	UTL-WNA-PG48/S	09000001419
M 公制螺纹 Metric Thread				
M12x1.5	15	2.8	UTL-WNA-M12/S	19000001410
M16x1.5	18	2.8	UTL-WNA-M16/S	19000001411
M20x1.5	22	3.0	UTL-WNA-M20/S	19000001412
M25x1.5	27	3.0	UTL-WNA-M25/S	19000001413
M32x2.0	35	3.5	UTL-WNA-M32/S	19000001414
M40x2.0	50	4.5	UTL-WNA-M40/S	19000001415
M50x2.0	57	5.0	UTL-WNA-M50/S	19000001416
M63x2.0	70	5.5	UTL-WNA-M63/S	19000001417

# Cable glands 电缆接头

## 尼龙螺母 Polyamide lock nut

材料: 尼龙66

Material: Polyamide

颜色: 灰色、黑色

Color: Grey, Black

温度范围: -40°C...+100°C

Temperature range: -40°C...+100°C

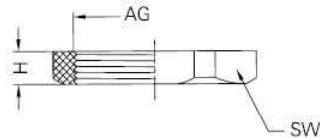

单位: mm  
Unit: mm

螺纹尺寸 Thread size	扳手尺寸(SW) Wrench size(SW)	厚度(H) Thickness(H)	型号(灰色) Designation(Grey)	订货号 Order NO.	型号(黑色) Designation(Black)	订货号 Order NO.
PG制螺纹 PG Thread						
PG7	19	5.0	UTL-WNAP-PG7G/S	09000001510	UTL-WNAP-PG7B/S	09000001520
PG9	22	5.0	UTL-WNAP-PG9G/S	09000001511	UTL-WNAP-PG9B/S	09000001521
PG11	24	5.0	UTL-WNAP-PG11G/S	09000001512	UTL-WNAP-PG11B/S	09000001522
PG13.5	27	6.0	UTL-WNAP-PG13.5G/S	09000001513	UTL-WNAP-PG13.5B/S	09000001523
PG16	30	6.0	UTL-WNAP-PG16G/S	09000001514	UTL-WNAP-PG16B/S	09000001524
PG21	36	7.0	UTL-WNAP-PG21G/S	09000001515	UTL-WNAP-PG21B/S	09000001525
PG29	45	7.0	UTL-WNAP-PG29G/S	09000001516	UTL-WNAP-PG29B/S	09000001526
PG36	59	8.0	UTL-WNAP-PG36G/S	09000001517	UTL-WNAP-PG36B/S	09000001527
PG42	65	8.0	UTL-WNAP-PG42G/S	09000001518	UTL-WNAP-PG42B/S	09000001528
PG48	70	8.0	UTL-WNAP-PG48G/S	09000001519	UTL-WNAP-PG48B/S	09000001529
M 公制螺纹 Metric Thread						
M12x1.5	19	5.0	UTL-WNAP-M12G/S	19000001510	UTL-WNAP-M12B/S	19000001521
M16x1.5	22	5.0	UTL-WNAP-M16G/S	19000001511	UTL-WNAP-M16B/S	19000001522
M18x1.5	24	5.0	UTL-WNAP-M18G/S	19000001512	UTL-WNAP-M18B/S	19000001523
M20x1.5	27	6.0	UTL-WNAP-M20G/S	19000001513	UTL-WNAP-M20B/S	19000001524
M22x1.5	30	6.0	UTL-WNAP-M22G/S	19000001514	UTL-WNAP-M22B/S	19000001525
M24x1.5	30	6.0	UTL-WNAP-M24G/S	19000001515	UTL-WNAP-M24B/S	19000001526
M25x1.5	32	7.0	UTL-WNAP-M25G/S	19000001516	UTL-WNAP-M25B/S	19000001527
M32x1.5	40	7.0	UTL-WNAP-M32G/S	19000001517	UTL-WNAP-M32B/S	19000001528
M40x1.5	49	8.0	UTL-WNAP-M40G/S	19000001518	UTL-WNAP-M40B/S	19000001529
M50x1.5	65	8.0	UTL-WNAP-M50G/S	19000001519	UTL-WNAP-M50B/S	19000001530
M63x1.5	74	8.0	UTL-WNAP-M63G/S	19000001520	UTL-WNAP-M63B/S	19000001531